

By downloading this file to your computer, you are accepting and agreeing to the terms of AWC's end-user license agreement (EULA), which may be viewed here: [End User License Agreement](#). Copyright infringement is a violation of federal law subject to criminal and civil penalties.



EDITION

2024

FDS

FIRE DESIGN SPECIFICATION
for Wood Construction
with Commentary

ANS Approval: September 28, 2023



Updates and Errata

While every precaution has been taken to ensure the accuracy of this document, errors may have occurred during development. Updates or Errata are posted to the American Wood Council website at www.awc.org. Technical inquiries may be addressed to info@awc.org

On behalf of the industry it represents, AWC is committed to ensuring a resilient, safe, and sustainable built environment. To achieve these objectives, AWC contributes to the development of sound public policies, codes, and regulations which allow for the appropriate and responsible manufacture and use of wood products. We support the utilization of wood products by developing and disseminating consensus standards, comprehensive technical guidelines, and tools for wood design and construction, as well as providing education regarding their application.

2024

EDITION

FDS[®]

FIRE DESIGN SPECIFICATION[®]
for Wood Construction
with Commentary



APPROVED
SEPTEMBER 28, 2023



**AMERICAN
WOOD
COUNCIL**

Fire Design Specification (FDS) for Wood Construction 2024 Edition

First Electronic Release: November 3, 2023

ISBN 978-1-940383-55-2

Copyright © 2023 by American Wood Council

All rights reserved. No part of this publication may be reproduced, distributed, or transmitted in any form or by any means, including, without limitation, electronic, optical, or mechanical means (by way of example and not limitation, photocopying, or recording by or in an information storage retrieval system) without express written permission of the American Wood Council.

For information on permission to copy material, please contact:

Copyright Permission
American Wood Council
50 Catoctin Circle, NE, Suite 201
Leesburg, VA 20176
info@awc.org

FOREWORD

This Specification is for use in designing wood buildings. Its use is intended to complement and not supersede any provision of the applicable building code.

Since 2001, the *National Design Specification® for Wood Construction* (NDS®) has contained provisions in Chapter 16 for design of fire-exposed wood members to meet code-required structural fire-resistance ratings based on a standardized ASTM E119 time-temperature exposure. The NDS Chapter 16 provisions apply to exposed timber members of sawn lumber, glued-laminated softwood timber, laminated veneer lumber, parallel strand lumber, laminated strand lumber, and cross-laminated timber. Additional calculation procedures have been developed to address the added fire resistance and thermal benefits of protection using additional wood, gypsum panel products, and some types of insulation. These additional calculation provisions have been developed to provide standardized methods of calculating thermal separation and burn-through requirements as required in ASTM E119 and as provided in AWC's *Technical Report 10: Calculating the Fire Resistance of Exposed and Protected Wood Members* (TR10). The existing design provisions in NDS Chapter 16 and the new protection provisions contained within TR10 have been incorporated in this Specification.

In developing the provisions of this Specification, the most reliable data available from laboratory tests and experience with structures in service have been carefully analyzed and evaluated for the purpose of providing, in convenient form, a national standard of practice. AWC invites and welcomes comments, inquiries, suggestions, and new data relative to the provisions of this document.

It is intended that this Specification be used in conjunction with competent engineering design, accurate fabrication, and adequate supervision of construction. AWC does not assume any responsibility for errors or omissions in the document, nor for engineering designs, plans, or construction prepared from it. Those using this standard assume all liability arising from its use. The design of engineered structures is within the scope of expertise of licensed engineers, architects, or other licensed professionals for applications to a particular structure.

American Wood Council



TABLE OF CONTENTS

1. General Requirements for Fire Design1

1.1 General..... 2

1.2 Terminology..... 2

1.3 Notation..... 6

1.4 Materials Standards..... 6

1.5 Heavy Timber..... 8

1.6 Material Combustibility 10

1.7 Fire-Resistance-Rated Wood Members and Assemblies 11

2. Ignition and Flammability.....13

2.1 General..... 14

2.2 Ignition Resistance 14

2.3 Flame Spread Performance of Wood Products..... 14

2.4 Vertical and Lateral Flame Propagation 15

2.5 Firestopping, Fireblocking and Draftstopping..... 16

3. Fire Resistance19

3.1 General..... 21

3.2 Charring of Wood 22

3.3 Structural Fire Resistance of Exposed Wood Members 23

3.4 Protection of Structural Wood Members and Assemblies 28

3.5 Calculation of Structural Fire Resistance Time of Protected Wood Members and Assemblies 30

3.6 Calculation of Thermal Separation Time 30

3.7 Calculation of Burn-Through Time..... 31

3.8 Tested Fire-Resistance-Rated Assemblies 31

3.9 Component Additive Method for Assemblies 31

3.10 Design of Protected Connections 35

References.....37

Supplements to the Fire Design Specification41

Commentary.....67

List of Figures

Figure 3.1 Char Penetration at Abutting Wood Members that are Unbonded.....23

Figure 3.2 Top of Beam Not Exposed to Fire.....27

Figure 3.3 Top of Beam Exposed to Fire.....27

List of Tables

Table 1.5.1 Minimum Nominal Sizes for Heavy Timber Framing Members.....9

Table 1.5.2 Minimum Sizes for Heavy Timber Roof Decks, Floor Decks and Walls.....9

Table 1.5.3 Topping for Heavy Timber Floor Decks.....9

Table 1.5.4 Heavy Timber Nominal Sizes and Minimum Dimensions 10

Table 2.3.1 Material Classification..... 14

Table 3.3.1.2 Char Depth and Effective Char Depth 24

Table 3.3.1.3 Effective Char Depth 24

Table 3.3.2 Adjustment Factors for Fire Design.....25

Table 3.4.2.1 Fire Resistance Time for Type X Gypsum Panel Products 29

Table 3.4.3.1 Fire Resistance Time for Protected Wood Surfaces.....29

Table 3.9.1.1.1 Structural Fire Resistance Times Assigned to Sawn Lumber or LVL, PSL, or LSL Studs 31

Table 3.9.1.1.2 Structural Fire Resistance Times Assigned to Sawn Lumber or SCL Joists 32

Table 3.9.1.1.3a Structural Fire Resistance Times Assigned to Wood I-Joist Flanges.....33

Table 3.9.1.1.3b Structural Fire Resistance Times Assigned to Wood I-Joist Web 34

Table 3.9.1.2a Added Protection Time Assigned to Wood Membrane.....34

Table 3.9.1.2b Added Protection Time Assigned to Type X Gypsum Panel Membrane 34

Table 3.9.2.2 Added Protection Time Assigned to Insulation Membrane 35



1. GENERAL REQUIREMENTS FOR FIRE DESIGN

1.1	General	2
1.2	Terminology	2
1.3	Notation	6
1.4	Materials Standards	6
1.5	Heavy Timber	8
1.6	Material Combustibility	10
1.7	Fire-Resistance-Rated Wood Members and Assemblies	11

Table 1.5.1	Minimum Nominal Sizes for Heavy Timber Framing Members	9
Table 1.5.2	Minimum Sizes for Heavy Timber Roof Decks, Floor Decks and Walls	9
Table 1.5.3	Topping for Heavy Timber Floor Decks	9
Table 1.5.4	Heavy Timber Nominal Sizes and Minimum Dimensions	10



1.1 General

1.1.1 Scope

Where fire design is required by the applicable building code, this standard establishes fire design provisions for wood construction covered under the ANSI/AWC *National Design Specification (NDS) for Wood Construction*.

1.1.2 Design Methods

Design methods in this standard shall be based on the provisions of this document and the fire exposure

and acceptance criteria specified in the reference standards in each section.

1.1.3 Type of Construction

For the purpose of this Standard, any reference to the Type of Construction is linked to the fire-resistance ratings, materials, and detailing requirements of the applicable building code.

1.2 Terminology

APPROVED. Acceptable to the authority having jurisdiction.

ASSEMBLY. For the purpose of this standard, a system that combines wood structural members and other materials to create portions of buildings such as walls, floors, and roofs.

BURN-THROUGH. The passage of hot gases or flames between or through members or assemblies which are intended to provide thermal separation.

BURN-THROUGH TIME. The period of time before burn-through occurs during an ASTM E119 fire resistance test or as determined using design methods in Chapter 3 which are based on ASTM E119 tests.

COMBUSTIBLE MATERIALS. Materials that ignite and burn when exposed to fire.

CONNECTION. For the purpose of this standard, wood-to-wood, wood-to-metal, or wood-to-concrete connections designed using the *National Design Specification (NDS) for Wood Construction* (see 1.1.1).

CROSS-LAMINATED TIMBER (CLT). A prefabricated engineered wood product consisting of at least three layers of sawn lumber or structural composite lumber where the adjacent layers are cross-oriented and bonded with structural adhesive to form a solid wood panel.

DOUBLE-STUD WALL. Framing method where two stud wall frames are set next to each other on common plates.

DOUBLE WALL. Framing method where two walls are set next to each other.

DRAFTSTOPPING. Material or construction installed to restrict the movement of air and hot gases between concealed spaces within floor-ceiling assemblies and within an attic.

EXTERIOR WALL. A loadbearing or non-loadbearing wall that is used as an enclosing wall for a building, and that has a slope of 60 degrees or greater relative to the horizontal plane, and which has specific requirements for continuity and opening protection.

EXTERIOR WALL COVERING. A material, member, or assembly applied on the exterior side of exterior walls for aesthetics, as a weather-resisting barrier, or as insulation (e.g. cladding, siding, exterior insulation and finish systems, architectural trim and embellishments such as cornices, soffits, facias, gutters and leaders).

FIRE AREA. The aggregate floor area which is used to determine requirements for a fire protection system and which is enclosed and bounded by exterior walls, fire walls, fire barriers, or horizontal assemblies of a building, including areas of the building not provided with surrounding walls that are within the horizontal projection of the adjacent roof or floor above.

FIRE BARRIER. An interior fire-resistance-rated wall that is used to separate interior building areas according to hazards associated with function, for means of egress protection or, for purposes of building compartmentalization into fire areas, and which has specific requirements for continuity and opening protection.

FIRE PARTITION. An interior fire-resistance-rated wall that is used to separate interior spaces according to hazard associated with function, and which has specific requirements for continuity and opening protection.

FIRE PROTECTION SYSTEM. Approved devices, equipment and systems or combinations of systems used to detect a fire, activate an alarm, extinguish, or control a fire; control or manage smoke and products of a fire; or any combination thereof.

FIRE RESISTANCE. The ability of a material, member, or assembly to perform its structural function or to slow or prevent the passage of excessive heat, hot gases, or flames during fire exposure.

FIRE-RESISTANCE-RATED. Having a fire-resistance rating assigned based on ASTM E119 or ANSI/UL 263 fire resistance testing or as determined using design methods in Chapter 3.

FIRE-RESISTANCE RATING (FRR). The period of time a material, member, or assembly performs its structural function and, where required, prevents the passage of excessive heat, hot gases, or flames during an ASTM E119 or ANSI/UL 263 fire resistance test or as determined using design methods in Chapter 3.

FIRE-RETARDANT-TREATED WOOD (FRTW). Wood products that are treated with chemicals to reduce surface-burning characteristics and resist propagation of fire.

FIRE SEPARATION DISTANCE (FSD). The minimum perpendicular distance measured from the building exterior wall to the closer of:

- a. the closest interior lot line; or
- b. the centerline of a street, an alley or public right-of-way; or
- c. an imaginary line between two buildings on the same lot.

FIRE WALL. A fire-resistance-rated wall that is used to provide total separation between adjacent or attached buildings, which extends vertically from the foundation to the roof or beyond, extends horizontally between or beyond exterior walls, and which has specific requirements for opening and penetration protection.

FIREBLOCKING. Material or construction installed to restrict the passage of flames within and between concealed spaces.

FIRESTOPPING. Material, device, or system that is used to prevent the spread of fire for a specified period of time.

- **Fire-resistant joint system.** An assemblage of materials and/or devices that is designed, tested, and approved to resist passage of fire through design joints between fire-resistance-rated assemblies.
- **Membrane-penetration firestop system.** An assemblage of materials and/or devices that is designed, tested, and approved to resist passage of fire through an opening in a membrane of a fire-resistance-rated assembly.
- **Through-penetration firestop system.** An assemblage of materials and/or devices that is designed, tested, and approved to resist passage of fire through an opening in a fire-resistance-rated assembly.

GLUED LUMBER. A product that is manufactured by end-gluing, edge-gluing, or face-gluing pieces of sawn lumber.

GYPSUM PANEL PRODUCTS. A family of sheet products consisting of a noncombustible core primarily of gypsum, includes Glass Mat Gypsum Panel and Gypsum Board. Both product lines are available as fire-rated (Type X).

- **Gypsum board.** A line of sheet products consisting of a noncombustible core primarily of gypsum and manufactured with paper facers. Gypsum board includes gypsum wallboard, gypsum sheathing board, gypsum backing board, exterior gypsum soffit board, gypsum ceiling board, gypsum lath, and gypsum base for veneer plaster.
- **Glass mat gypsum panel.** A gypsum panel product with glass mat facers.
- **Gypsum sheathing.** A gypsum board or glass mat gypsum panel product intended as a backing for exterior surface materials.

HEAVY TIMBER (HT). Wood members or assemblies of wood members of minimum dimensions based on application (see Section 1.5).

HORIZONTAL ASSEMBLY. A fire-resistance-rated floor or roof assembly in which penetrations and openings are restricted or required to be protected.

INTERIOR FINISH. The exposed surfaces of the interior of a room including the surfaces of interior walls, partitions, ceilings and floors.

INTERIOR FLOOR FINISH. The exposed floor surfaces of buildings.

- **Interior floor coverings.** Loose-laid interior floor finish materials, such as carpet and vinyl, that are used to cover floors, including other interior floor finishes.

JOINT. An opening between fire-resistance-rated assemblies designed to allow independent movement of the building in any plane caused by thermal, seismic, wind, or other loading condition.

MECHANICALLY-LAMINATED TIMBER

(MLT). A structural assembly of lumber members set on edge, in contact with adjacent pieces, and attached with mechanical fasteners. Nail-laminated timber (NLT) and mechanically-laminated decking are common types of mechanically-laminated timber.

MEMBER. For the purpose of this standard, an element or interconnected elements used to transfer loads through the structure or to provide support for attached non-structural elements, such as insulation and finish materials. A wood member may consist of one element (e.g., solid beam, column, or panel) or multiple elements (e.g., truss, built-up beam, or built-up column).

MINERAL FIBER INSULATION. Insulation type including fiberglass insulation and mineral wool insulation.

- **Fiberglass insulation (glass wool or fibrous glass).** Insulation composed of synthetic vitreous fibers made by melting predominately silica sand and other inorganic materials, and then physically forming the melted materials into fibers.
- **Mineral wool insulation.** Insulation composed of synthetic vitreous fibers made by melting predominately igneous rock or furnace slag, and other inorganic materials, and then physically forming the melted materials into fibers.

NONCOMBUSTIBLE MATERIALS. Materials that do not ignite or burn when exposed to fire, and composite materials having a core of material(s) that does not ignite or burn when exposed to fire and a finish of combustible material that meets certain performance requirements (e.g., Type X gypsum wallboard).

PARTICLEBOARD. A generic term for a panel primarily composed of cellulosic materials (usually wood), generally in the form of discrete pieces or particles, as distinguished from fibers. The cellulosic

material is combined with synthetic resin or other suitable bonding system by a process in which the interparticle bond is created by the bonding system under heat and pressure.

PLATFORM CONSTRUCTION. Construction where the floor structure is supported by exterior and interior bearing walls below and supports exterior and interior bearing walls above.

PROJECTION. Construction that extends beyond an exterior wall such as cornices, eave overhangs, and exterior balconies.

PROTECTION. Materials used to increase the fire resistance of members, assemblies, and connections.

- **Cover.** A sacrificial layer of a material, such as wood or a gypsum panel product, that is used to protect one or more surfaces of an underlying member and/or connection from direct fire exposure for a specified time (e.g. wood boards or gypsum panel products directly attached to a wood beam).
- **Membrane.** A sacrificial layer typically composed of panels, such as wood structural panels or gypsum panels, that protects an assembly from direct fire exposure for a specified time (e.g. gypsum wallboard ceiling used to protect a floor-ceiling assembly).

SAWN LUMBER. A product that is manufactured from trees by sawing wood logs.

SMOKE BARRIER. A building element such as a wall, floor, ceiling, or other continuous membrane or assembly, either vertical or horizontal, that is designed and constructed to restrict the movement of smoke.

SMOKE PARTITION. A wall assembly that extends from the top of the foundation or floor below to the underside of the floor or roof sheathing, deck, or slab above or to the underside of the ceiling above where the ceiling membrane is constructed to limit the movement of smoke.

STAGGERED-STUD WALL. Framing method that places adjacent studs on opposite sides of wide top and bottom plates to prevent the membranes on each side of the wall from being attached to common studs.

STRUCTURAL COMPOSITE LUMBER (SCL). A group of engineered wood structural products that are bonded with an exterior adhesive. Types of structural composite lumber covered under this designation in this standard are:

- **Laminated veneer lumber (LVL).** A composite of wood veneer sheet elements in which the wood veneer thicknesses does not exceed 0.25" and the wood fiber is primarily oriented along the length of the member.
- **Parallel strand lumber (PSL).** A composite of wood strand elements in which the least dimension of the strands does not exceed 0.25", the average length of the strands is a minimum of 300 times the least dimension, and the wood fibers are primarily oriented along the length of the member.
- **Laminated strand lumber (LSL).** A composite of wood strand elements in which the least dimension of the strands does not exceed 0.10", the average length of the strands is a minimum of 150 times the least dimension, and the wood fibers are primarily oriented along the length of the member.
- **Oriented strand lumber (OSL).** A composite of wood strand elements in which the least dimension of the strands does not exceed 0.10", the average length of the strands is a minimum of 75 times the least dimension, and the wood fibers are primarily oriented along the length of the member.

STRUCTURAL FIRE-RESISTANCE TIME. The period of time a material, member, or assembly performs its structural function during an ASTM E119 or ANSI/UL 263 fire resistance test or as determined using design methods in Chapter 3.

STRUCTURAL GLUED LAMINATED TIMBER (Glulam or GLT). An engineered, stress rated product of a timber laminating plant, comprising assemblies of specially selected and prepared wood laminations bonded together with adhesives. The grain of all laminations is approximately parallel longitudinally. The separate laminations do not exceed 2" in net thickness and are permitted to be composed of:

- One piece
- Pieces joined end-to-end to form any length
- Pieces placed or glued edge-to-edge to make wider ones
- Pieces bent to curved form during gluing

THERMAL SEPARATION TIME. The period of time a material, member, or assembly prevents transmission of excessive heat during an ASTM E119 or ANSI/UL 263 fire resistance test or as determined using design methods in Chapter 3.

TYPE OF CONSTRUCTION (TOC). Classification system used in building codes to establish permitted materials, fire-resistance ratings, and to set detailing requirements for building elements and assemblies.

WOOD I-JOIST (prefabricated wood I-joist). A structural member composed of sawn or structural composite lumber flanges and wood structural panel webs bonded together with exterior exposure adhesives, forming an "I" cross-sectional shape.

WOOD STRUCTURAL PANEL (WSP). A panel manufactured from veneers; or wood strands or wafers; or a combination of veneer and wood strands or wafers; bonded together with waterproof synthetic resins or other suitable bonding systems. Types of wood structural panels covered under this designation in this standard are:

- **Plywood.** A wood structural panel composed of plies of wood veneer arranged in cross-aligned layers. The plies are bonded with an adhesive that cures on application of heat and pressure.
- **Oriented strand board (OSB).** A mat-formed wood structural panel product composed of thin rectangular wood strands or wafers arranged in oriented layers and bonded with waterproof adhesive.
- **Composite panels.** A wood structural panel composed of wood veneer and reconstituted wood-based material bonded together with a waterproof adhesive.

WOOD TRUSS. Engineered frames constructed of wood structural components (and possibly other materials) joined together in triangular shapes using metal connector plates, timber connectors, plywood gussets, or by other means.

1.3 Notation

Except where otherwise noted, the symbols used in this Specification have the following meanings:

C_D	= ASD load duration factor	h_{lam}	= thickness of a CLT lamination where all laminations are of equal thickness, in.
F_b	= reference bending design value, psi	$h_{lam,i}$	= thickness of individual lamination where lamination thicknesses vary, in.
F_{bE}	= critical buckling design value for a bending member, psi	n_{lam}	= number of CLT laminations fully charred
F_c	= reference compression parallel to grain design value, psi	t	= exposure time to standardized time-temperature curve from ASTM E119, hr
F_{cE}	= critical buckling design value for a compression member, psi	t_{gl}	= time for char front to reach glued interface where all laminations are of equal thickness, hr
$F_{c\perp}$	= reference compression perpendicular to grain design value, psi	$t_{gl,i}$	= time for char front to reach glued interface where lamination thicknesses vary, hr
F_t	= reference tension parallel to grain design value, psi	t_p	= protection time (minutes)
F_v	= reference shear design value, psi	W_D	= member or assembly dead load
K_F	= LRFD format conversion factor	W_S	= member or assembly superimposed load for use in ASTM E119 testing or ASD design
a_{char}	= char depth, in.	W_T	= member or assembly total load for use in ASTM E119 testing or ASD design
a_{eff}	= effective char depth, in.	W_{T-LRFD}	= member or assembly total load for strength (LRFD) design
$a_{eff(bearing)}$	= effective char depth for design of bearing perpendicular-to-grain, measured from each exposed edge of the bearing interface, in.	β_t	= non-linear char rate constant, in./hr ^{0.813}
d_p	= thickness of the protective layer of wood, in.	β_n	= nominal char rate constant, in./hr
		λ	= LRFD time effect factor
		ϕ	= LRFD resistance factor

1.4 Materials Standards

The provisions of this standard are not intended to prevent the use of any material or method of construction not specifically prescribed herein, where it is demonstrated by experience, modeling, or testing by an approved agency, that a product or procedure provides equivalent or greater fire safety. Alternative materials and methods shall be subject to approval by the authority having jurisdiction.

1.4.1 Wood Products

Sawn lumber, glued lumber, structural glued laminated timber, prefabricated wood I-joists, structural composite lumber, prefabricated wood trusses, and panel and siding products, shall conform to the applicable standards or grading rules, including marking requirements specified in 1.4.1.1 through 1.4.1.10. Secondary bondlines for structural wood products glued to make larger cross sections shall be made using adhesives that have the heat resistance and

durability that meets the minimum requirements for the material being glued or, alternatively, ANSI 405 *Standard for Adhesives for Use in Structural Glued Laminated Timber*.

1.4.1.1 *Sawn lumber*: Sawn lumber used for load-bearing purposes shall meet the provisions of U.S. Department of Commerce Voluntary Product Standard 20 (PS 20) American Softwood Lumber Standard. Each piece shall be identified by the grademark of a lumber grading or inspection agency accredited by the American Lumber Standards Committee (ASLC). The grademark shall include an easily distinguishable mark or insignia of the accredited agency in accordance with the requirements of PS 20.

1.4.1.2 *Glued lumber*: Glued lumber used for load-bearing purposes shall meet the provisions of PS 20. Each piece shall be identified by the grademark of a lumber grading or inspection agency accredited by

ALSC. The grademark shall include an easily distinguishable mark or insignia of the agency in accordance with the requirements of PS 20 and the *ALSC Glued Lumber Policy*. The grademark shall include an indication that glued joint integrity is subject to quality control by the accredited agency.

1.4.1.2.1 End-jointed (finger-jointed) lumber used in fire-resistance-rated assemblies shall be manufactured with heat-resistant adhesives (HRA) meeting the requirements of the American Lumber Standard Committee *Glued Lumber Policy* or with adhesives complying with ANSI 405 *Standard for Adhesives for Use in Structural Glued Laminated Timber*. The grademark shall include the designation “Heat-Resistant Adhesive” or “HRA” or “Adhesives Meet ANSI 405”.

1.4.1.2.2 Face-glued and edge-glued lumber used in fire-resistance-rated assemblies shall be manufactured with adhesives complying with ANSI 405 *Standard for Adhesives for Use in Structural Glued Laminated Timber*. The grademark shall include the designation “Adhesives Meet ANSI 405.”

1.4.1.3 *Structural glued laminated timber*: Structural glued laminated timber shall meet the provisions of ANSI A190.1 *Structural Glued Laminated Timber*. Each piece shall be identified with the trademark of an accredited inspection agency in accordance with the requirements of ANSI A190.1.

1.4.1.4 *Prefabricated wood I-joists*: Prefabricated wood I-joists shall meet the provisions of ASTM D5055 *Standard Specification for Establishing and Monitoring Structural Capacities of Prefabricated Wood I-Joists*. Each piece shall be identified with the trademark of an accredited inspection agency in accordance with the requirements in ASTM D5055.

1.4.1.5 *Structural composite lumber*: Structural composite lumber used in applications covered by this standard shall meet the provisions of ASTM D5456 *Standard Specification for Evaluation of Structural Composite Lumber Products*. Each piece shall be identified with the trademark of an accredited inspection agency in accordance with the requirements in ASTM D5456.

1.4.1.6 *Prefabricated wood trusses*: Prefabricated wood trusses used in applications covered by this

standard shall meet the provisions set forth in ANSI/TPI 1 *National Design Standard for Metal Plate Connected Wood Truss Construction*, the truss design drawings, or the manufacturer’s code evaluation report.

1.4.1.7 *Plywood*: Plywood shall meet the provisions of U.S. Department of Commerce Voluntary Product Standard 1 (PS 1) *Structural Plywood*, U.S. Department of Commerce Voluntary Product Standard 2 (PS 2) *Performance Standard for Wood Structural Panels*, or applicable code evaluation reports. Each panel shall be identified for grade, bond classification, and Performance Category by the trademarks of an approved testing and grading agency. The Performance Category value shall be used as the “nominal panel thickness” whenever referenced in this standard.

1.4.1.8 *Oriented-strand board (OSB)*: Oriented-Strand Board shall meet the provisions of PS 2 or applicable code evaluation reports. Each panel shall be identified for grade, bond classification, and Performance Category by the trademarks of an approved testing and grading agency. The Performance Category value shall be used as the “nominal panel thickness” whenever referenced in this standard.

1.4.1.9 *Particleboard*: Particleboard shall meet the provisions of ANSI A208.1 *Particleboard Standard* and any additional requirements as set forth in the manufacturer’s code evaluation report.

1.4.1.10 *Cross-laminated timber*: Cross-laminated timber shall meet the requirements of ANSI/APA PRG 320.

1.4.2 Gypsum Panel Products

Gypsum board shall conform to ASTM C1396 *Standard Specification for Gypsum Board*. Glass mat gypsum panels used as an exterior substrate for a weather barrier shall conform to ASTM C1177 *Standard Specification for Glass Mat Gypsum Substrate for Use as Sheathing*. Glass mat gypsum panels not used as an exterior substrate for a weather barrier shall conform to ASTM C1658 *Standard Specification for Glass Mat Gypsum Panels*. Gypsum panel products shall be installed as specified in 1.4.2.1 through 1.4.2.2.

1.4.2.1 *Gypsum panel installation*: Regular and Type X gypsum panel products shall be installed in accordance with the provisions of this standard. Where installation requirements for a specific application are

not provided in this standard, the gypsum panel products shall be installed in accordance with ASTM C840 *Standard Specification for Application and Finishing of Gypsum Board*.

1.4.2.2 *Gypsum sheathing installation*: Regular and Type X gypsum sheathing shall be installed in accordance with the provisions of this standard. Where installation requirements for a specific application are not provided in this standard, the gypsum sheathing shall be installed in accordance with ASTM C1280 *Standard Specification for Application of Exterior Gypsum Panel Products for Use as Sheathing*.

1.4.3 Insulation

Mineral fiber insulation, including fiberglass or mineral wool, shall conform to the standards specified in 1.4.3.1 for batts or blankets and 1.4.3.2 for loose-fill insulation.

1.4.3.1 *Batts or blankets*: Mineral fiber thermal insulation batts or blankets shall meet the provisions of ASTM C665 *Standard Specification for Mineral-Fiber Blanket Thermal Insulation for Light Frame Construction and Manufactured Housing*.

1.4.3.2 *Loose-fill*: Mineral fiber loose-fill thermal insulation shall meet the provisions of ASTM C764 *Standard Specification for Mineral Fiber Loose-Fill Thermal Insulation*.

1.4.4 Fasteners

Fasteners shall conform to the standards specified in 1.4.4.1 through 1.4.4.4.

1.4.4.1 *Bolts*: Bolts shall comply with ANSI/ASME B18.2.1 *Square and Hex Bolts and Screws (Inch Series)*.

1.4.4.2 *Lag screws*: Lag screws or lag bolts shall comply with ANSI/ASME B18.2.1 *Square and Hex Bolts and Screws (Inch Series)*.

1.4.4.3 *Screws*: Wood screws shall comply with ANSI/ASME B18.6.1 *Wood Screws (Inch Series)*. Screws used to attach gypsum panel products shall comply with ASTM C1002 *Standard Specification for Steel Self-Piercing Tapping Screws for Application of Gypsum Panel Products or Metal Plaster Bases to Wood Studs or Steel Studs*.

1.4.4.4 *Nails*: Nails shall comply with ASTM F1667 *Standard Specification for Driven Fasteners: Nails, Spikes, and Staples*.

1.4.5 Metal Parts

Metal parts shall be designed in accordance with the applicable code-recognized design procedures. Connections between wood members and metal parts shall be designed in accordance with the NDS and the appropriate code-referenced standard for metal parts.

1.4.6 Concrete or Masonry Parts

Concrete or masonry parts shall be designed in accordance with the applicable code-recognized design procedures. Connections between wood members and concrete or masonry parts shall be designed in accordance with the NDS and the appropriate code-referenced standard for concrete or masonry.

1.5 Heavy Timber

1.5.1 Heavy Timber Requirements

1.5.1.1 Heavy timber framing members shall consist of sawn lumber, structural glued laminated timber, glued lumber, or structural composite lumber with configurations and minimum sizes as specified in Table 1.5.1 and Table 1.5.4.

1.5.1.2 Heavy timber roof decks, floor decks, and walls shall consist of sawn lumber, structural glued laminated timber, glued lumber, structural composite lumber, wood structural panels, or cross-laminated timber with configurations and minimum sizes as specified in Table 1.5.2 and Table 1.5.4.

1.5.1.3 Heavy timber floor decks constructed of lumber decking or mechanically laminated decking shall be topped with one of the materials listed in Table 1.5.3.

Table 1.5.1 Minimum Nominal Sizes for Heavy Timber Framing Members¹

Building Element	Heavy Timber Framing Member Configurations	Minimum Size
Roof framing	Wood arches from the floor line or grade, not supporting floors: –Lower half of the height	6x8 ¹
	–Upper half of the height	6x6 ¹
	Wood arches from the top of walls, not supporting floors	4x6 ¹
	Wood beams and girders	4x6 ¹
	Wood trusses ²	4x6 ¹
	Wood framing members protected by approved automatic sprinklers under the roof deck	3x6 ¹
Floor framing	Wood beams and girders	6x10 ¹
	Wood arches supporting floors	8x8 ¹
	Wood trusses	8x8 ¹
Columns	Wood columns: –Supporting floor loads	8x8 ¹
	–Supporting only roof and ceiling loads	6x8 ¹

¹ See Table 1.5.4 for minimum dimensions of sawn lumber or glued lumber; structural glued laminated timber; and LSL, LVL, or PSL that correspond to these heavy timber nominal sizes.

² Spaced members shall be permitted, where composed of two or more members that are not less than 3x6. The intervening spaces between the 3-inch (nominal) spaced members shall be either entirely filled with blocking or the spaces shall be tightly enclosed by a continuous wood cover plate of 2-inch (nominal) minimum thickness, attached to the fire-exposed edge(s) of the 3-inch (nominal) spaced members. Splice plates shall be no less than 3x6.

Table 1.5.2 Minimum Sizes for Heavy Timber Roof Decks, Floor Decks and Walls

Building Element	Heavy Timber Panel Configuration	Minimum Size
Roof decks	Wood structural panels	1-1/8 in., nominal thickness ²
	Lumber decking, laid flat and splined or T&G	2x3 ¹
	Mechanically-laminated decking, set on edge and fastened to adjacent pieces	2x3 ¹
	CLT, laid flat and splined, lap-spliced, or T&G	3 in., actual thickness ²
	Floor decks	Lumber decking ³ , laid flat and splined or T&G
Mechanically-laminated decking ³ , set on edge and fastened to adjacent pieces		2x4 ¹
CLT, laid flat and splined, lap-spliced, or T&G		4 in., actual thickness ²
Exterior walls	Mechanically laminated decking, assembled and fastened with wide faces in contact and installed with the length of the wood decking members oriented either vertically or horizontally to form a solid wood wall	2x4 ¹
	CLT	4 in., actual thickness ²
Interior walls and partitions	Wood planks, laid flat and splined or T&G	2 layers 1x4, nominal size
	Mechanically laminated decking, assembled and fastened with wide faces in contact and installed with the length of the wood decking members oriented either vertically or horizontally to form a solid wood wall	2x4 ¹
	CLT	3 in., actual thickness ²

¹ See Table 1.5.4 for minimum dimensions of sawn lumber or glued lumber; structural glued laminated timber; and LSL, LVL, or PSL that correspond to these heavy timber nominal sizes.

² “Thickness” refers to cross-sectional dimension perpendicular to fire-exposed face.

³ Floor decks constructed with lumber decking or mechanically laminated decking shall be topped with one of the topping materials listed in Table 1.5.3.

Table 1.5.3 Topping for Heavy Timber Floor Decks

Topping Material	Minimum Size
Tongue-and-groove wood plank flooring, laid crosswise or diagonally	1x3, nominal size
Wood structural panels	15/32 in., nominal thickness
Particleboard panels	1/2 in., actual thickness
Concrete or gypsum concrete topping	0.75 in. thickness

Table 1.5.4 Heavy Timber Nominal Sizes and Minimum Dimensions

Heavy Timber Nominal Size	Sawn Lumber or Glued Lumber ¹ Minimum Dimensions		Structural Glued-Laminated Timber Minimum Dimensions		LSL, LVL, or PSL Minimum Dimensions	
	Narrow Face (inches)	Wide Face (inches)	Narrow Face (inches)	Wide Face (inches)	Narrow Face (inches)	Wide Face (inches)
Framing Members						
8x8	7-1/4	7-1/4	6-3/4	8-1/4	7	7-1/2
6x10	5-1/2	9-1/4	5	10-1/2	5-1/4	9-1/2
6x8	5-1/2	7-1/4	5	8-1/4	5-1/4	7-1/2
6x6	5-1/2	5-1/2	5	6	5-1/4	5-1/2
4x6	3-1/2	5-1/2	3	6-7/8	3-1/2	5-1/2
3x6	2-1/2	5-1/2	2-1/2	5-1/2	2-1/2	5-1/2
Lumber Decking Members						
3x4	2-1/2	3-1/2	2-1/2	3-1/2	2-1/2	3-1/2
2x4	1-1/2	3-1/2	--	--	1-1/2	3-1/2
2x3	1-1/2	2-1/2	--	--	1-1/2	2-1/2

¹ Glued lumber meeting the requirements of ALSC Glued Lumber Policy.

1.6 Material Combustibility

Use of materials shall be in accordance with this section and the applicable building code requirements for the Type of Construction.

1.6.1 Noncombustible Materials

1.6.1.1 Material required to be noncombustible shall be tested in accordance with ASTM E136 or ASTM E2652 and meet the ASTM E136 requirements to be classified as noncombustible. A material shall not be classified as a noncombustible material if it is subject to an increase in combustibility or flame spread beyond the limitations herein established through the effects of age, moisture, or other atmospheric conditions.

1.6.1.2 Composite material that has a base layer of noncombustible material, as determined in accordance with 1.6.1.1, and a surface layer of not more than 0.125 inches thick that has a flame spread index not greater than 50 as determined in accordance with ASTM E84 or UL 723, shall be acceptable as noncombustible materials.

1.6.1.3 Material not meeting the requirements of 1.6.1.1 or 1.6.1.2 shall be deemed as combustible material and meet the requirements of 1.6.2.

1.6.2 Combustible Materials

1.6.2.1 Where combustible materials are permitted, they shall comply with the requirements in Chapter 2.

1.7 Fire-Resistance-Rated Wood Members and Assemblies

The required fire-resistance ratings for wood members and assemblies shall be in accordance with this section and the applicable building code requirements for the Type of Construction.

1.7.1 Fire-Resistance-Rated Construction

Fire-resistance ratings for wood members and assemblies shall be established in accordance with Chapter 3.

1.7.2 Continuity of Fire-Resistance Rating

The fire-resistance rating of a fire-resistance-rated assembly shall be maintained for the full extent of the assembly, as determined in Chapter 3, according to the continuity requirements of the applicable building code and detailing requirements at intersections in 1.7.8.

1.7.3 Supporting Construction

Construction that supports gravity loads from fire-resistance-rated building elements or assemblies shall have a fire-resistance rating that is equal to or greater than the required fire-resistance rating of the supported building elements or assemblies, except as permitted in this chapter and by the applicable building code.

1.7.3.1 *Platform construction:* In platform construction where a floor-ceiling assembly supports gravity loads from a wall, portions of the floor-ceiling construction that support the wall shall provide at least the same fire-resistance rating as required for the wall. Where a floor-ceiling assembly supports an exterior wall, the material requirements of the floor-ceiling assembly shall be in accordance with requirements for interior building elements for the Type of Construction, including portions of the floor-ceiling construction that support gravity loads from the exterior wall.

1.7.4 Column Protection

Wood columns required to have a fire-resistance rating shall be designed in accordance with Chapter 3.

1.7.4.1 A wood column shall meet its required fire-resistance rating for the entire height of the column without consideration of protection from ceiling membranes.

1.7.4.2 Where a wood column is located within a wall assembly, protection provided to the wall assembly that also protects the column, shall be

permitted to be included in the design of the wood column.

1.7.4.3 Vertical wood members, such as wood columns (including built-up columns) and boundary elements, located entirely within a loadbearing wood stud wall assembly shall be considered to have the fire-resistance rating of the wall assembly without additional protection where the wood member has cross-section dimensions that are equal to or greater than cross-section dimensions of the wood studs.

1.7.5 Beam Protection

Wood beams required to have a fire-resistance rating shall be designed in accordance with Chapter 3.

1.7.5.1 A wood beam shall meet its required fire-resistance rating for the entire span of the beam. For multi-span beams where individual spans have different required fire-resistance ratings, the maximum required fire-resistance rating shall be provided for all spans.

EXCEPTION: For multi-span beams where individual spans have different required fire-resistance ratings, and where failure of any individual span would not decrease the fire-resistance ratings of the remaining spans, the fire-resistance rating required for each individual span shall be provided.

1.7.5.2 Where a wood beam supports gravity loads from more than two floors, more than one floor and one roof, or a wall more than two stories high, the wood beam shall achieve its required fire-resistance rating without consideration of protection from ceiling membranes.

1.7.5.3 Where a wood beam supports gravity loads from two floors or less, one floor and one roof, or walls not more than two stories high, ceiling membranes that also provide protection to the beam shall be permitted to be included in the design of the beam.

1.7.5.4 Horizontal wood members, such as wood beams (including built-up beams), and boundary elements located entirely within a wood joist floor-ceiling or roof-ceiling assembly and that support gravity loads from one floor or one roof only shall be

considered to have the fire-resistance rating of the floor-ceiling or roof-ceiling assembly without additional protection where the wood member has cross-sectional dimensions that are equal to or greater than cross-section dimensions of the wood joists.

1.7.6 Truss Protection

The fire-resistance rating of wood trusses and wood truss assemblies shall be established based on tests or approved calculations that consider the fire performance of the wood trusses, including connections such as chord splices and web-to-chord connections. Approval shall be based on tests or analyses that demonstrate the fire-resistance of the truss or assembly meets the required fire resistance.

1.7.6.1 A wood truss shall meet its required fire-resistance rating for the entire length of the truss.

1.7.6.2 Where a wood truss supports gravity loads from more than two floors, more than one floor and one roof, or a wall more than two stories high, the wood truss shall achieve its required fire-resistance rating without consideration of protection from ceiling membranes.

1.7.6.3 Where a wood truss supports gravity loads from two floors or less, one floor and one roof, or walls not more than two stories high, ceiling membranes that also provide protection to the truss shall be permitted to be included in the design of the truss.

1.7.7 Protection of Connections

Where a wood member is required to have a fire-resistance rating, structural connections of that member shall be protected from fire exposure for the time corresponding to the required fire-resistance rating of the wood member. Protection of the structural connection shall be established by test or designed in accordance with 3.10. Intersections of fire-resistance-rated assemblies shall be in accordance with 1.7.8.

EXCEPTION: Structural connections tested as part of a fire-resistance-rated assembly shall be considered to have the fire-resistance rating of the assembly without additional protection.

1.7.8 Joints and Intersections Between Fire-Resistance-Rated Assemblies

Where required by the applicable building code, intersections of fire-resistance-rated assemblies shall be detailed to prevent burn-through before the required thermal separation time is reached (see Section 3.7).

Where use of a fire-resistant joint system is required at joints between fire-resistance-rated assemblies, the fire-resistant joint system shall be in accordance with Section 2.5.1.3. Where a membrane is used to protect a fire-resistance-rated assembly, the edges of the membrane shall be protected in accordance with 1.7.8.1. Fireblocking shall be installed at intersections of concealed spaces in accordance with 2.5.2.

1.7.8.1 *Edges of membranes:* Edges of membranes shall be detailed to prevent fire from circumventing the membrane protection and compromising the protected assembly. Installation of gypsum panels in accordance with 1.7.8.1.1 and 1.7.8.1.2 shall be deemed to satisfy this requirement.

1.7.8.1.1 Where a gypsum panel ceiling membrane intersects a gypsum panel wall membrane, the gypsum panel ceiling membrane shall be installed prior to the gypsum panel wall membrane to ensure that the gypsum panel ceiling membrane extends past the gypsum panel wall membrane.

1.7.8.1.2 Where a gypsum panel wall membrane intersects at a wall-to-wall intersection, the gypsum panel membrane on the wall with a greater fire-resistance rating shall be installed prior to the gypsum panel membrane on the wall with a lesser fire-resistance rating. For fire-resistance-rated wood-frame walls, the edges of gypsum wall panel membranes at wall-to-wall intersections shall be attached to and fully supported by vertical framing equal in size to the wood studs or larger.

1.7.8.2 *Wood members entering concrete or masonry fire walls:* Where wood structural members are embedded in a concrete or masonry fire wall from opposite sides of the fire wall, there shall be at least 4 inches between the embedded member ends. Where wood members frame into hollow walls or walls of hollow units, the hollow space shall be filled with non-combustible materials that are approved for use as fireblocking and shall fill the full thickness of the wall for a distance not less than 4 inches above, below, and between the embedded ends of members.

1.7.9 Limitations and Protection of Openings

Limitations and protection of openings and penetrations in fire-resistance-rated assemblies shall be in accordance with the applicable building code.

2. IGNITION AND FLAMMABILITY

2.1	General	14
2.2	Ignition Resistance	14
2.3	Flame Spread Performance of Wood Products	14
2.4	Vertical and Lateral Flame Propagation	15
2.5	Firestopping, Fireblocking and Draftstopping	16

Table 2.3.1	Material Classification	14
-------------	-------------------------	----



2.1 General

2.1.1 Scope

Chapter 2 specifies ignition and flammability requirements for wood products used in wood construction and provides reference test standards to be used to show compliance with these requirements.

2.2 Ignition Resistance

Where ignition resistance of combustible exterior wall coverings is regulated, materials shall be tested in accordance with NFPA 268 and shall not exhibit sustained flaming when exposed to an incident radiant heat flux of 12.5 kW/m².

EXCEPTION: Testing is not required for wood or wood-based products used as exterior wall coverings.

2.3 Flame Spread Performance of Wood Products

2.3.1 Interior Wall and Ceiling Finish Materials

2.3.1.1 Where interior wall and ceiling finishes are required to be tested for flame spread and smoke development, materials used in these applications shall be tested in accordance with ASTM E84 or UL723 and shall be classified in accordance with their reported flame spread index (FSI) and smoke developed index (SDI) as indicated by Table 2.3.1.

Table 2.3.1 Material Classification

Class	FSI Range	SDI Range
A	0-25	0-450
B	30-75	0-450
C	80-200	0-450

EXCEPTION: Wood materials tested in accordance with NFPA 286 and complying with the following requirements shall be considered to meet the requirements of Class A:

1. During the 40-kW exposure, flames shall not spread to the ceiling.
2. Flames shall not spread to the outer extremity of the sample on any wall or ceiling.
3. Flashover, as defined in NFPA 286, shall not occur.
4. The peak heat release rate throughout the test shall not exceed 800 kW.
5. The total smoke released throughout the test shall not exceed 1,000 m².

2.3.1.2 As an alternative to 2.3.1.1, the FSI and SDI values and the associated material classifications listed in Supplement A1 shall be permitted to be used for sawn lumber and products manufactured from sawn lumber, such as structural glued laminated timber and cross-laminated timber, of the species tested, and the FSI values and material classifications listed in Supplement A2 shall be permitted to be used for oriented strand board (OSB), hardwood and softwood plywood, particleboard, and medium density fiberboard (MDF) of the listed thicknesses.

2.3.2 Interior Floor Finish Materials

Where interior floor finish are required to be classified for fire performance, these materials shall be tested in accordance with ASTM E648 or NFPA 253 and shall meet the requirements of Class I (0.45 watts/cm² or greater) or Class II (0.22 watts/cm² or greater) in accordance with the applicable building code.

2.3.3 Fire-Retardant-Treated Wood

Fire-retardant-treated wood (FRTW) shall meet the conditions of classification specified in ASTM E2768. FRTW shall be impregnated with chemicals by a pressure process or other means during manufacture. Where FRTW is used in locations that are damp, wet, or exposed to weather, it shall meet the conditions of classification specified in ASTM E2768 after accelerated weathering in accordance with ASTM D2898 and shall be identified and labeled "exterior".

FRTW not labeled “exterior” shall demonstrate a maximum 28% moisture content when tested in accordance with ASTM D3201 at 92% relative humidity.

2.3.3.1 *Design Values:* Design values and treatment adjustment factors for FRTW shall consider both the immediate effects of treatment chemicals and re-drying, and the long-term effects of elevated temperature and humidity on wood properties. Treatment adjustment factors shall consider the wood species and the climatological location where FRTW will be used. All adjustment factors applicable to untreated wood from the NDS shall also apply to FRTW.

2.3.3.1.1 *Softwood Plywood:* Design values for fire-retardant-treated softwood plywood shall be determined based on published design values for untreated softwood plywood determined in accordance with PS 1 or PS 2, with treatment adjustment factors determined and published by the fire-retardant-treatment manufacturer in accordance with ASTM D5516 and ASTM D6305.

2.3.3.1.2 *Sawn Lumber:* Design values for fire-retardant-treated sawn lumber shall be determined based on the design values for untreated sawn lumber published by lumber rules writing agencies

accredited by the American Lumber Standard Committee under PS 20, with treatment adjustment factors determined and published by the fire-retardant-treatment manufacturer in accordance with ASTM D5664 and ASTM D6841.

2.3.3.1.3 *Laminated Veneer Lumber (LVL):* Reference design values and treatment adjustment factors for fire-retardant-treated LVL shall be determined and published by the fire-retardant-treated LVL manufacturer in accordance with ASTM D8223.

2.3.4 Wood-Based Products with Fire-Retardant Coatings

Approved wood-based products with fire-retardant coatings used as interior wall and ceiling finish materials shall be classified in accordance with ASTM E84 or UL723 as required in 2.3.1. Approved wood-based products with fire-retardant coatings used as an alternative to FRTW shall meet the conditions of classification specified in ASTM E2768. A wood-based product with fire-retardant coating shall be used in approved end-use environmental conditions. The effects of fire-retardant coatings on strength and stiffness shall be evaluated in the approval process and accounted for in design.

2.4 Vertical and Lateral Flame Propagation

2.4.1 Exterior Wall Coverings

Where combustible exterior wall coverings are permitted by the Type of Construction and the ignition resistance of the exterior wall covering is regulated, wood or wood-based materials used as wall coverings shall meet the requirements of Sections 2.2, 2.3.3, and this section.

2.4.1.1 *Coverage area:* Exterior wall coverings of wood or wood-based materials shall not exceed 10% of the exterior wall surface when the fire separation distance is 5 feet or less.

EXCEPTION: Where the exterior wall covering is constructed of fire-retardant-treated wood suitable for exterior use, there is no limit of the coverage area.

2.4.1.2 *Coverage height:* Exterior wall coverings of wood or wood-based materials shall not exceed 40 feet in height above grade.

EXCEPTION: Where the exterior wall covering is constructed of fire-retardant-treated wood (FRTW) suitable for exterior use, the exterior wall covering shall not exceed 60 feet in height above grade. Where FRTW exterior wall coverings are used above 40 feet, the exterior wall shall be tested in accordance with and shall comply with the acceptance criteria of NFPA 285.

2.4.1.3 *Fireblocking:* Where exterior wall coverings or other exterior architectural elements are of wood construction or installed over wood furring or wood, fireblocking meeting the requirements of 2.5.2 shall be installed within concealed spaces between the exterior wall coverings and the exterior walls. The

distance between the back of the exterior wall covering and the exterior wall shall not exceed 1-5/8 inches. Fireblocking shall be installed at maximum intervals of 20 feet in either dimension so that there will be no concealed space exceeding 100 square feet between fireblocking. Exterior trim need not be considered as part of the 20-foot interval if the exterior trim sections are separated by at least 4 inches and the ends are closed.

EXCEPTION: Fireblocking shall not be required where the exterior wall covering has been tested without the fireblocking and complies with NFPA 285, and the exterior wall covering is installed as tested.

2.4.1.4 *Top of exterior walls:* Exterior wall coverings of wood or wood-based materials shall not extend beyond the top of exterior walls.

2.4.1.5 *Wood veneers:* Wood veneers used as part of the exterior wall covering shall meet the requirements of this section.

2.4.1.5.1 *Wood veneer thickness:* Wood veneers shall be no less than 1-inch (nominal) lumber (3/4-inch thickness), 7/16-inch exterior hardboard siding, or 3/8-inch exterior-type wood structural panels or particleboard.

2.4.1.5.2 Wood veneer shall be attached to a noncombustible backing or furred from a noncombustible sheathing.

2.4.1.5.3 Where open or spaced wood veneers are installed without concealed spaces, the wood veneers shall not project more than 24 inches from the exterior wall.

2.4.2 Building Projections

Balconies and similar appendages of wood construction, and projections of wood or wood-based materials extending to less than five feet from a property line or a line used to establish fire separation distance, shall be in accordance with the applicable building code.

2.5 Firestopping, Fireblocking and Draftstopping

2.5.1 Firestopping

2.5.1.1 *Membrane-penetration firestop system:* Where an approved membrane-penetration firestop system is required to protect a membrane penetration in a fire-resistance-rated assembly, the assembly shall be permitted to be designed in accordance with Chapter 3, and the firestop system shall have an F and T rating no less than the fire-resistance rating of the fire-resistance-rated assembly when tested in accordance with ASTM E814 or UL1479 with a minimum positive pressure differential of 0.01 in. of water.

2.5.1.2 *Through-penetration firestop system:* Where an approved through-penetration firestop system is required to protect a penetration through a fire-resistance-rated assembly, the assembly shall be permitted to be designed in accordance with Chapter 3, and the firestop system shall have an F and T rating no less than the fire-resistance rating of the fire-resistance-rated assembly when tested in accordance with ASTM E814 or UL 1479 with a minimum positive pressure differential of 0.01 in. of water.

2.5.1.3 *Fire-resistant joint system:* Where an approved fire-resistant joint system is required for a designed joint between fire-resistance-rated assemblies, the assemblies shall be permitted to be designed in accordance with Chapter 3 and the fire-resistant joint system shall be tested in accordance with ASTM E1966 or UL 2079.

2.5.2 Fireblocking

In wood construction, fireblocking shall be installed to restrict the passage of flames within and between concealed spaces constructed using exposed combustible materials. Fireblocking materials shall be in accordance with 2.5.2.1. Fireblocking shall be installed in the locations specified in 2.5.2.2 through 2.5.2.5 and as specified by the applicable building code. The integrity of fireblocking shall be maintained permanently. If the fireblocking is removed to allow temporary access or construction, it shall be replaced immediately after access or construction is completed.

2.5.2.1 *Fireblocking materials:* The following materials shall be permitted for fireblocking:

1. One layer of 2-inch (nominal) lumber, (1½-inch thickness).
2. One layer of minimum 1⅛-inch thick structural composite lumber.
3. One layer of minimum 1⅛-inch thick engineered wood rim board.
4. Two layers of 1-inch (nominal) lumber, (¾-inch thickness); abutting ends and edges in adjacent layers spaced at least 2 inches apart.
5. One layer of 23/32-inch wood structural panels with all panel edges backed by 23/32-inch wood structural panels, wood framing, or wood blocking.
6. One layer of ¾-inch particleboard with all panel edges backed by ¾-inch particleboard, wood framing, or wood blocking.
7. One layer of 1/2-inch gypsum panel product; with all panel edges backed by wood framing or wood blocking.
8. One layer of 1/4-inch cement-based millboard; with all panel edges backed by wood framing or wood blocking.
9. Batts or blankets of minimum 2.5 pcf mineral wool filling the entire cross section of the wall cavity, installed to be securely retained in place, and tightly packed around piping, conduit, or similar obstructions.
10. Wood members and wood protection materials designed in accordance with Chapter 3 to limit the passage of flames for at least 15 minutes.

2.5.2.2 *Concealed wall cavities:* Concealed spaces of stud walls and partitions, which include furred spaces and spaces within double walls, double-stud walls, and staggered stud walls, shall have fireblocking in accordance with 2.5.2.2.1 and 2.5.2.2.2.

2.5.2.2.1 *Horizontal intervals:* Fireblocking shall be provided for the full height of the cavity, at horizontal intervals not exceeding 10 feet.

EXCEPTION: Fireblocking is not required where batts or blankets of mineral wool, fiberglass or other approved nonrigid materials are installed such that they prevent the movement of hot air and gases and will remain in place.

2.5.2.2.2 *Vertical intervals:* Fireblocking shall be installed at the ceiling and floor levels for the full length of the wall.

2.5.2.3 *Intersection of concealed spaces:*

Fireblocking shall be provided at intersections between concealed spaces within wall assemblies and concealed spaces within floor/ceiling and roof/ceiling assemblies, and at intersections between concealed spaces in other locations such as occur at soffits, drop ceilings, and cove ceilings.

2.5.2.4 *Stairways:* Fireblocking shall be provided in concealed spaces between stair stringers at the top and bottom of the stair run.

2.5.2.5 *Concealed sleeper spaces:* Where wood sleepers are used for laying wood flooring on masonry or concrete fire-resistance-rated floors, the concealed space between the floor and the underside of the wood flooring shall meet one of the following:

1. The concealed space between the floor slab and the underside of the wood flooring shall be filled with an approved material to resist the free passage of flame and products of combustion; or,
2. Fireblocking shall be installed to limit open spaces under the flooring to no more than 100 square feet and also beneath permanent partitions to prevent fire spread between adjoining rooms.

2.5.3 Draftstopping

In wood construction, draftstopping shall be installed to subdivide large areas and restrict the movement of air and hot gases between combustible concealed spaces within floor-ceiling assemblies, and within attic spaces. Draftstopping materials shall be in accordance with 2.5.3.1. The integrity of draftstopping shall be maintained permanently. If the draftstopping is removed to allow temporary access or construction, it shall be replaced immediately after access or construction is completed.

2.5.3.1 *Draftstopping materials:* The following materials shall be permitted for draftstopping:

1. 1/2-inch gypsum panel product
2. 3/8-inch wood structural panel
3. 3/8-inch particleboard
4. 1-inch (nominal) lumber, (¾-inch thickness)
5. Cement fiberboard
6. Batts or blankets of mineral wool or glass fiber insulation, adequately supported

2.5.3.2 *Draftstopping in floors:* Draftstopping shall be installed to divide concealed spaces within floor/ceiling assemblies constructed using wood or wood-based materials so that horizontal areas of concealed spaces do not exceed 1,000 square feet.

EXCEPTION: Buildings equipped throughout with an automatic sprinkler system.

2.5.3.3 *Draftstopping in attics:* Draftstopping shall be installed to divide attic spaces constructed using wood or wood-based materials such that horizontal areas do not exceed 3,000 square feet. Separate ventilation shall be provided for each attic space.

EXCEPTION: Buildings equipped throughout with an automatic sprinkler system.

3. FIRE RESISTANCE

3.1	General	21
3.2	Charring of Wood	22
3.3	Structural Fire Resistance of Exposed Wood Members	23
3.4	Protection of Structural Wood Members and Assemblies	28
3.5	Calculation of Structural Fire Resistance Time of Protected Wood Members and Assemblies	30
3.6	Calculation of Thermal Separation Time	30
3.7	Calculation of Burn-Through Time	31
3.8	Tested Fire-Resistance-Rated Assemblies	31
3.9	Component Additive Method for Assemblies	31
3.10	Design of Protected Connections	35
<hr/>		
	Table 3.3.1.2 Char Depth and Effective Char Depth	24
	Table 3.3.1.3 Effective Char Depth	24
	Table 3.3.2 Adjustment Factors for Fire Design	25
	Table 3.4.2.1 Fire Resistance Time for Type X Gypsum Panel Products	29
	Table 3.4.3.1 Fire Resistance Time for Protected Wood Surfaces	29
	Table 3.9.1.1.1 Structural Fire Resistance Times Assigned to Sawn Lumber or LVL, PSL, or LSL Studs	31
	Table 3.9.1.1.2 Structural Fire Resistance Times Assigned to Sawn Lumber or SCL Joists	32



Table 3.9.1.1.3a Structural Fire Resistance Times Assigned to Wood I-Joist Flanges	33
Table 3.9.1.1.3b Structural Fire Resistance Times Assigned to Wood I-Joist Web	34
Table 3.9.1.2a Added Protection Time Assigned to Wood Membrane	34
Table 3.9.1.2b Added Protection Time Assigned to Type X Gypsum Panel Membrane	34
Table 3.9.2.2 Added Protection Time Assigned to Insulation Membrane	35



3.1 General

3.1.1 Scope

Chapter 3 establishes fire resistance provisions for use where the required fire resistance of wood construction covered under the *National Design Specification*[®] (NDS[®]) for Wood Construction is determined by testing or calculation.

3.1.2 Fire Exposure

The provisions of Chapter 3 are based on the standard fire exposure and acceptance criteria specified in ASTM E119 or UL 263. Design fire scenarios, used to conduct performance-based designs, are outside the scope of this standard.

3.1.3 Fire-Resistance Rating

The fire-resistance rating of a member or assembly shall be based on the fire exposure and acceptance criteria specified in ASTM E119 or UL 263. Fire-resistance ratings shall be permitted to be determined using fire tests, calculations as prescribed herein, or engineering analyses based on comparison with fire tests of similar members or assemblies. Where a member or assembly is required to prevent passage of fire, the fire-resistance rating of that member or assembly shall be the least of the structural fire resistance time, the thermal separation time, and the burn-through time. Where a member or assembly is not required to prevent passage of fire, the fire-resistance rating of that member or assembly shall be the structural fire resistance time.

3.1.3.1 *Design requirements:* Each wood member or connection shall be designed in accordance with the NDS for all loads prescribed by the applicable building code. In addition, where required to be fire-resistance-rated, the wood member, assembly or connection shall be designed to support its design dead load plus any applied live, roof live, or snow loads for the required fire resistance time based on the ASTM E119 or UL 263 fire exposure.

3.1.3.2 *Reference design values:* Reference design values and specific design provisions applicable to wood members, assemblies, and connections shall be in accordance with the NDS and this standard. Application of adjustment factors to reference design values and use with reduced cross-sections shall be in accordance with 3.3.2.

3.1.3.3 *Test loads:* Where the fire-resistance rating is determined by testing, the total load (w_T) to be used in ASTM E119 or UL 263 fire resistance testing shall simulate a maximum design load unless limited design criteria are specified, and a corresponding reduced load is applied and reported. The total load (w_T) shall include the superimposed load (w_S) to be applied throughout a fire resistance test combined with the member or assembly dead load (w_D).

3.1.3.3.1 For wood-frame walls, the superimposed load (w_S) shall be determined in accordance with ASTM D6513.

3.1.3.3.2 For wood-frame floor-ceiling assemblies, the superimposed load (w_S) shall be determined in accordance with ASTM D7746.

3.1.3.3.3 For other members and assemblies, the maximum design load shall be determined based on the reference design value determined in accordance with the NDS multiplied by all applicable adjustment factors, except for C_D , K_F , ϕ , and λ . The superimposed load (w_S) shall be calculated as the total load (w_T) minus the member or assembly dead load (w_D):

$$w_S = w_T - w_D \quad (\text{Eq. 3.1-1})$$

3.1.3.3.4 The total load (w_T) shall be reported as a percentage of the maximum design load for the member, assembly, or connection.

3.1.3.4 *Design loads:* Where the fire-resistance rating is determined by calculation in accordance with the provisions of this Chapter, the design load used for calculating the fire-resistance time shall be determined in accordance with the NDS and this section.

3.1.3.4.1 *Allowable stress design (ASD):* Where required to be fire-resistance-rated, the total load (w_T) to be used to calculate the fire resistance time for a member, assembly, or a connection designed using ASD methods shall be the design dead load (w_D) plus the design gravity live loads (w_L), including applicable occupancy live load, roof live load, and snow load, supported by the member or assembly.

$$w_T = w_D + w_L \quad (\text{Eq. 3.1-2})$$

3.1.3.4.2 *Strength design (LRFD)*: Where a member, assembly, or a connection is designed using LRFD methods, the total load (w_{T-LRFD}) to be used to calculate the fire resistance time shall be calculated as follows:

$$w_{T-LRFD} = \frac{1.5(w_D + w_L)^2}{1.2w_D + 1.6w_L} \quad (\text{Eq. 3.1-3})$$

3.2 Charring of Wood

3.2.1 Char Rate of Exposed Wood Members

The non-linear char rate shall be estimated from published nominal 1-hour char rate data using the following equation:

$$\beta_t t^{0.813} = \beta_n t \quad (\text{at } t = 1 \text{ hr}) \quad (\text{Eq. 3.2-1})$$

where:

- β_t = Non-linear char rate constant (in./hr^{0.813}), adjusted for exposure time, t
- β_n = Nominal char rate constant (in./hr), linear char rate based on 1-hour exposure
- t = Exposure time (hr)

3.2.1.1 *Standard Char Rate*: A nominal char rate, β_n , of 1.5 in./hr shall be applicable for sawn lumber, structural glued laminated softwood timber, laminated veneer lumber, parallel strand lumber, laminated strand lumber, and cross-laminated timber.

3.2.2 Char Depth, a_{char}

3.2.2.1 For sawn lumber, structural glued laminated timber, laminated veneer lumber, parallel strand lumber, and laminated strand lumber, the char depth, a_{char} , for each exposed surface shall be calculated as:

$$a_{char} = \beta_t t^{0.813} \quad (\text{Eq. 3.2-2})$$

3.2.2.2 For cross-laminated timber, the time required to reach the glue line for each lamination shall be calculated as:

$$t_{gl,i} = \left(\frac{h_{lam,i}}{\beta_t} \right)^{1.23} \quad (\text{Eq. 3.2-3})$$

where:

- $t_{gl,i}$ = time to char through lamination i (hr)
- $h_{lam,i}$ = thickness of lamination i (in.)

The number of laminations fully charred through, n_{lam} , shall be calculated by subtracting the sum of times

to char through each fully charred lamination, $t_{gl,i}$, from the total exposure time, t . The value of n_{lam} shall be the maximum integer value in which the following equation is true:

$$t - \sum_{i=1}^{n_{lam}} t_{gl,i} \geq 0 \quad (\text{Eq. 3.2-4})$$

where:

- n_{lam} = number of laminations fully charred (truncated integer)

The values of $t_{gl,i}$ and n_{lam} determined in the Equations 3.2-3 and 3.2-4, respectively, shall be used to calculate the char depth, a_{char} :

$$a_{char} = \sum_{i=1}^{n_{lam}} h_{lam,i} + \beta_t \left(t - \sum_{i=1}^{n_{lam}} t_{gl,i} \right)^{0.813}$$

(Eq. 3.2-5a)

3.2.2.3 Alternately, for cross-laminated timber manufactured with laminations of equal thickness, h_{lam} , the char depth, a_{char} , shall be permitted to be calculated using the time to char through one lamination, t_{gl} , and the following equation:

$$a_{char} = n_{lam} \cdot h_{lam} + \beta_t \left(t - (n_{lam} \cdot t_{gl}) \right)^{0.813} \quad (\text{Eq. 3.2-5b})$$

where:

$$t_{gl} = \left(\frac{h_{lam}}{\beta_t} \right)^{1.23} \quad (\text{Eq. 3.2-6})$$

$$n_{lam} = \frac{t}{t_{gl}} \quad (\text{Eq. 3.2-7})$$

3.2.2.4 Where approved, the char depth, a_{char} , of cross-laminated timber shall be permitted to be determined using a more detailed analysis accounting for the charring of solid wood cross-sections in

accordance with 3.2.2.1 and char penetration between laminations in each layer in accordance with 3.2.3.

3.2.3 Char Penetration at Intersections and Abutting Edges

Intersections and abutting edges of exposed wood members shall be designed in accordance with 3.2.3.1 through 3.2.3.4.

3.2.3.1 For exposed wood members with intersections or abutting edges that are protected on the exposed side with an approved fire-resistant joint system in accordance with 2.5.1.3, the char front shall be assumed to penetrate between wood members a distance equal to a_{char} .

3.2.3.2 For exposed wood members with intersections or abutting edges that are in contact or have a gap less than or equal to 1/8 inch, the char front shall be assumed to penetrate between wood members a distance equal to $2a_{char}$ (see Figure 3.1), provided that air flow through the gap does not occur. Air flow through the gap is permitted to be neglected where one of the following occurs:

1. The intersection is detailed to prevent burn-through in accordance with 3.7.
2. Draftstopping material as listed in 2.5.3.1, excluding fiberglass and mineral wool batts, is installed on the unexposed side of the assembly.
3. Adhesives or sealants meeting ASTM C920 or ASTM D3498 are applied in the gap on the unexposed side of the assembly.

4. The intersection occurs entirely within a single compartment such that the gap does not provide for air passage between compartments.

3.2.3.3 For exposed wood members with intersections or abutting edges that are initially in contact or have a gap less than or equal to 1/8-inch but where air flow between members cannot be prevented, wood surfaces within the intersection or abutting edge shall be assumed to be fully exposed to fire for the full depth of the intersection or abutting edge.

3.2.3.4 For exposed wood members with intersections or abutting edges that have a gap greater than 1/8-inch, wood surfaces within the intersection or abutting edge shall be assumed to be fully exposed to fire for the full depth of the intersection or abutting edge.

Figure 3.1 Char Penetration at Abutting Wood Members that are Unbonded

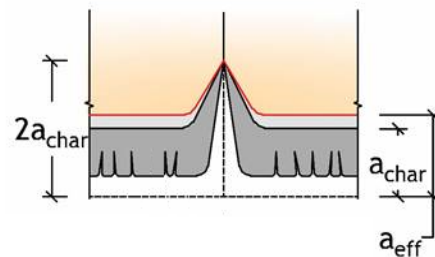

3.3 Structural Fire Resistance of Exposed Wood Members

Design of exposed wood members for structural fire resistance shall be in accordance with this section. The induced stress shall not exceed the resisting strength which has been adjusted for fire exposure. Design provisions for exposed wood members herein are limited to fire resistance calculations not exceeding 2 hours.

3.3.1 Effective Char Depth, a_{eff}

3.3.1.1 For structural calculations, section properties shall be based on reduced cross-sectional dimensions to account for charring and the effects of elevated temperature. Except as provided in 3.3.1.4 for specific bearing conditions, the initial cross-sectional

dimensions shall be reduced by the effective char depth, a_{eff} , for each surface exposed to fire, where:

$$a_{eff} = 1.2 a_{char} \quad (\text{Eq. 3.3-1})$$

3.3.1.2 For sawn lumber and timbers, structural glued laminated timber, laminated veneer lumber (LVL), parallel strand lumber (PSL), and laminated strand lumber (LSL), section properties for use in structural fire resistance calculations shall be determined using standard equations for area, section modulus, and moment of inertia using the reduced cross-sectional dimensions based on effective char depth as determined in accordance with 3.3.1.1.

Assuming a nominal char rate, $\beta_n=1.5$ in./hr, the char depth, a_{char} , and effective char depth, a_{eff} , are provided in Table 3.3.1.2.

Table 3.3.1.2 Char Depth and Effective Char Depth (for $\beta_n = 1.5$ inches/hour)

Required Fire-Resistance Rating (hr.)	Char Depth, a_{char} (in.)	Effective Char Depth, a_{eff} (in.)
1-hour	1.5	1.8
1-1/2-hour	2.1	2.5
2-hour	2.6	3.2

3.3.1.3 For cross-laminated timber, section properties for use in structural fire-resistance calculations shall be determined based on effective char depth as determined in accordance with 3.3.1.1 and design values provided by the cross-laminated timber manufacturer's approved recommendations or approved evaluation report, based on the actual layup provided. For cross-laminated timber manufactured with laminations of equal thickness and assuming a nominal char rate, β_n , of 1.5 in./hr, the char depth, a_{char} , and effective char depth, a_{eff} , are provided for each exposed surface in Table 3.3.1.3.

Table 3.3.1.3 Effective Char Depth (for CLT with $\beta_n=1.5$ inches/hour)

Required Fire-Resistance Rating (hr)	Lamination Thickness, h_{lam} (in.)								
	5/8	3/4	7/8	1	1-1/4	1-3/8	1-1/2	1-3/4	2
	Char Depth, a_{char} (in.)								
1-hour	1.8	1.8	1.7	1.7	1.7	1.6	1.5	1.5	1.5
1-1/2-hour	2.8	2.7	2.6	2.5	2.4	2.4	2.4	2.3	2.2
2-hour	3.7	3.6	3.4	3.4	3.2	3.2	3.0	3.0	3.0
	Effective Char Depth, a_{eff} (in.)								
1-hour	2.2	2.2	2.1	2.0	2.0	1.9	1.8	1.8	1.8
1-1/2-hour	3.4	3.2	3.1	3.0	2.9	2.8	2.8	2.8	2.6
2-hour	4.4	4.3	4.1	4.0	3.9	3.8	3.6	3.6	3.6

Alternatively, for CLT layups in Annex A of APA PRG 320, the cross-laminated timber is permitted to be designed using properties for one of the tabulated CLT layups in Annex A where the number of laminations does not exceed the number of uncharred laminations remaining after the effective char depth, from Table 3.3.1.3, has been removed.

3.3.1.4 *Effective char depth for bearing:* For design of bearing perpendicular-to-grain, dimensions of the bearing area, measured from each exposed edge of the bearing interface, shall be reduced by the effective char depth for bearing, $a_{eff(bearing)}$, where:

$$a_{eff(bearing)} = 1.5 a_{char} \quad (\text{Eq. 3.3-2})$$

3.3.2 Member Strength

For sawn lumber, structural glued laminated softwood timber, laminated veneer lumber, parallel strand lumber, laminated strand lumber, and cross-laminated timber, the design strength used to determine fire resistance shall be determined by multiplying reference design values (F_b , F_{bE} , F_t , F_v , F_c , F_{cE} , $F_{c\perp}$) by the adjustment factors specified in Table 3.3.2. All design values and cross-sectional properties shall be adjusted prior to structural calculations, including structural interaction equations, in the NDS provisions.

Table 3.3.2 Adjustment Factors for Fire Design^{1, 2}

Design Strength used to Determine Fire Resistance			Design Stress to Member Strength Factor, K	ASD or LRFD					
				Size Factor ³	Volume Factor ³	Flat Use Factor ³	Repetitive Member Factor	Beam Stability Factor ⁴	Column Stability Factor ⁴
Bending Strength	F _b	X	2.85	C _F	C _V	C _{Fu}	C _r	C _L	-
Beam Buckling Strength	F _{bE}	X	2.03	-	-	-	-	-	-
Tensile Strength	F _t	X	2.85	C _F	-	-	-	-	-
Shear Strength	F _v	X	2.75	-	-	-	-	-	-
Compressive Strength	F _c	X	2.58	C _F	-	-	-	-	C _P
Column Buckling Strength	F _{cE}	X	2.03	-	-	-	-	-	-
Bearing Strength	F _{c⊥}	X	1.67						

¹ See NDS for applicability of adjustment factors for specific products.

² Member strengths shall not be adjusted for C_D, C_M, nor C_t since these adjustments are addressed in the design stress to member strength factor.

³ Factor shall be based on initial cross-section dimensions.

⁴ Factor shall be based on reduced cross-section dimensions.

3.3.3 Design of Members

Induced stresses calculated using the design loads determined in 3.1.3.4 and the reduced section properties determined in 3.3.1 shall not exceed the member strength determined in 3.3.2.

3.3.3.1 *Special provisions for lumber decking:* Lumber decking shall consist of tongue-and-groove (T&G) planks or mechanically-laminated dimension lumber set on edge and nailed to the adjacent pieces. Mechanically-laminated decking shall be designed as an assembly of wood beams partially exposed on the sides due to shrinkage and char contraction and fully exposed on the bottom face. Abutting edges of exposed lumber decking shall be designed in accordance with 3.2.3.

EXCEPTIONS:

1. Single and double tongue-and-groove (T&G) decking shall be permitted to be designed as an assembly of wood beams fully exposed only on the bottom face.
2. For mechanically-laminated decking, the effects of partial exposure on the sides of the individual decking laminations shall be permitted to be designed assuming wood surfaces between laminations have an effective char depth that is 33% of the char depth for the fully exposed wood on the bottom face, extending for the full depth of the decking.

3.3.3.2 *Special provisions for structural glued laminated timber beams:* For structural glued laminated timber bending members that are required to have a fire-resistance rating and are manufactured with

multiple lamination grades throughout the depth, the following additional layup requirements shall apply in addition to any requirements of the structural design:

1. For structural glued laminated timber bending members required to have a fire-resistance rating of up to 1 hour, the beam shall be manufactured to the specified layup except that:
 - a. For unbalanced beams with the top of the beam not exposed to fire, a nominal 2-inch core lamination shall be removed, and an additional nominal 2-inch outer tension lamination shall be placed adjacent to the outer tension lamination as shown in Figure 3.2.
 - b. For unbalanced beams with the top of the beam exposed to fire, two nominal 2-inch core laminations shall be removed, and an additional nominal 2-inch outer tension lamination and an additional nominal 2-inch outer compression lamination shall be placed adjacent to the outer tension lamination and the outer compression lamination, respectively, as shown in Figure 3.3.
 - c. For balanced beams with the top of the beam not exposed to fire, a nominal 2-inch core lamination shall be removed, and an additional nominal 2-inch outer tension lamination shall be placed adjacent to the outer tension lamination at the bottom of the beam as shown in Figure 3.2.
 - d. For balanced beams with the top of the beam exposed to fire, two nominal 2-inch

core laminations shall be removed, and an additional nominal 2-inch outer tension lamination shall be placed adjacent to the outer tension lamination at the top and bottom of the beam as shown in Figure 3.3.

2. For structural glued laminated timber bending members required to have a fire-resistance rating of greater than 1 hour and up to 2 hours, the beam shall be manufactured to the specified layup except that:
 - a. For unbalanced beams with the top of the beam not exposed to fire, two nominal 2-inch core laminations shall be removed, and two additional nominal 2-inch outer tension laminations shall be placed adjacent to the outer tension lamination as shown in Figure 3.2.
 - b. For unbalanced beams with the top of the beam exposed to fire, four nominal 2-inch core laminations shall be removed, and two additional nominal 2-inch outer tension laminations and two additional nominal 2-inch outer compression laminations shall be placed adjacent to the outer tension lamination and the outer compression lamination, respectively, as shown in Figure 3.3.
 - c. For balanced beams with the top of the beam not exposed to fire, two nominal 2-inch core laminations shall be removed, and two additional nominal 2-inch outer tension laminations shall be placed adjacent to the outer tension lamination at the bottom of the beam, as shown in Figure 3.2.
 - d. For balanced beams with the top of the beam exposed to fire, four nominal 2-inch core laminations shall be removed, and two additional nominal 2-inch outer tension laminations shall be placed adjacent to the outer tension lamination at the top and bottom of the beam as shown in Figure 3.3.

Figure 3.2 Top of Beam Not Exposed to Fire

TOP OF BEAM NOT EXPOSED TO FIRE

Unbalanced Layout			Balanced Layout		
Outer Compression	Outer Compression	Outer Compression	Outer Tension	Outer Tension	Outer Tension
Inner Compression	Inner Compression	Inner Compression	Inner Tension	Inner Tension	Inner Tension
Inner Compression	Inner Compression	Inner Compression	Inner Tension	Inner Tension	Inner Tension
Core	Core	Core	Core	Core	Core
Core	Core	Core	Core	Core	Core
Core	Core	Core	Core	Core	Core
Core	Core	Core	Core	Core	Core
Core	Core	Core	Core	Core	Core
Core	Inner Tension	Inner Tension	Core	Core	Inner Tension
Inner Tension	Inner Tension	Inner Tension	Core	Inner Tension	Inner Tension
Inner Tension	Additional Outer Tension	Additional Outer Tension	Inner Tension	Inner Tension	Additional Outer Tension
Outer Tension	Outer Tension	Outer Tension	Inner Tension	Additional Outer Tension	Additional Outer Tension
Outer Tension	Outer Tension	Outer Tension	Outer Tension	Outer Tension	Outer Tension
Unrated	One Hour	Two Hour	Unrated	One Hour	Two Hour

Figure 3.3 Top of Beam Exposed to Fire

TOP OF BEAM EXPOSED TO FIRE

Unbalanced Layout			Balanced Layout		
Outer Compression	Outer Compression	Outer Compression	Outer Tension	Outer Tension	Outer Tension
Inner Compression	Additional Outer Compression	Additional Outer Compression	Inner Tension	Additional Outer Tension	Additional Outer Tension
Inner Compression	Inner Compression	Additional Outer Compression	Inner Tension	Inner Tension	Additional Outer Tension
Core	Inner Compression	Inner Compression	Core	Inner Tension	Inner Tension
Core	Core	Inner Compression	Core	Core	Inner Tension
Core	Core	Core	Core	Core	Core
Core	Core	Core	Core	Core	Core
Core	Core	Inner Tension	Core	Core	Inner Tension
Core	Inner Tension	Inner Tension	Core	Inner Tension	Inner Tension
Inner Tension	Inner Tension	Additional Outer Tension	Inner Tension	Inner Tension	Additional Outer Tension
Inner Tension	Additional Outer Tension	Additional Outer Tension	Inner Tension	Additional Outer Tension	Additional Outer Tension
Outer Tension	Outer Tension	Outer Tension	Outer Tension	Outer Tension	Outer Tension
Unrated	One Hour	Two Hour	Unrated	One Hour	Two Hour

3.4 Protection of Structural Wood Members and Assemblies

Where protective materials are used to increase the fire resistance of structural wood members, the structural fire resistance times of protected wood members shall be permitted to be calculated in accordance with 3.2, except with delayed onset of charring of each protected surface. The protection time, t_p , from the protective material shall be determined either by testing or using assigned values and calculations in accordance with this section. The protection times assigned in 3.4.1 through 3.4.3 shall be permitted to be used to estimate the delayed onset of charring of each protected surface. Where all surfaces of the structural wood member are protected with the same protection system, such as one or more protective membranes, the protection times of the protection system are directly additive with the structural fire resistance times of the structural wood members calculated in 3.2.

3.4.1 Protection by Wood

Wood cover shall be permitted as protection to increase fire resistance of structural wood members and assemblies.

3.4.1.1 *Wood cover in contact with protected member:* The protection time, t_p , provided by each layer of wood cover that is in contact with either the protected member or another underlying layer of protection shall be calculated as:

$$t_p = 60 \left(\frac{d_p}{\beta_t} \right)^{1.23} \text{ minutes} \quad (\text{Eq. 3.4-1})$$

where:

d_p = thickness of the protective layer of wood (in.)

β_t = non-linear char rate constant (in./hr^{0.813})

For a nominal char rate of 1.5 in./hr, the non-linear char rate constant is calculated as $\beta_t = 1.5 \text{ in./hr}^{0.813}$, and the protection time associated with a protective wood membrane of a thickness, d , shall be calculated as follows:

$$t_p = 60 \left(\frac{d_p}{1.5} \right)^{1.23} \text{ minutes} \quad (\text{Eq. 3.4-2})$$

3.4.1.2 *Wood cover not in contact with protected member:* The protection time, t_p , provided by a layer of wood cover that is not in contact with the protected

member or another underlying layer of protection shall be calculated as follows:

$$t_p = \left[60 \left(\frac{d_p - 0.6}{1.5} \right)^{1.23} + 17 \right] \text{ minutes for } d_p \geq 0.6 \text{ inches} \quad (\text{Eq. 3.4-3a})$$

$$t_p = 60 \left(\frac{d_p}{2.1} \right) \text{ minutes for } d_p < 0.6 \text{ inches} \quad (\text{Eq. 3.4-3b})$$

3.4.1.3 *Wood membrane:* Where wood cover is used as a membrane to protect the entire wood member or assembly, the protection time calculated in 3.4.1.1 or 3.4.1.2 shall be the added protection time.

3.4.1.4 *Fasteners attaching wood protection:* Each layer of the wood cover shall be attached with fasteners of sufficient length to penetrate the protected wood member or underlying layers of wood cover, for a total depth of at least one inch. Fasteners attaching wood protection shall not be required to be protected.

3.4.1.5 *Intersections and abutting edges of exposed wood cover:* Intersections and abutting edges between wood members and wood cover or between wood cover elements shall be designed in accordance with 3.2.3. Additional protection shall be provided at gaps, as necessary, to ensure that the wood cover provides the required protection.

3.4.2 Protection by Type X Gypsum Panel Products

Fire-rated gypsum panel products (Type X) shall be permitted as protection to increase fire resistance of wood members and assemblies.

3.4.2.1 *Gypsum panel cover:* Where used to increase fire resistance of wood members, the protection time, t_p , provided by each layer of Type X gypsum panel cover that is in contact with either the protected member or another underlying layer of protection shall be as provided in Table 3.4.2.1.

3.4.2.2 *Gypsum panel membrane:* Where Type X gypsum panels are used as a membrane to protect the entire wood member or assembly, the protection time, t_p , provided by each layer of Type X gypsum panels shall be in accordance with Table 3.4.2.1.

Table 3.4.2.1 Fire Resistance Time for Type X Gypsum Panel Products

Gypsum Panel Product ¹	Gypsum Panel Cover of Members ^{2, 3}	Gypsum Panel Membrane Protection of Members and Assemblies ^{4, 5, 6, 7}		Protection Time, <i>t_p</i> (minutes)
	Maximum Fastener Spacing (in.)	Maximum Framing Spacing (in.)	Maximum Fastener Spacing (in.)	
1/2-inch Type X	12	16 24	12 8	30 ⁸
5/8-inch Type X	12	16 24	12 8	40 ⁹

- ¹ Each gypsum panel layer shall be attached with fasteners of sufficient length to penetrate the wood member at least 1 inch or be attached to steel channels capable of supporting the weight of the gypsum panel.
- ² Where multiple layers of gypsum panels are required, all adjoining panel edges shall be offset at least 16 inches from those of the adjacent underlying layer and attached with fasteners offset at least 4 inches in both orthogonal directions from the fasteners in all underlying layers.
- ³ Gypsum panel cover attached to wood members shall be installed such that gypsum panel cover at outside corners overlaps by at least the thickness of the gypsum panel. For gypsum panel cover attached to horizontal wood members (e.g., wood beams), side layers are installed first, followed by the bottom layer(s) to ensure that the edges of the side layers are covered.
- ⁴ Panel edges of the gypsum panel membrane face layer shall be taped and finished with joint compound, and fastener heads shall be covered with joint compound.
- ⁵ Where multiple layers of gypsum panels are required, adjoining panel edges occurring over framing shall be staggered at least one framing spacing from those of the adjacent underlying layer and attached to framing with fasteners offset at least 4 inches from the fasteners in all underlying layers. Unbacked adjoining panel edges shall be offset by at least 12 inches from those of the adjacent underlying layer.
- ⁶ At wall-to-ceiling intersections, the gypsum panel membrane shall be installed such that the ceiling gypsum panel membrane is installed first, followed by the wall gypsum panel membrane to ensure that the ceiling gypsum panel membrane is supported by each layer of the wall gypsum panel membrane.
- ⁷ At wall-to-wall intersections, each layer of the gypsum panel membrane shall be installed such that the gypsum panel membrane on the wall with a greater fire-resistance rating is installed first, followed by the gypsum panel membrane on the intersecting wall.
- ⁸ For wood-frame walls with studs spaced 16 inches on center or less, the protection time, *t_p*, for 1/2" Type X gypsum panel, with 2-1/4" Type S drywall screws spaced at 7 inches on center or less, shall be permitted to be increased to 33 minutes for a single layer or a base layer of 1/2" Type X gypsum panel. Additional layers of 1/2" Type X gypsum panel are limited to 30 minutes/layer.
- ⁹ For wood-frame walls with studs spaced 24 inches on center or less, the protection time, *t_p*, for 5/8" Type X gypsum panel, with 2-1/4" Type S drywall screws spaced at 7 inches on center or less, shall be permitted to be increased to 48 minutes for a single layer or a base layer of 5/8" Type X gypsum panel.

3.4.2.3 *Fasteners attaching gypsum panel products:* Each Type X gypsum panel layer shall be attached with fasteners of sufficient length to penetrate the wood member at least 1 inch or be attached to steel channels capable of supporting the weight of the gypsum panel. Fasteners attaching gypsum panel shall not be required to be protected.

3.4.2.4 *Gypsum panel product contraction:* Where Type X gypsum panel contraction will cause gaps to form at edges of gypsum panels that are initially considered to be in contact, ignition of combustible materials directly behind the gaps shall be assumed to occur at the time assigned to that Type X gypsum panel layer, determined in 3.4.2.1 or 3.4.2.2, multiplied by 0.50. Additional protection shall be provided at the gaps, as necessary, to ensure that the Type X gypsum panel provides the required protection.

3.4.3 Protection by Insulation

Mineral wool and fiberglass insulation shall be permitted as protection to increase fire resistance of wood members and assemblies.

3.4.3.1 *Insulation cover:* Where used to increase fire resistance of wood members or assemblies, the protection time, *t_p*, provided by mineral wool or fiberglass insulation batts of the specified minimum thickness and density or R-value, shall be as provided in Table 3.4.3.1. Protection times specified in Table 3.4.3.1 shall not be additive with each other and shall not be increased for additional insulation thickness, density, or R-value.

3.4.3.2 *Insulation as part of a membrane:* Where mineral wool or fiberglass insulation batts are used as part of a membrane to protect the entire wood member or assembly, the protection time calculated in Table 3.4.3.1 shall be the added protection time. Protection times specified in Table 3.4.3.1 shall not be additive with each other and shall not be increased for additional insulation thickness, density, or R-value.

Table 3.4.3.1 Fire Resistance Time for Protected Wood Surfaces

Insulation Description	Minimum Thickness (in.)	Protection Time, <i>t_p</i> (minutes)
Mineral wool batts (minimum nominal density: 2.5 pcf)	3.5	19
	1.5	17
Fiberglass batts (minimum R-13)	3.5	3

3.5 Calculation of Structural Fire Resistance Time of Protected Wood Members and Assemblies

The structural fire resistance time for protected wood members and assemblies shall be permitted to be calculated in accordance with 3.2, accounting for delayed charring on each protected surface in accordance with 3.4. Wood members or assemblies protected with one or more of the protection options in

3.4 shall be permitted to exceed the 2-hour limitation on calculated fire resistance for exposed wood members in 3.2; however, the calculated contribution of the wood members to the structural fire resistance shall not exceed 2 hours.

3.6 Calculation of Thermal Separation Time

The calculated thermal separation time provided by an assembly shall be equal to the sum of the times assigned to the protective membranes on both the fire-exposed side of the assembly and the unexposed side of the assembly, and additional contribution by other protective components such as insulation. Where the calculated thermal separation time for a structural assembly exceeds the structural fire resistance time, the thermal separation time shall be limited to the structural fire resistance time.

3.6.1 Thermal Separation Time Provided by Wood Layers

3.6.1.1 *Wood cover or membranes:* The contribution of wood layers to the thermal separation time shall be equal to the sum of protection times assigned to each layer, determined in 3.4.1, except where a single layer of wood is used to provide thermal separation or where the final layer on the unexposed side of the thermal separation is wood, the time assigned to that wood layer, as determined in 3.4.1, shall be multiplied by 0.85.

3.6.1.2 *Intersections and abutting edges of exposed wood cover:* Intersections and abutting edges between wood members and wood cover or between wood cover elements shall be designed in accordance with 3.2.3. Where char penetration will cause gaps to form between wood members or wood cover that are initially considered to be in contact, additional protection shall be provided, as necessary, to ensure that wood members or wood cover provide the required thermal separation time.

3.6.2 Thermal Separation Time Provided by Type X Gypsum Panel Products

3.6.2.1 *Gypsum panel cover or membranes:* The contribution of Type X gypsum panel layers to the thermal separation time shall be equal to the sum of protection times assigned to each layer, determined in 3.4.2, except where a single layer of Type X gypsum panel is used to provide thermal separation or where the final layer on the unexposed side of the thermal separation is Type X gypsum panel, the time assigned to that Type X gypsum panel layer, determined in 3.4.2, shall be multiplied by 0.50.

3.6.2.2 *Gypsum panel product contraction:* Where Type X gypsum panel contraction will cause gaps to form between adjoining gypsum panels that are initially considered to be in contact, ignition of combustible materials directly behind the gaps shall be assumed to occur at the time assigned to that Type X gypsum panel layer, determined in 3.4.2, multiplied by 0.50; however, the effect on the thermal separation time, estimated in 3.6.2.1, shall be permitted to be ignored.

3.6.3 Thermal Separation Time Provided by Insulation

3.6.3.1 *Insulation protection time:* Where insulation is used to provide a portion of the thermal separation, the protection time, t_p , determined in 3.4.3, shall be permitted to be added. Protection times specified in Table 3.3.3.1 shall not be additive with each other and shall not be increased for additional insulation thickness, density, or R-value.

3.7 Calculation of Burn-Through Time

Where thermal separation is required, detailing shall be provided to prevent burn-through before the required thermal separation time is reached. Determination of burn-through time shall account for

the effects of char penetration between wood members or wood cover in accordance with 3.6.1.2, and for the effects of Type X gypsum panel product contraction in accordance with 3.6.2.2.

3.8 Tested Fire-Resistance-Rated Assemblies

Assemblies tested in accordance with ASTM E119 or UL 263 are provided in Supplement B. Supplement B1 and B2 provide a listing of reported wall assemblies meeting specified 1-hr and 2-hr fire-resistance ratings,

respectively. Supplement B3 and B4 provide a listing of reported floor/ceiling and roof/ceiling assemblies meeting specified 1-hr and 2-hr fire-resistance ratings, respectively.

3.9 Component Additive Method for Assemblies

The fire-resistance ratings of wall assemblies, floor/ceiling assemblies, and roof/ceiling assemblies shall be permitted to be calculated using the provisions of this section which are based on ASTM E119 or UL 263 test data. The fire-resistance rating shall be the minimum time determined from the structural fire resistance time calculated in 3.9.1 and the thermal separation time calculated in 3.9.2.

on the fire-exposed side in accordance with 3.9.1.2. The membrane on the unexposed side shall not be included in determining the structural fire resistance time of the assembly.

3.9.1 Calculating the Structural Fire Resistance Time

The structural fire resistance time of an assembly shall be equal to the sum of the structural fire resistance times assigned to the members in 3.9.1.1 and the protection times assigned to the protective membrane

3.9.1.1 *Fire resistance times for wood members in assemblies:* The structural fire resistance times for wood members in common assemblies are provided in 3.9.1.1.1 through 3.9.1.1.3.

3.9.1.1.1 *Sawn lumber, LVL, PSL, or LSL studs:* The structural fire resistance times for sawn lumber or LVL, PSL, or LSL studs in Table 3.9.1.1.1 shall be permitted for use with the component additive method of this section provided that the stress ratio for the studs does not exceed the tabulated value.

Table 3.9.1.1.1 Structural Fire Resistance Times Assigned to Sawn Lumber or LVL, PSL, or LSL Studs

Stud Size	Maximum Bearing Stress Ratio ¹ ($f_c / F_{c\perp}$)	Maximum Axial Compression Stress Ratio ^{2,3} (f_c / F_c')		Assigned Fire Resistance Time for Studs (minutes)		
		$K_e=1.0$ ²	$K_e=0.7$ ³	No Insulation	Mineral Wool ⁴ (min. 2.5 pcf)	Fiberglass ⁴ (min. R-13)
2x4	78%	100%	54%	10	23	12
	61%	78%	42%	12	26	14
2x6	100%	61%	42%	14	30	16

¹ The maximum Bearing Stress Ratio limits the allowable load on 2x6 studs as a result of the calculated compression perpendicular-to-grain stress, $F_{c\perp}$.

² The maximum Axial Compression Stress Ratio for $K_e=1.0$ limits the allowable load on 2x4 studs as a result of the calculated compression parallel-to-grain stress, F_c' , assuming concentric loading and pinned-end reactions at each end of studs.

³ The Axial Compression Stress Ratio for $K_e=0.7$ is the basis of the calculated fire resistance times and is based on the calculated compression parallel-to-grain stress, F_c' , assuming concentric loading and square-end bearing reactions at each end of studs.

⁴ Cavity between studs shall be filled completely with insulation.

3.9.1.1.2 *Sawn lumber, LVL, PSL, or LSL joists:*
The structural fire resistance times for sawn lumber

or LVL, PSL, or LSL joists in Table 3.9.1.1.2 shall be permitted for use with the component additive

method of this section, provided that the stress ratio for the joists does not exceed the tabulated value.

Table 3.9.1.1.2 Structural Fire Resistance Times Assigned to Sawn Lumber or SCL Joists ^{1, 2, 3} (protected surface on top edge)

	ASD Stress Ratio ⁴	2x6	2x8	2x10	2x12	Additional LVL, PSL, or LSL Sizes			
		1-1/2"x 5-1/2"	1-1/2"x 7-1/4"	1-1/2"x 9-1/4"	1-1/2"x 11-1/4"	1-1/2"x 9-1/2"	1-1/2"x 11-7/8"	1-3/4"x 9-1/2"	1-3/4"x 11-7/8"
Structural Fire Resistance Time for Joists (minutes)									
No Insulation	0.5	15.1	15.3	15.5	15.6	15.5	15.7	18.6	18.8
	0.6	14.1	14.4	14.6	14.7	14.6	14.8	17.5	17.7
	0.7	13.2	13.5	13.7	13.8	13.7	13.9	16.4	16.7
	0.8	12.3	12.6	12.8	13.0	12.9	13.0	15.4	15.6
	0.9	11.4	11.8	12.0	12.1	12.0	12.2	14.3	14.6
	1.0	10.6	10.9	11.2	11.3	11.2	11.4	13.3	13.6
Fiberglass Batt Insulation (min. R-13)	0.5	17.9	18.2	18.4	18.6	18.4	18.6	21.5	21.7
	0.6	16.9	17.2	17.5	17.6	17.5	17.7	20.4	20.6
	0.7	15.9	16.3	16.6	16.7	16.6	16.8	19.3	19.5
	0.8	15.0	15.4	15.7	15.9	15.7	15.9	18.2	18.5
	0.9	14.1	14.5	14.8	15.0	14.8	15.0	17.1	17.4
	1.0	13.3	13.7	14.0	14.2	14.0	14.2	16.1	16.4
Mineral Wool Batt (min. 1.5" thick, 2.5 pcf)	0.5	30.9	31.6	31.9	32.2	32.0	32.2	34.9	35.3
	0.6	29.8	30.5	30.9	31.2	31.0	31.3	33.7	34.1
	0.7	28.7	29.5	29.9	30.2	30.0	30.3	32.5	33.0
	0.8	27.6	28.5	29.0	29.3	29.0	29.4	31.3	31.8
	0.9	26.6	27.5	28.0	28.4	28.1	28.5	30.2	30.7
	1.0	25.7	26.5	27.1	27.5	27.2	27.6	29.1	29.7

¹ Values are applicable to joists that are continuously laterally supported such that $C_L = 1.0$.

² Interpolation shall be permitted.

³ Glulam joists of the sizes listed for sawn lumber or SCL joists shall be permitted for use with the component additive method and utilize the tabulated fire resistance times assigned for the ASD stress ratios.

⁴ Stress ratio is for f_b/F_b' . For cases where f_v/F_v' controls the design, the tabulated fire resistance time for the given stress ratio is slightly conservative.

3.9.1.1.3 Wood I-joists: The structural fire resistance time assigned to a wood I-joist, based on the lesser of the structural fire resistance times assigned to the flange in Table 3.9.1.1.3a and the web in Table 3.9.1.1.3b shall be permitted for use with the component additive method of this section. Alternatively, I-joist fire resistance times shall be permitted to be assumed as zero for the analysis.

Table 3.9.1.1.3a Structural Fire Resistance Times Assigned to Wood I-Joist Flanges¹

Insulation Description and Location	ASD Stress Ratio ²	I-Joists – Flange Dimensions (width x depth)							
		1-1/2" x 1-5/16"	1-1/2" x 1-1/2"	1-3/4" x 1-1/8"	1-3/4" x 1-1/4"	1-3/4" x 1-5/16"	2-5/16" x 1-1/8"	2-5/16" x 1-1/4"	3-1/2" x 1-1/2"
		Time (minutes) ³							
All flange surfaces exposed, no insulation	0.5	9.6	10.5	9.0	9.9	10.3	9.7	10.8	14.2
	0.6	8.8	9.6	8.3	9.1	9.5	9.0	10.0	13.2
	0.7	8.1	8.8	7.7	8.4	8.7	8.3	9.2	12.2
	0.8	7.4	8.1	7.0	7.7	8.0	7.7	8.5	11.3
	0.9	6.8	7.4	6.5	7.1	7.3	7.1	7.8	10.5
	1.0	6.2	6.8	5.9	6.5	6.7	6.5	7.2	9.6
Bottom and sides of flange exposed, top protected with fiberglass insulation (min. 3.5 in., R13)	0.5	10.4	11.2	10.1	10.9	11.3	11.0	12.0	15.5
	0.6	9.6	10.3	9.4	10.1	10.4	10.2	11.2	14.4
	0.7	8.9	9.6	8.7	9.4	9.7	9.5	10.4	13.5
	0.8	8.2	8.8	8.1	8.7	8.9	8.9	9.6	12.5
	0.9	7.6	8.2	7.5	8.0	8.3	8.3	9.0	11.7
	1.0	7.1	7.5	7.0	7.4	7.7	7.7	8.3	10.8
Bottom and sides of flange exposed, top protected with mineral wool insulation (min. 1.5 in., 2.5 pcf)	0.5	13.3	13.8	14.5	15.1	15.4	17.2	17.8	21.8
	0.6	12.3	12.7	13.3	13.9	14.1	16.1	17.0	20.7
	0.7	11.3	11.8	12.2	12.8	13.0	14.7	15.7	19.7
	0.8	10.5	10.9	11.2	11.7	12.0	13.5	14.4	18.7
	0.9	9.6	10.0	10.3	10.8	11.0	12.4	13.2	17.9
	1.0	8.8	9.2	9.4	9.9	10.1	11.3	12.1	17.1
Bottom exposed, top and sides of flange protected with fiberglass insulation (min. 3.5 in., R13)	0.5	10.0	10.8	9.7	10.4	10.8	10.6	11.5	14.8
	0.6	9.4	10.1	9.1	9.8	10.1	9.9	10.8	13.9
	0.7	8.9	9.5	8.6	9.2	9.5	9.3	10.1	13.0
	0.8	8.4	9.0	8.1	8.6	8.9	8.8	9.5	12.2
	0.9	7.9	8.5	7.6	8.1	8.4	8.3	8.9	11.4
	1.0	7.4	8.0	7.2	7.7	7.9	7.8	8.4	10.7
Bottom exposed, top and sides of flange protected with mineral wool insulation (min. 1.5 in., 2.5 pcf)	0.5	18.3	19.1	17.8	18.5	18.8	18.4	19.3	22.4
	0.6	17.8	18.6	17.3	18.0	18.3	17.9	18.7	21.6
	0.7	17.4	18.1	17.0	17.5	17.8	17.4	18.1	20.8
	0.8	17.1	17.7	16.0	17.1	17.4	17.1	17.7	20.1
	0.9	16.3	17.3	15.0	16.5	17.1	16.2	17.3	19.4
	1.0	15.4	17.0	14.0	15.5	16.2	15.1	16.8	18.8
All flange surfaces protected with mineral wool insulation (min. 1.5 in., 2.5 pcf)	0.5	26.6	27.5	26.0	26.9	27.3	26.7	27.8	31.2
	0.6	25.8	26.6	25.3	26.1	26.5	26.0	27.0	30.2
	0.7	25.1	25.8	24.7	25.4	25.7	25.3	26.2	29.2
	0.8	24.4	25.1	24.0	24.7	25.0	24.7	25.5	28.3
	0.9	23.8	24.4	23.5	24.1	24.3	24.1	24.8	27.5
	1.0	23.2	23.8	22.9	23.5	23.7	23.5	24.2	26.6
Top and sides of flange protected with mineral wool insulation (min. 1.5 in., 2.5 pcf), bottom protected with 3/4" wood strips	0.5	29.0	29.5	29.2	29.8	30.1	30.4	31.3	34.9
	0.6	28.2	28.7	28.4	29.0	29.2	29.6	30.4	33.9
	0.7	27.5	27.9	27.7	28.2	28.4	28.9	29.6	32.9
	0.8	26.8	27.2	27.1	27.5	27.7	28.2	28.8	31.9
	0.9	26.2	26.6	26.5	26.9	27.1	27.6	28.1	31.0
	1.0	25.7	26.0	26.0	26.3	26.5	27.0	27.5	30.2

¹ Assigned times shall be taken as the lesser of the times assigned to the flange and the web.

² Stress ratio is for ASD induced moment divided by ASD resisting moment of I-Joist.

³ Values are applicable to I-joists that are continuously laterally supported such that $C_L = 1.0$.

Table 3.9.1.1.3b Structural Fire Resistance Times Assigned to Wood I-Joist Web¹

Insulation Description and Location	I-Joists – Web Thickness		
	3/8"	7/16"	1/2"
	Time (minutes) ²		
Both faces exposed, no insulation	2	3	3
Both faces protected with fiberglass insulation (min. 3.5" thick, R13)	5	6	6
Both faces protected with mineral wool insulation (min. 1.5 in. thick, 2.5 pcf.)	19	20	20
Both faces protected with mineral wool insulation (min. 3.5 in. thick, 2.5 pcf.)	21	22	22

¹ Assigned times shall be taken as the lesser of the times assigned to the flange and the web.

² Times calculated assuming full ASD shear design stress ratio.

3.9.1.2 *Protection of wood members:* Where a membrane is used to protect wood members in an assembly, the added fire protection time shall be taken as sum of the protection time, t_p , assigned to wood membrane in Table 3.9.1.2a or to Type X gypsum panels in Table 3.9.1.2b

Table 3.9.1.2a Added Protection Time Assigned to Wood Membrane

Description of Wood Membrane	Max. Framing Spacing (in.)	Max. Fastener Spacing		Time (minutes)
		Panel Edge (in.)	Panel Field (in.)	
3/8-inch Wood Structural Panels	24	6	12	10
1/2-inch Wood Structural Panels	24	6	12	14
5/8-inch Wood Structural Panels	24	6	12	17
23/32-inch Wood Structural Panels	24	6	12	19

Interpolation shall be permitted based on panel thickness.

Table 3.9.1.2b Added Protection Time Assigned to Type X Gypsum Panel Membrane

Description of Gypsum Panel Membrane ^{1, 2, 3, 4, 5}	Max. Framing Spacing (in.)	Max. Fastener Spacing (in.)	Time, minutes
1/2-inch Type X gypsum panel product	16	12	30 ⁶
	24	8	
5/8-inch Type X gypsum panel product	16	12	40 ⁷
	24	8	

¹ Each gypsum panel layer shall be attached with fasteners of sufficient length to penetrate the wood member at least 1 inch or be attached to steel channels capable of supporting the weight of the gypsum panel.

² Panel edges of the gypsum panel face layer shall be taped and finished with joint compound and fastener heads shall be covered with joint compound.

³ Where multiple layers of gypsum panel are required, adjoining panel edges occurring over framing shall be staggered at least one framing spacing from those of the adjacent underlying layer and attached to framing with fasteners offset at least 4 inches from the fasteners in all underlying layers. Unbacked adjoining panel edges shall be offset by at least 12 inches from those of the adjacent underlying layer.

⁴ At wall-to-ceiling intersections, the gypsum panel membrane shall be installed such that the ceiling gypsum panel membrane is installed first, followed by the wall gypsum panel membrane to ensure that the ceiling gypsum panel membrane is supported by each layer of the wall gypsum panel membrane.

⁵ At wall-to-wall intersections, each layer of gypsum panel membrane shall be installed such that the gypsum panel membrane on the wall with a greater fire-resistance rating is installed first, followed by the gypsum panel membrane on the intersecting wall.

⁶ For wood-frame walls with studs spaced 16 inches on center or less, the protection time, t_p , for 1/2" Type X gypsum panel with 2-1/4" Type S drywall screws spaced at 7 inches on center or less shall be permitted to be increased to 33 minutes for a single layer or a base layer of 1/2" Type X gypsum panel. Additional layers of 1/2" Type X gypsum panel are limited to 30 minutes/layer.

⁷ For wood-frame walls with studs spaced 24 inches on center or less, the protection time, t_p , for 5/8" Type X gypsum panel with 2-1/4" Type S drywall screws spaced at 7 inches on center or less shall be permitted to be increased to 48 minutes for a single layer or a base layer of 5/8" Type X gypsum panel. Additional layers of 5/8" Type X gypsum panel are limited to 40 minutes/layer.

3.9.2 Calculating the Thermal Separation Time

The calculated thermal separation time provided by an assembly is equal to the sum of the times assigned to the protective membranes on both the fire-exposed side and the unexposed side, and additional contribution by other protective measures such as insulation. Where the calculated thermal separation time for a structural assembly exceeds the structural fire resistance time, the thermal separation time shall be limited to the structural fire resistance time.

3.9.2.1 *Contribution from membranes:* Thermal separation times assigned to protective membranes in Table 3.9.1.2a and Table 3.9.1.2b shall be permitted to be added except that, where a single layer of wood or

Type X gypsum panel is used to provide all of the thermal separation or where the final layer of thermal separation on the unexposed side of the assembly is a wood layer or Type X gypsum panel layer, the time assigned to that wood layer or Type X gypsum panel layer shall be multiplied by 0.85 or 0.50, respectively.

3.9.2.2 Contribution from insulation: Thermal separation times assigned to insulation, when incorporated into the assembly, shall be permitted to use the values in Table 3.9.2.2. Protection times specified in Table 3.9.2.2 shall not be additive with each other and shall not be increased for additional insulation thickness, density, or R-value.

Table 3.9.2.2 Added Protection Time Assigned to Insulation Membrane

Insulation Description	Minimum Thickness (in.)	Time, (minutes)
Mineral wool insulation (minimum nominal density: 2.5 pcf)	3.5	19
	1.5	15
Fiberglass insulation (minimum R-13)	3.5	3

3.10 Design of Protected Connections

Where a member or an assembly is required to have a fire-resistance rating, structural connections to that member or assembly shall be protected from fire exposure for the time corresponding to the required fire-resistance rating of the member or assembly. All components of the structural connection, including connectors, fasteners and portions of the connected members that are part of the structural connection, shall be protected. Protection of the structural connection shall be provided by wood, Type X gypsum panel, other approved materials, or a combination thereof. Each wood cover layer shall be attached with fasteners of sufficient length to penetrate the adjacent member or cover at least one inch. Fasteners attaching the protection shall not be required to be protected; however, wood cover shall be attached in accordance with 3.4.1.4 and Type X gypsum panel protection shall be attached in accordance with 3.4.2.3.

EXCEPTION: Wood structural connections within a fire-resistance-rated assembly shall be considered to have the fire-resistance rating of the assembly without additional protection.

3.10.1 Connection Protection

Design of the protection shall be in accordance with the thermal separation provisions of 3.6.1 for wood protection and 3.6.2 for Type X gypsum panel protection.

EXCEPTION: Connections in fire-resistance-rated assemblies tested in accordance with ASTM E119 or UL 263.

3.10.2 Intersections and Abutting Edges of Exposed Wood Members and Wood Cover

Char penetration between intersections and abutting edges of exposed wood members and wood cover shall be designed in accordance with 3.2.3. Protection of connections at ends and edges of wood members shall address this penetration to ensure the provisions of 3.10.1 are met.



REFERENCES



REFERENCES

1. ANSI A190.1-2017 *Standard for Wood Products — Structural Glued Laminated Timber*. APA – The Engineered Wood Association, Tacoma, WA, 2017.
2. ANSI A208.1-2016 *Particleboard Standard*. Composite Panel Association, Leesburg, VA, 2016.
3. ANSI 405-2018 *Standard for Adhesives for Use in Structural Glued Laminated Timber*. APA – The Engineered Wood Association, Tacoma, WA, 2018.
4. ANSI/ASME B18.2.1-2012 *Square, Hex, Heavy Hex, and Askew Head Bolts and Hex, Heavy Hex, Hex Flange, Lobed Head, and Lag Screws (Inch Series)*. American Society of Mechanical Engineers, New York, NY, 2012.
5. ANSI/ASME B18.6.1-1981(R2016) *Wood Screws (Inch Series)*. American Society of Mechanical Engineers, New York, NY, 2016.
6. ASTM C665-17 *Standard Specification for Mineral-Fiber Blanket Thermal Insulation for Light Frame Construction and Manufactured Housing*. ASTM International, West Conshohocken, PA, 2017.
7. ASTM C764-19 *Standard Specification for Mineral Fiber Loose-Fill Thermal Insulation*. ASTM International, West Conshohocken, PA, 2019.
8. ASTM C840-20 *Standard Specification for Application and Finishing of Gypsum Board*. ASTM International, West Conshohocken, PA, 2020.
9. ASTM C920-18 *Standard Specification for Elastomeric Joint Sealants*. ASTM International, West Conshohocken, PA, 2018.
10. ASTM C1002-20 *Standard Specification for Steel Self-Piercing Tapping Screws for Application of Gypsum Panel Products or Metal Plaster Bases to Wood Studs or Steel Studs*. ASTM International, West Conshohocken, PA, 2022.
11. ASTM C1177-17 *Standard Specification for Glass Mat Gypsum Substrate for Use as Sheathing*. ASTM International, West Conshohocken, PA, 2017.
12. ASTM C1280-18 *Standard Specification for Application of Exterior Gypsum Panel Products for Use as Sheathing*. ASTM International, West Conshohocken, PA, 2018.
13. ASTM C1396-17 *Standard Specification for Gypsum Board*. ASTM International, West Conshohocken, PA, 2017.
14. ASTM C1658-19 *Standard Specification for Glass Mat Gypsum Panels*. ASTM International, West Conshohocken, PA, 2019.
15. ASTM D2898-10 (2017) *Standard Practice for Accelerated Weathering of Fire-Retardant-Treated Wood for Fire Testing*. ASTM International, West Conshohocken, PA, 2017.
16. ASTM D3201/D3201M-20 *Standard Test Method for Hygroscopic Properties of Fire-Retardant Wood and Wood-Based Products*. ASTM International, West Conshohocken, PA, 2020.
17. ASTM D3498-19a *Standard Specification for Adhesives for Field-Gluing Wood Structural Panels (Plywood or Oriented Strand Board) to Wood Based Floor System Framing*. ASTM International, West Conshohocken, PA, 2019.
18. ASTM D5055-19e1 *Standard Specification for Establishing and Monitoring Structural Capacities of Prefabricated Wood I-Joists*. ASTM International, West Conshohocken, PA, 2019.
19. ASTM D5456-19e1 *Standard Specification for Evaluation of Structural Composite Lumber Products*. ASTM International, West Conshohocken, PA, 2019.
20. ASTM D5516-18 *Standard Test Method for Evaluating the Flexural Properties of Fire-Retardant Treated Softwood Plywood Exposed to Elevated Temperatures*. ASTM International, West Conshohocken, PA, 2018.
21. ASTM D5664-17 *Standard Test Method for Evaluating the Effects of Fire-Retardant Treatments and Elevated Temperatures on Strength Properties of Fire-Retardant Treated Lumber*. ASTM International, West Conshohocken, PA, 2017.
22. ASTM D6305-08 (2015)e1 *Standard Practice for Calculating Bending Strength Design Adjustment Factors for Fire-Retardant-Treated Plywood Roof Sheathing*. ASTM International, West Conshohocken, PA, 2015.
23. ASTM D6841-16 *Standard Practice for Calculating Design Value Treatment Adjustment Factors for Fire-Retardant-Treated Lumber*. ASTM International, West Conshohocken, PA, 2016.
24. ASTM D8223-19 *Standard Practice for Evaluation of Fire-Retardant Treated Laminated Veneer Lumber*. ASTM International, West Conshohocken, PA, 2019.

25. ASTM E84-20 *Standard Test Method for Surface Burning Characteristics of Building Materials*. ASTM International, West Conshohocken, PA, 2020.
26. ASTM E119-20 *Standard Test Methods for Fire Tests of Building Construction and Materials*. ASTM International, West Conshohocken, PA, 2020.
27. ASTM E648-19ae1 *Standard Test Method for Critical Radiant Flux of Floor-Covering Systems Using a Radiant Heat Energy Source*. ASTM International, West Conshohocken, PA, 2019.
28. ASTM E814 - 13a (2017) *Standard Test Method for Fire Tests of Penetration Firestop Systems*. ASTM International, West Conshohocken, PA, 2017.
29. ASTM E1966 – 15 (2019) *Standard Test Method for Fire-Resistive Joint Systems*. ASTM International, West Conshohocken, PA, 2019.
30. ASTM E2652 - 18 *Standard Test Method for Assessing Combustibility of Materials Using a Tube Furnace with a Cone-shaped Airflow Stabilizer, at 750°C*. ASTM International, West Conshohocken, PA, 2019.
31. ASTM E2768-11 (2018) *Standard Test Method for Extended Duration Surface Burning Characteristics of Building Materials (30 min Tunnel Test)*. ASTM International, West Conshohocken, PA, 2018.
32. ASTM F1667-18a *Standard Specification for Driven Fasteners: Nails, Spikes, and Staples*. ASTM International, West Conshohocken, PA, 2018.
33. ANSI/APA PRG 320-19: *Standard for Performance-Rated Cross-Laminated Timber*. APA – The Engineered Wood Association, Tacoma, WA, 2019.
34. ANSI/AWC NDS-2024 *National Design Specification® (NDS®) for Wood Construction*. American Wood Council, Leesburg, VA, 2023.
35. NFPA 253 *Standard Method of Test for Critical Radiant Flux of Floor Covering Systems Using a Radiant Heat Energy Source*. National Fire Protection Association, Quincy, MA, 2019.
36. NFPA 268 *Standard Test Method for Determining Ignitability of Exterior Wall Assemblies Using a Radiant Heat Energy Source*. National Fire Protection Association, Quincy, MA, 2017.
37. NFPA 285 *Standard Fire Test Method for Evaluation of Fire Propagation Characteristics of Exterior Wall Assemblies Containing Combustible Components*. National Fire Protection Association, Quincy, MA, 2019.
38. NFPA 286 *Standard Methods of Fire Tests for Evaluating Contribution of Wall and Ceiling Interior Finish to Room Fire Growth*. National Fire Protection Association, Quincy, MA, 2019.
39. PS 1-09 *Structural Plywood*. U.S. Department of Commerce. National Institute of Standards and Technology. Gaithersburg, MD, 2009.
40. PS 2-18 *Performance Standard for Wood Structural Panels*. U.S. Department of Commerce. National Institute of Standards and Technology. Gaithersburg, MD, 2018.
41. PS 20-20 *American Softwood Lumber Standard*. U.S. Department of Commerce. National Institute of Standards and Technology. Gaithersburg, MD, 2020.
42. ANSI/TPI 1-2014: *National Design Standard for Metal Plate Connected Wood Truss Construction*. Truss Plate Institute, Waldorf, MD, 2014.
43. UL 263. *Fire Tests of Building Construction and Materials*. Underwriters Laboratories Inc, Northbrook, IL, 2020.
44. UL 723: *Standard for Test for Surface Burning Characteristics of Building Materials*. Underwriters Laboratories Inc, Northbrook, IL, 2018.
45. UL 1479 *Standard for Fire Tests of Penetration Firestops*. Underwriters Laboratories Inc, Northbrook, IL, 2015.
46. UL 2079 *Tests for Fire Resistance of Building Joint Systems*. Underwriters Laboratories Inc, Northbrook, IL, 2020.
47. ALSC *Glued Lumber Policy*. American Lumber Standards Committee, Frederick, MD, 2020.

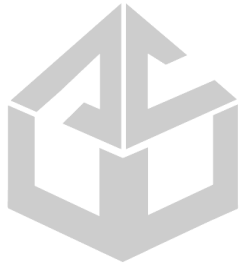

SUPPLEMENTS TO THE FIRE DESIGN SPECIFICATION

SUPPLEMENT A:

Flame Spread Performance of Wood Products Used for Interior Finish	42
Table A1 Reported Flame Spread Indices of Solid Wood Products	42
Table A2 Reported Flame Spread Indices of Wood Panels	43

SUPPLEMENT B:

Fire-Resistance-Rated Wood-Frame Wall and Floor-Ceiling Assemblies	45
Table B1 One-Hour Fire-Resistance-Rated Loadbearing Wood-Frame Wall Assemblies	45
Table B2 Two-Hour Fire-Resistance-Rated Loadbearing Wood-Frame Wall Assemblies	45
Table B3 One-Hour Fire-Resistance-Rated Wood Floor- Ceiling Assemblies	46
Table B4 Two-Hour Fire-Resistance-Rated Wood Floor/Ceiling Assemblies	47



SUPPLEMENT A: FLAME SPREAD PERFORMANCE OF WOOD PRODUCTS USED FOR INTERIOR FINISH

Table A1 Reported Flame Spread Indices of Solid Wood Products

Material ¹	ASTM E84 Flame Spread Index	Flame Spread Class	ASTM E84 Smoke Developed Index	Source ²
Alder	80	C	165	HPVA T-14189 (2013)
Aspen	105	C	45	Exova 15-002-475(C1) (2015)
Birch, Yellow	NA ⁴	C ⁴	NA	UL527 (1971)
Cedar, Alaska	40	B	140	HPVA T-15591 (2017)
Cedar, Alaska Yellow	50	B	115	HPVA T-12704 (2008)
Cedar, Eastern White	40	B	200	HPVA T-15318 (2017)
Cedar, Incense	45	B	150	HPVA T-15204 (2016)
Cedar, Port Orford	60	B	150	HPVA T-12694 (2008)
Cedar, Western Red	45	B	125	HPVA T-15172 (2016)
Cottonwood	NA ⁴	C ⁴	NA	UL527 (1971)
Cypress	75	B	200	HPVA T-14530 (2014)
Douglas-fir	70	B	80	HPVA T-14253 (2013)
Fir, Balsam	45	B	105	HPVA T-15557 (2017)
Fir, White	40	B	80	HPVA T-15088 (2016)
Gum, Red	NA ⁴	C ⁴	NA	UL527 (1971)
Hem-Fir Species Group ³	60	B	70	HPVA T-10602 (2001)
Hemlock, Eastern	35	B	175	HPVA T-15320 (2017)
Hemlock, Western	40	B	60	Exova 15-002-475(A1) (2015)
Maple (flooring)	NA ⁴	C ⁴	155	CWC FP-6 (1973)
Maple (rough sawn)	35	B	250	HPVA T-14573 (2014)
Oak, Red or White	NA ⁴	C ⁴	NA	UL527 (1971)
Pine, Eastern White	70	B	110	HPVA T-14186 (2013)
Pine, Idaho White	NA ⁴	B ⁴	125	HPVA T-592 (1974)
Pine, Jack	50	B	165	HPVA T-15556 (2017)
Pine, Lodgepole	75	B	140	HPVA T-15029 and T-15069 (2015)
Pine, Ponderosa	55	B	135	HPVA T-15067 (2016)
Pine, Red	115	C	65	Exova 15-002-475(B1) (2015)
Pine, Southern Yellow	70	B	165	HPVA T-14254 (2013)
Pine, Sugar	45	B	110	HPVA T-15068 (2016)
Pine, Western White	NA ⁴	B ⁴	NA	UL527 (1971)
Poplar, Yellow	125	C	125	HPVA T-14512 (2014)
Redwood	55	B	135	HPVA T-14185 and T-14243 (2013)
Spruce, Black	45	B	250	HPVA T-14053 (2013)
Spruce, Black (4" thick,	35	B	55	HPVA T-14054 (2013)
Spruce, Eastern Red	65	B	170	HPVA T-15034 (2015)
Spruce, Western White	45	B	120	HPVA T-15032 (2015)
Tamarack	35	B	90	HPVA T-15393 (2017)
Walnut	75	B	125	HPVA T-14526 (2014)

¹ Thickness of material tested is one-inch nominal except where indicated.

² Sources: CWC – Canadian Wood Council; Exova – Exova Warringtonfire North America; HPVA – Hardwood Plywood Veneer Association; UL – Underwriters' Laboratories. Test report numbers and year of test are indicated. Where multiple reports are cited, tabulated FSI and SDI values represent the average of values from the respective test reports.

³ The Hem-Fir Species Group represents six species: Californian Red Fir, Grand Fir, Noble Fir, Pacific Silver Fir, Western Hemlock, and White Fir. The reported flame spread index represents a product containing a mixture of these species. When lumber is from a single species refer to the specific species flame spread index.

⁴ Flame spread index cannot be directly determined from the referenced source; however, the reported Flame Spread Class is deemed to be a reasonable estimate based on changes to the analysis method of test results as reported within the referenced source.

Table A2 Reported Flame Spread Indices of Wood Panels

Material	ASTM E84 Flame Spread Index	Flame Spread Class	ASTM E84 Smoke Developed Index	Source ¹
ORIENTED STRAND BOARD (Exterior Glue) ²				
5/16"	127-138	C	155-171	APA (1985)
3/8"	100	C	95	HPVA T-15116 (2016)
7/16"	115-155	C	75-130	APA 8901-8 (1989)
15/32"	100	C	80	HPVA T-15117 (2016)
1/2"	75-172	C	109-194	APA (1985)
19/32"	175	C	95	HPVA T-14312 (2013)
23/32"	100	C	60	HPVA T-15118 (2016)
3/4"	147-158	C	111	APA (1985)
1-1/8"	110	C	115	HPVA T-15298 (2016)
SOFTWOOD PLYWOOD (Exterior Glue) ³				
1/4"	NA5	C5	55-200	UL R6829 (1973)
3/8"	NA5	C5	22-144	UL R6829 (1973)
1/2"	NA5	C5	55	UL R6829 (1973)
19/32"	95	C	50	HPVA T-14311 (2013)
5/8"	NA5	C5	50-85	UL R6829 (1973)
1/4" Douglas-fir Plywood	85	C	70	HPVA T-15293 (2016)
3/8" Douglas-fir Plywood	65	B	60	HPVA T-15295 (2016)
15/32" Douglas-fir Plywood	40	B	50	HPVA T-15114 (2016)
23/32" Douglas-fir Plywood	35	B	55	HPVA T-15294 (2016)
11/32" Southern Pine Plywood	75	B	115	HPVA T-15113 (2016)
15/32" Southern Pine Plywood	95	C	135	HPVA T-15297 (2016)
23/32" Southern Pine Plywood	65	B	175	HPVA T-15296 (2016)
HARDWOOD PLYWOOD⁴				
Ash 3/4" - Particleboard Core	135	C	80	HPVA T-9344 (1995)
Birch 1/4" - MDF Core	120	C	200	HPVA T-14750 (2015)
Birch 1/4" - Douglas Fir Veneer Core	115	C	40	HPVA T-14911 (2015)
Birch 1/4" - Fuma Veneer Core	125	C	15	HPVA T-9665 (1996)
Birch 1/4" - High Density Veneer Core	165	C	65	HPVA T-9234 (1995)
Birch 1/4" - Poplar Veneer Core	110	C	15	HPVA T-14697 (2015)
Birch 3/4" - Combination Core	90	C	120	HPVA T-14691 (2015)
Birch 3/4" - High Density Veneer Core	115	C	50	HPVA T-9317 (1995)
Birch 3/4" - Particleboard Core	125	C	100	HPVA T-9431 (1995)
Birch 3/4" - MDF Core	120	C	110	HPVA T-14917 (2015)
Birch 3/4" - Aspen Veneer Core	135	C	70	HPVA T-14700 (2015)
Birch 3/4" - Baltic Birch Veneer Core	120	C	70	HPVA T-14694 (2015)
Birch 3/4" - Douglas Fir Veneer Core	70	B	55	HPVA T-14704 (2015)
Birch 3/4" - Poplar Veneer Core	95	C	140	HPVA T-14689 (2015)
Birch 3/4" - Russian Birch Veneer Core	110	C	70	HPVA T-14764 (2015)
Mahogany 3/4" - High Density Veneer Core	105	C	90	HPVA T-9354 (1995)
Maple 1/4" - Douglas Fir Veneer Core	130	C	45	HPVA T-14910 (2015)
Maple 1/4" - Poplar Veneer Core	170	C	55	HPVA T-14695 (2015)
Maple 3/4" - Combination Core	100	C	85	HPVA T-14706 (2015)
Maple 3/4" - MDF Core	130	C	70	HPVA T-14763 (2015)
Maple 3/4" - Particleboard Core	85	C	75	HPVA T-14912 (2015)
Maple 3/4" - Aspen Veneer Core	180	C	75	HPVA T-14699 (2015)
Maple 3/4" - Baltic Birch Veneer Core	125	C	70	HPVA T-14693 (2015)

Table A2 footnotes on following page.

Table A2 Footnotes

¹ Sources: APA – American Plywood Association; DOC – US Department of Commerce; HPVA – Hardwood Plywood Veneer Association; HUD – US Department of Housing and Urban Development Manual of Acceptable Practices to the HUD Minimum Property Standards; UL – Underwriters' Laboratories. Test report numbers and year of test are indicated.

² Values reported for oriented strand board (OSB) are derived from multiple tests performed on panels comprised of a variety of strand species, including aspen, Douglas-fir southern pine, and mixed softwood species.

³ Flame spread classes and Smoke-Developed Indices reported for softwood plywood are derived from multiple tests performed on panels comprised of a variety of veneer species, including Douglas-fir, hemlock, southern pine and cedar.

⁴ Flame spread classes and Smoke-Developed Indices reported for hardwood plywood are derived from multiple tests performed on panels comprised of a variety of face veneer species, core species and adhesive systems.

⁵ Flame spread index cannot be directly determined from the referenced source; however, the reported Flame Spread Class is deemed to be a reasonable estimate based on changes to the analysis method of test results as reported within the referenced source.

SUPPLEMENT B: FIRE-RESISTANCE-RATED WOOD-FRAME WALL AND FLOOR-CEILING ASSEMBLIES

Table B1 One-Hour Fire-Resistance-Rated Loadbearing Wood-Frame Wall Assemblies

Assemblies Rated from Both Sides							
Studs	Insulation	Sheathing on Both Sides		Fasteners	Details	IBC Assembly ^a	
2x4 @ 16" o.c.	3½" mineral wool batts	5/8" Type X Gypsum Wallboard (H)		2¼" #6 Type S drywall screws @ 12" o.c.	WS4-1.1	15-1.15	
2x6 @ 16" o.c.	(none)	5/8" Type X Gypsum Wallboard (H)		2¼" #6 Type S drywall screws @ 7" o.c.	WS6-1.1	15-1.14	
2x6 @ 16" o.c.	5½" mineral wool batts	5/8" Type X Gypsum Wallboard (H)		2¼" #6 Type S drywall screws @ 12" o.c.	WS6-1.2	15-1.12	
2x6 @ 16" o.c.	R-19 fiberglass insulation	5/8" Type X Gypsum Wallboard (V)		2¼" #6 Type S drywall screws @ 12" o.c.	WS6-1.4	15-1.13	
Assemblies Rated from One Side (Fire on Interior Only)							
Studs	Insulation	Sheathing		Fasteners	Details	IBC Assembly ^a	
2x4 @ 16" o.c.	3½" mineral wool batts	I	5/8" Type X Gypsum Wallboard (H)	2¼" #6 Type S drywall screws @ 12" o.c.	WS4-1.2	16-1.1	
		E	3/8" wood structural panels (V)				
2x4 @ 16" o.c.	4 mil polyethylene 3½" mineral wool batts	I	5/8" Type X Gypsum Wallboard (V)	6d cement coated box nails @ 7" o.c.	WS4-1.3		
		E	1/2" fiberboard (V)				1½" roofing nails @ 3" edges/6" field
			3/8" hardboard shiplapped panel siding				8d galv. nails @ 4" edges/8" field
2x6 @ 16" o.c.	5½" mineral wool batts	I	5/8" Type X Gypsum Wallboard (H)	2¼" #6 Type S drywall screws @ 12" o.c.	WS6-1.3	16-1.2	
		E	7/16" wood structural panels (V)	6d common nails @ 6" edges/12" field			
2x6 @ 16" o.c.	R-19 fiberglass insulation	I	5/8" Type X Gypsum Wallboard (V)	2¼" #6 Type S drywall screws @ 7" o.c.	WS6-1.5	16-1.3	
		E	3/8" wood structural panels (V)	6d common nails @ 6" edges/12" field			
2x6 @ 24" o.c.	R-19 fiberglass insulation	I	5/8" Type X Gypsum Wallboard (V)	2¼" #6 Type S drywall screws @ 7" o.c.	WS6-1.6		
		E	15/32" wood structural panels (V)	6d common nails @ 6" edges/12" field			

H - Applied horizontally with vertical joints over studs I - Interior sheathing V - Applied vertically with vertical joints over studs E - Exterior sheathing

^a Item number of comparable assembly from IBC Table 721.1(2).

Table B2 Two-Hour Fire-Resistance-Rated Loadbearing Wood-Frame Wall Assemblies

Assemblies Rated from Both Sides						
Studs	Insulation	Sheathing on Both Sides		Fasteners	Details	IBC Assembly ^a
2x6 @ 24" o.c.	5½" mineral wool batts	B	5/8" Type X Gypsum Wallboard (H)	2¼" #6 Type S drywall screws @ 24" o.c.	WS6-2.1	15-1.16
		F	5/8" Type X Gypsum Wallboard (H)	2¼" #6 Type S drywall screws @ 8" o.c.		

H - Applied horizontally with vertical joints over studs; B - Base layer sheathing; F - Face layer sheathing

^a Item number of comparable assembly from IBC Table 721.1(2).

Table B3 One-Hour Fire-Resistance-Rated Wood Floor-Ceiling Assemblies

Wood I-Joist Assemblies							
Joists	Insulation	Furring		Ceiling Sheathing	Fasteners	Details	IBC Assembly ^a
I-joists @ 24" o.c. maximum Min. flange depth: 1-1/2" Min. flange area: 5.25 sq. in. Min. web thickness: 3/8" Min. I-joist depth: 9-1/4"	1-1/2" mineral wool batts (2.5 pcf-nominal) Resting on hat-shaped channels	Hat-shaped channels or Resilient channels	F	5/8" Type C Gypsum Wallboard (GWB)	1-1/8" Type S drywall screws spaced 12" o.c. in GWB field spaced 8" o.c. at GWB end joints (see fastening details)	WIJ-1.1	24-1.1
I-joists @ 24" o.c. maximum Min. flange depth: 1-1/2" Min. flange area: 5.25 sq. in. Min. web thickness: 7/16" Min. I-joist depth: 9-1/4"	1-1/2" mineral wool batts (2.5 pcf-nominal) Resting on resilient channels	Resilient channels	F	5/8" Type C Gypsum Wallboard (GWB)	1" Type S drywall screws spaced 12" o.c. in GWB field spaced 8" o.c. at GWB end joints (see fastening details)	WIJ-1.2	25-1.1
I-joists @ 24" o.c. maximum Min. flange depth: 1-5/16" Min. flange area: 2.25 sq. in. Min. web thickness: 3/8" Min. I-joist depth: 9-1/4"	2" mineral wool batts (3.5 pcf-nominal) Resting on 1x4 setting strips	Resilient channels	F	5/8" Type C Gypsum Wallboard (GWB)	1-1/8" Type S drywall screws spaced 7" o.c. in GWB field spaced 7" o.c. at GWB end joints (see fastening details)	WIJ-1.3	23-1.1
I-joists @ 24" o.c. maximum Min. flange depth: 1-1/2" Min. flange area: 3.45 sq. in. Min. web thickness: 3/8" Min. I-joist depth: 9-1/4"	1" mineral wool batts (6 pcf-nominal) Resting on hat-shaped channels under I-joist bottom flange	Hat-shaped channels supported by CSC clips	F	1/2" Type C Gypsum Wallboard (GWB)	1" Type S drywall screws spaced 12" o.c. in GWB field spaced 6" o.c. at GWB end joints (see fastening details)	WIJ-1.4	
I-joists @ 24" o.c. maximum Min. flange depth: 1-1/2" Min. flange area: 2.25 sq. in. Min. web thickness: 3/8" Min. I-joist depth: 9-1/4"	(none)	(none)	B	1/2" Type C Gypsum Wallboard (GWB)	1" Type S drywall screws spaced 12" o.c. in GWB field spaced 12" o.c. at GWB end joints	WIJ-1.5	
			F	1/2" Type C Gypsum Wallboard (GWB)	1-5/8" Type S drywall screws spaced 12" o.c. in GWB field spaced 8" o.c. at GWB end joints 1-1/2" Type G drywall screws spaced 8" o.c. at GWB end joints (see fastening details)		
I-joists @ 24" o.c. maximum Min. flange depth: 1-5/16" Min. flange area: 1.95 sq. in. Min. web thickness: 3/8" Min. I-joist depth: 9-1/2"	(none)	Resilient channels	B	1/2" Type X Gypsum Wallboard (GWB)	1-1/4" Type S drywall screws spaced 12" o.c. in GWB field spaced 12" o.c. at GWB end joints	WIJ-1.6	27-1.1
			F	1/2" Type X Gypsum Wallboard (GWB)	1-5/8" Type S drywall screws spaced 12" o.c. in GWB field spaced 12" o.c. at GWB end joints 1-1/2" Type G drywall screws spaced 8" o.c. at GWB end joints (see fastening details)		
I-joists @ 24" o.c. maximum Min. flange depth: 1-1/2" Min. flange area: 2.25 sq. in. Min. web thickness: 3/8" Min. I-joist depth: 9-1/2"	Fiberglass batts Resting on resilient channels	Resilient channels	B	1/2" Type X Gypsum Wallboard (GWB)	1-1/4" Type S drywall screws spaced 12" o.c. in GWB field spaced 12" o.c. at GWB end joints	WIJ-1.7	30-1.1
			F	1/2" Type X Gypsum Wallboard (GWB)	1-5/8" Type S drywall screws spaced 12" o.c. in GWB field spaced 12" o.c. at GWB end joints 1-1/2" Type G drywall screws spaced 8" o.c. at GWB end joints (see fastening details)		

B - Base layer sheathing; F - Face layer sheathing

^a Item number of comparable assembly from IBC Table 721.1(3).

Table B4 Two-Hour Fire-Resistance-Rated Wood Floor/Ceiling Assemblies

Wood I-Joist Assemblies							
Joists	Insulation	Furring	Ceiling Sheathing		Fasteners	Details	IBC Assembly ^a
I-joists @ 24" o.c. maximum Min. flange depth: 1-1/2" Min. flange area: 2.25 sq. in. Min. web thickness: 3/8" Min. I-joist depth: 9-1/4"	3-1/2" fiberglass insulation Supported by stay wires spaced 12" o.c.	(none)	B	5/8" Type C Gypsum Wallboard (GWB)	1-5/8" Type S drywall screws spaced 12" o.c. in GWB field spaced 12" o.c. at GWB end joints	WIJ-2.1	28-1.1
		Hat-shaped channels or Resilient channels	M	5/8" Type C Gypsum Wallboard (GWB)	1" Type S drywall screws spaced 12" o.c. in GWB field spaced 12" o.c. at GWB end joints		
			F	5/8" Type C Gypsum Wallboard (GWB)	1-5/8" Type S drywall screws spaced 8" o.c. in GWB field spaced 8" o.c. at GWB end joints (see fastening details)		
B - Base layer sheathing (direct attached); M - Middle layer sheathing; F - Face layer sheathing							

^a Item number of comparable assembly from IBC Table 721.1(3).

WS4-1.1 One Hour Fire-Resistance-Rated Wood-Frame Wall Assembly

2x4 Wood Stud Wall – 100% Design Load – ASTM E 119/NFPA 251

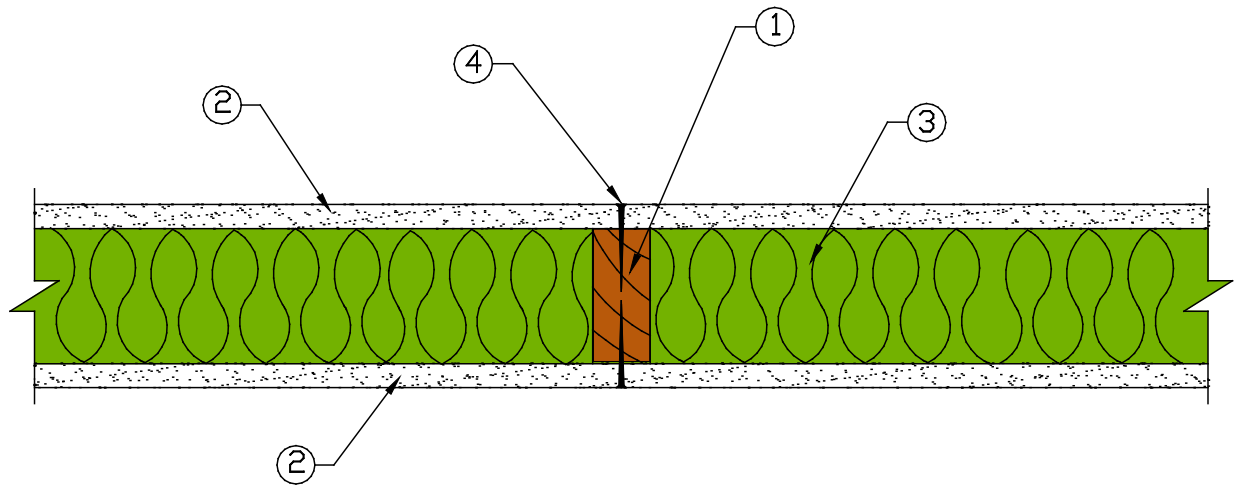

1. **Framing:** Nominal 2x4 wood studs, spaced 16 in. o.c., double top plates, single bottom plate
2. **Sheathing:** 5/8 in. Type X gypsum wallboard, 4 ft. wide, applied horizontally. Horizontal joints are unblocked. Horizontal application of wallboard represents the direction of least fire resistance as opposed to vertical application.
3. **Insulation:** 3-1/2-inch-thick mineral wool insulation (2.5 pcf, nominal)
4. **Fasteners:** 2-1/4 in. #6 Type S drywall screws, spaced 12 in. o.c.
5. **Joints and Fastener Heads:** Wallboard joints covered with paper tape and joint compound, fastener heads covered with joint compound

Tests conducted at the Fire Test Laboratory of National Gypsum Research Center

Test No: WP-1248 (Fire Endurance) March 29, 2000
WP-1246 (Hose Stream) March 09, 2000

Third Party Witness: Intertek Testing Services
Report J20-06170.1

This assembly was tested at 100% design load, calculated in accordance with the 2018 *National Design Specification*[®] (*NDS*) for Wood Construction. The authority having jurisdiction should be consulted to assure acceptance of this report.

WS4-1.2 One-Hour Fire-Resistance-Rated Wood-Frame Wall Assembly (Rated from gypsum wallboard side)

2x4 Wood Stud Wall – 100% Design Load – ASTM E 119/NFPA 251

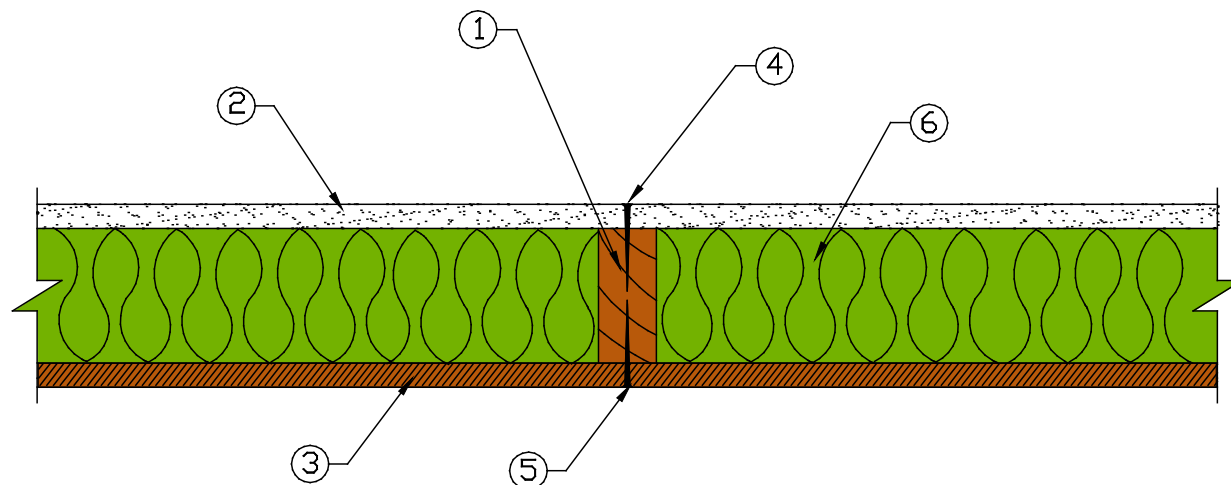

- 1 **Framing:** Nominal 2x4 wood studs, spaced 16 in. o.c., double top plates, single bottom plate
2. **Interior Sheathing:** 5/8 in. Type X gypsum wallboard, 4 ft. wide, applied horizontally. Horizontal joints are unblocked. Horizontal application of wallboard represents the direction of least fire resistance as opposed to vertical application.
3. **Exterior Sheathing:** Minimum 3/8 in. wood structural panels (oriented strand board), applied vertically, horizontal joints blocked
4. **Gypsum Fasteners:** 2-1/4 in. #6 Type S drywall screws, spaced 12 in. o.c.
5. **Panel Fasteners:** 6d common nails (bright) - 12 in. o.c. in the field, 6 in. o.c. panel edges
6. **Insulation:** 3-1/2-inch-thick mineral wool insulation (2.5 pcf, nominal)
7. **Joints and Fastener Heads:** Wallboard joints covered with paper tape and joint compound, fastener heads covered with joint compound

Tests conducted at the Fire Test Laboratory of National Gypsum Research Center

Test No: WP-1261 (Fire Endurance & Hose Stream) November 1, 2000

Third Party Witness: Intertek Testing Services

Report J20-006170.2

This assembly was tested at 100% design load, calculated in accordance with the 2018 *National Design Specification*[®] (NDS) for Wood Construction. The authority having jurisdiction should be consulted to assure acceptance of this report.

**WS4-1.3 One-Hour Fire-Resistance-Rated Wood-Frame Wall Assembly
(Rated from gypsum wallboard side)**

2x4 Wood Stud Wall – 78% Design Load – ASTM E 119/NFPA 251

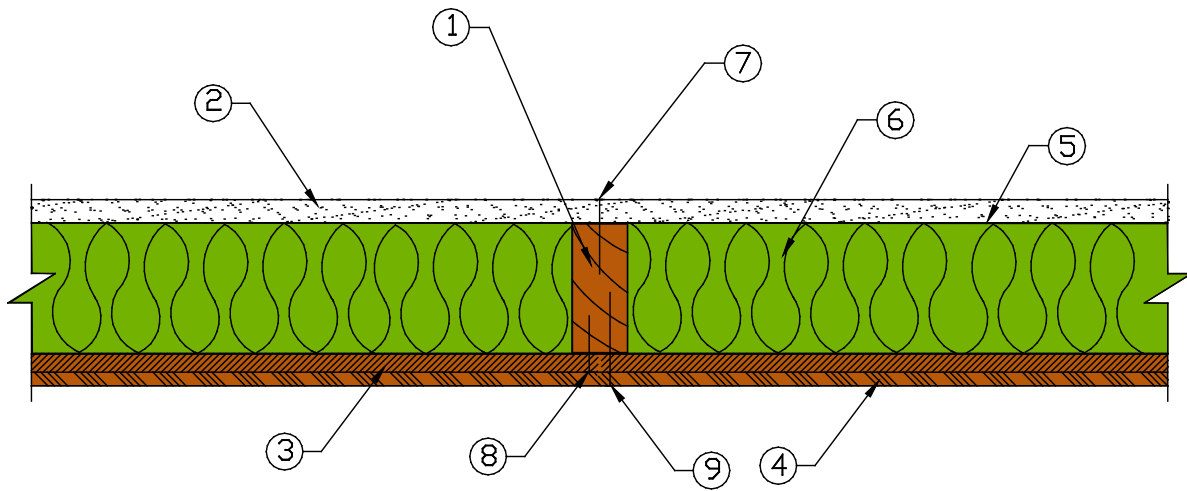

1. **Framing:** Nominal 2x4 wood studs, spaced 16 in. o.c., double top plates, single bottom plate
2. **Interior Sheathing:** 5/8 in. Type X gypsum wallboard, 4 ft. wide, applied vertically, unblocked
3. **Exterior Sheathing:** Minimum 1/2 in. fiberboard sheathing. Alternate construction - minimum 1/2 in. lumber siding or 1/2 in. wood based sheathing.
4. **Exterior Siding:** 3/8 in. hardboard shiplap edge panel siding. Alternate construction - lumber, wood based, vinyl, or aluminum siding.
5. **Vapor Barrier:** 4-mil polyethylene sheeting
6. **Insulation:** 3-1/2-inch-thick mineral wool insulation (2.5 pcf, nominal)
7. **Gypsum Fasteners:** 6d cement coated box nails spaced 7 in. o.c.
8. **Fiberboard Fasteners:** 1-1/2 in. galvanized roofing nails - 6 in. o.c. in the field, 3 in. o.c. panel edges
9. **Hardboard Fasteners:** 8d galvanized nails - 8 in. o.c. in the field, 4 in. o.c. panel edges
10. **Joints and Fastener Heads:** Wallboard joints covered with paper tape and joint compound, fastener heads covered with joint compound

Tests conducted at the Gold Bond Building Products Fire Testing Laboratory

Test No: WP-584 (Fire Endurance & Hose Stream) March 19, 1981

Third Party Witness: Warnock Hersey International, Inc.
Report WHI-690-003

This assembly was tested at 78% design load using an l/d of 33, calculated in accordance with the 2018 *National Design Specification*[®] (*NDS*) for Wood Construction. The authority having jurisdiction should be consulted to assure acceptance of this report.

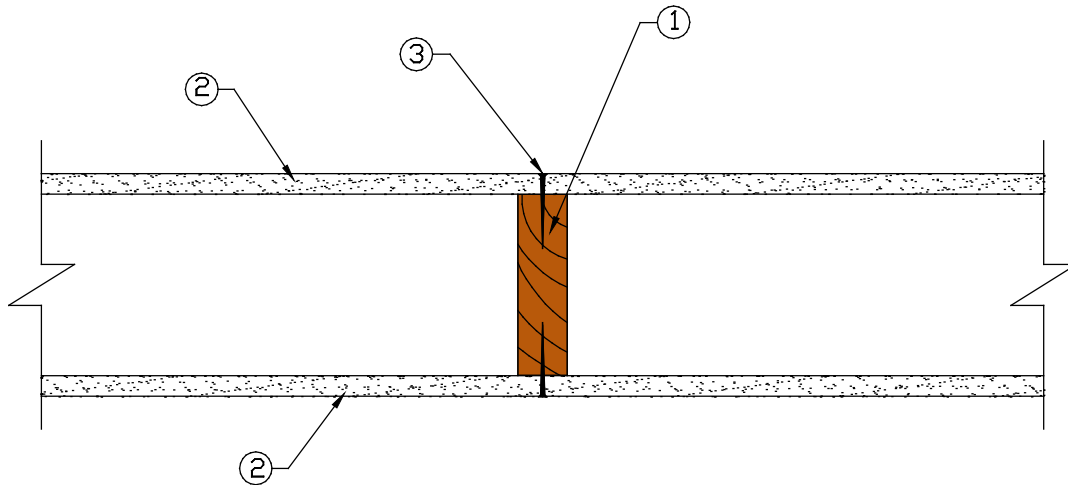
WS6-1.1 One-Hour Fire-Resistance-Rated Wood-Frame Wall Assembly**2x6 Wood Stud Wall – 100% Design Load – ASTM E 119/NFPA 251**

1. **Framing:** Nominal 2x6 wood studs, spaced 16 in. o.c., double top plates, single bottom plate
2. **Sheathing:** 5/8 in. Type X gypsum wallboard, 4 ft. wide, applied horizontally. Horizontal joints are unblocked. Horizontal application of wallboard represents the direction of least fire resistance as opposed to vertical application.
3. **Fasteners:** 2-1/4 in. #6 Type S drywall screws, spaced 7 in. o.c.
4. **Joints and Fastener Heads:** Wallboard joints covered with paper tape and joint compound, fastener heads covered with joint compound

Tests conducted at the Fire Test Laboratory of National Gypsum Research Center

Test No:	WP-1232 (Fire Endurance)	September 16, 1999
	WP-1234 (Hose Stream)	September 27, 1999

Third Party Witness: Intertek Testing Services
Report J99-22441.2

This assembly was tested at 100% design load, calculated in accordance with the 2018 *National Design Specification*[®] (*NDS*) for Wood Construction. The authority having jurisdiction should be consulted to assure acceptance of this report.

WS6-1.2 One-Hour Fire-Resistance-Rated Wood-Frame Wall Assembly

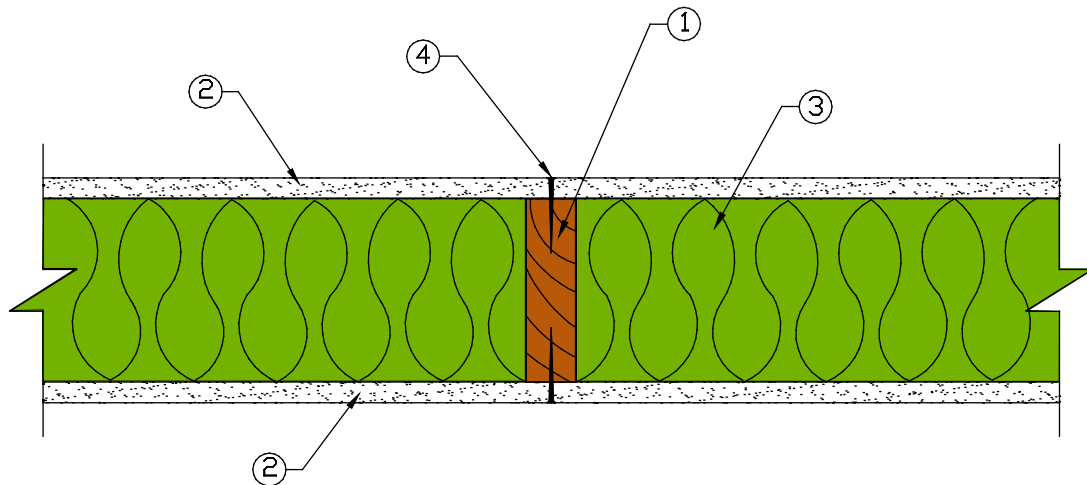
2x6 Wood Stud Wall – 100% Design Load – ASTM E 119/NFPA 251

- 1. Framing:** Nominal 2x6 wood studs, spaced 16 in. o.c., double top plates, single bottom plate
- 2. Sheathing:** 5/8 in. Type X gypsum wallboard, 4 ft. wide, applied horizontally. Horizontal joints are unblocked. Horizontal application of wallboard represents the direction of least fire resistance as opposed to vertical application.
- 3. Insulation:** 5-1/2-inch-thick mineral wool insulation (2.5 pcf, nominal)
- 4. Fasteners:** 2-1/4 in. #6 Type S drywall screws, spaced 12 in. o.c.
- 5. Joints and Fastener Heads:** Wallboard joints covered with paper tape and joint compound, fastener heads covered with joint compound

Tests conducted at the Fire Test Laboratory of National Gypsum Research Center

Test No: WP-1231 (Fire Endurance) September 14, 1999
 WP-1230 (Hose Stream) August 30, 1999

Third Party Witness: Intertek Testing Services
 Report J99-22441.1

This assembly was tested at 100% design load, calculated in accordance with the 2018 *National Design Specification*[®] (*NDS*) for Wood Construction. The authority having jurisdiction should be consulted to assure acceptance of this report.

WS6-1.3 One-Hour Fire-Resistance-Rated Wood-Frame Wall Assembly (Rated from gypsum wallboard side)

2x6 Wood Stud Wall – 100% Design Load – ASTM E 119/NFPA 251

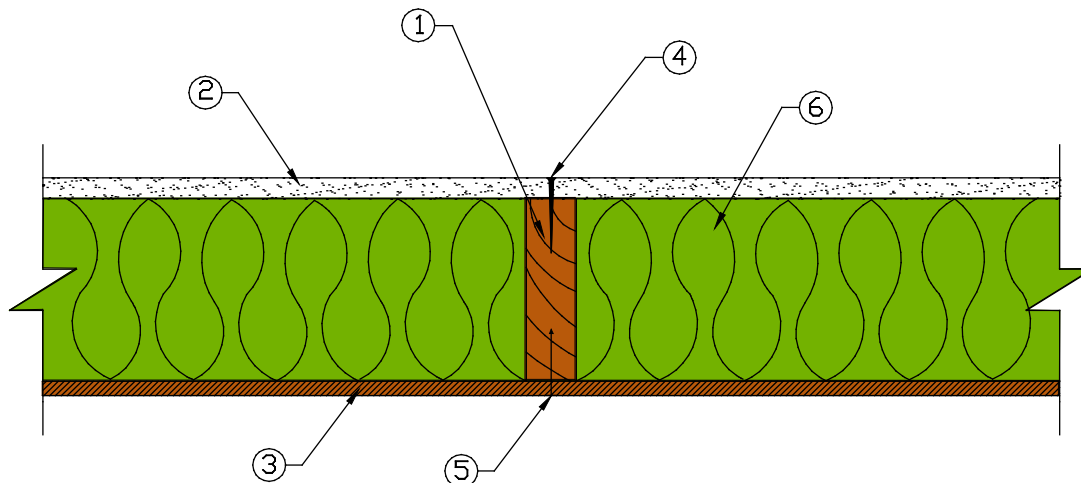

1. **Framing:** Nominal 2x6 wood studs, spaced 16 in. o.c., double top plates, single bottom plate
2. **Interior Sheathing:** 5/8 in. Type X gypsum wallboard, 4 ft. wide, applied horizontally. Horizontal joints are unblocked. Horizontal application of wallboard represents the direction of least fire resistance as opposed to vertical application.
3. **Exterior Sheathing:** Minimum 7/16 in. wood structural panels (oriented strand board), applied vertically, horizontal joints blocked
4. **Gypsum Fasteners:** 2-1/4 in. #6 Type S drywall screws, spaced 12 in. o.c.
5. **Panel Fasteners:** 6d common nails (bright) - 12 in. o.c. in the field, 6 in. o.c. panel edges
6. **Insulation:** 5-1/2-inch-thick mineral wool insulation (2.5 pcf, nominal)
7. **Joints and Fastener Heads:** Wallboard joints covered with paper tape and joint compound, fastener heads covered with joint compound

Tests conducted at the Fire Test Laboratory of National Gypsum Research Center

Test No: WP-1244 (Fire Endurance & Hose Stream) February 25, 2000

Third Party Witness: Intertek Testing Services
Report J99-27259.

This assembly was tested at 100% design load, calculated in accordance with the 2018 *National Design Specification*[®] (NDS) for Wood Construction. The authority having jurisdiction should be consulted to assure acceptance of this report.

WS6-1.4 One-Hour Fire-Resistance-Rated Wood-Frame Wall Assembly

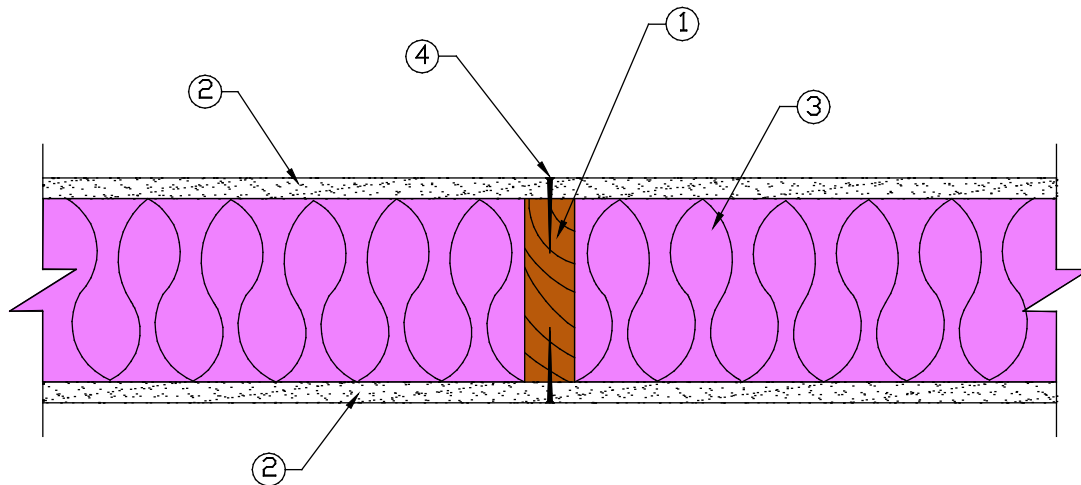
2x6 Wood Stud Wall – 100% Design Load – ASTM E 119/NFPA 251

- 1. Framing:** Nominal 2x6 wood studs, spaced 16 in. o.c., double top plates, single bottom plate
- 2. Sheathing:** 5/8 in. Type X gypsum wallboard, 4 ft. wide, applied vertically. All panel edges backed by framing or blocking.
- 3. Insulation:** R-19 fiberglass insulation
- 4. Fasteners:** 2-1/4 in. #6 Type S drywall screws, spaced 12 in. o.c.
- 5. Joints and Fastener Heads:** Wallboard joints covered with paper tape and joint compound, fastener heads covered with joint compound

Tests conducted at NGC Testing Services

Test No: WP-1346 (Fire Endurance) August 22, 2003
 WP-1351 (Hose Stream) September 17, 2003

Third Party Witness: NGC Testing Services

This assembly was tested at 100% design load, calculated in accordance with the 2018 *National Design Specification*[®] (*NDS*) for Wood Construction. The authority having jurisdiction should be consulted to assure acceptance of this report.

WS6-1.5 One-Hour Fire-Resistance-Rated Wood-Frame Wall Assembly (Rated from gypsum wallboard side)

2x6 Wood Stud Wall – 100% Design Load – ASTM E 119/NFPA 251

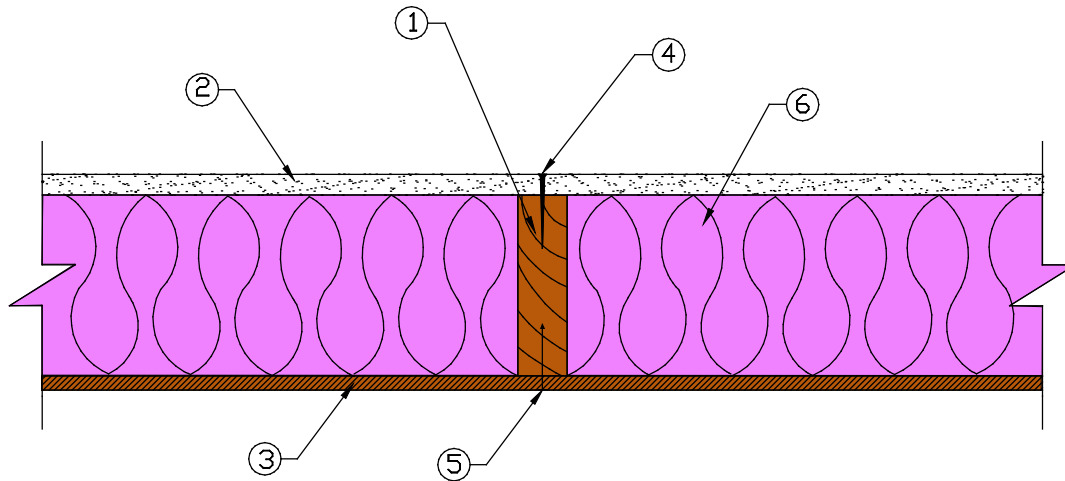

1. **Framing:** Nominal 2x6 wood studs, spaced 16 in. o.c., double top plates, single bottom plate
2. **Interior Sheathing:** 5/8 in. Type X gypsum wallboard, 4 ft. wide, applied vertically. All panel edges backed by framing or blocking.
3. **Exterior Sheathing:** Minimum 3/8 in. wood structural panels (oriented strand board), applied vertically, horizontal joints blocked
4. **Gypsum Fasteners:** 2-1/4 in. #6 Type S drywall screws, spaced 7 in. o.c.
5. **Panel Fasteners:** 6d common nails (bright) - 12 in. o.c. in the field, 6 in. o.c. panel edges
6. **Insulation:** R-19 fiberglass insulation
7. **Joints and Fastener Heads:** Wallboard joints covered with paper tape and joint compound, fastener heads covered with joint compound

Tests conducted at the NGC Testing Services

Test No: WP-1408 (Fire Endurance & Hose Stream) August 13, 2004

Third Party Witness: NGC Testing Services

This assembly was tested at 100% design load, calculated in accordance with the 2018 *National Design Specification*[®] (*NDS*) for Wood Construction. The authority having jurisdiction should be consulted to assure acceptance of this report.

**WS6-1.6 One-Hour Fire-Resistance-Rated Wood-Frame Wall Assembly
(Rated from gypsum wallboard side)**

2x6 Wood Stud Wall – 100% Design Load – ASTM E 119/NFPA 251

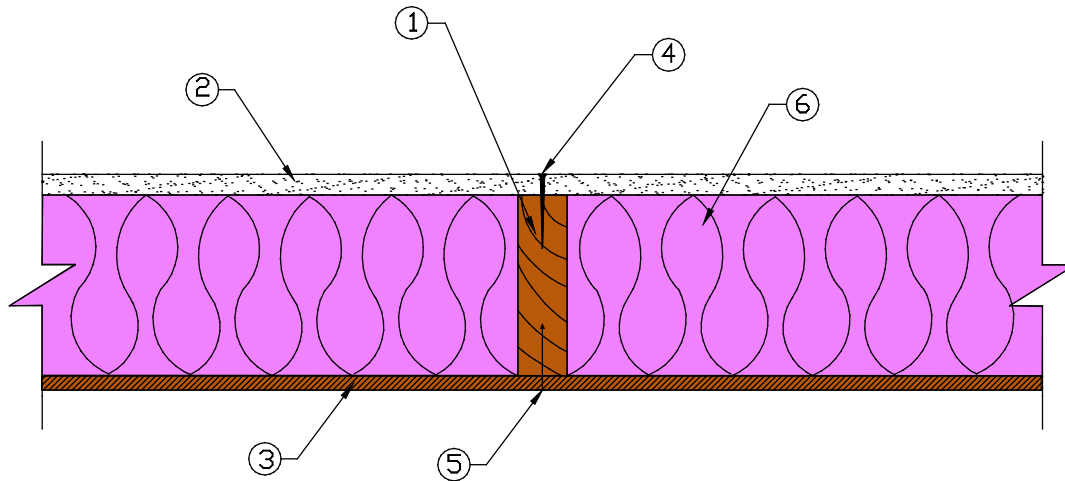

1. **Framing:** Nominal 2x6 wood studs, spaced 24 in. o.c., double top plates, single bottom plate
2. **Interior Sheathing:** 5/8 in. Type X gypsum wallboard, 4 ft. wide, applied vertically. All panel edges backed by framing or blocking.
3. **Exterior Sheathing:** Minimum 15/32 in. wood structural panels, applied vertically, horizontal joints blocked
4. **Gypsum Fasteners:** 2-1/4 in. #6 Type S drywall screws, spaced 7 in. o.c.
5. **Panel Fasteners:** 6d common nails (bright) - 12 in. o.c. in the field, 6 in. o.c. panel edges
6. **Insulation:** minimum R-19 fiberglass insulation
7. **Joints and Fastener Heads:** Wallboard joints covered with paper tape and joint compound, fastener heads covered with joint compound

Tests conducted at Western Fire Center

Test No: WFCi Report #18090r1 (Fire Endurance & Hose Stream)

February 22, 2019

Third Party Witness: Western Fire Center, Inc.

This assembly was tested at 100% design load, calculated in accordance with the 2018 *National Design Specification*[®] (*NDS*) for Wood Construction. The authority having jurisdiction should be consulted to assure acceptance of this report.

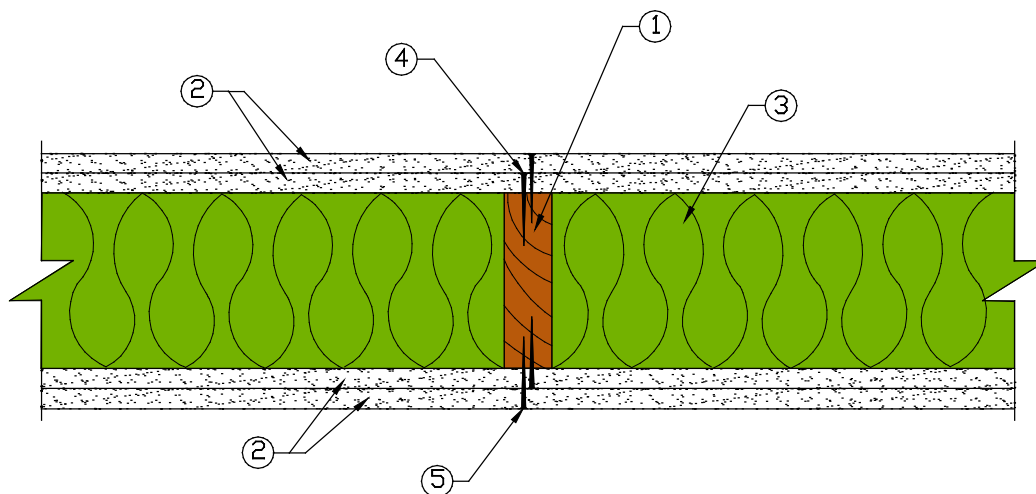
WS6-2.1 Two-Hour Fire-Resistance-Rated Wood-Frame Wall Assembly**2x6 Wood Stud Wall – 100% Design Load – ASTM E 119/NFPA 251**

1. **Framing:** Nominal 2x6 wood studs, spaced 24 in. o.c., double top plates, single bottom plate.
2. **Sheathing:** Base Layer - 5/8 in. Type X gypsum wallboard, 4 ft. wide, applied horizontally, joints staggered on opposite sides of the wall.
3. **Face Layer:** 5/8 in. Type X gypsum wallboard, 4 ft. wide, applied horizontally, joints staggered with base layer. Horizontal joints are unblocked. Horizontal application of wallboard represents the direction of least fire resistance as opposed to vertical application.
4. **Insulation:** 5-1/2-inch-thick mineral wool insulation (2.5 pcf, nominal)
5. **Gypsum Fasteners:** Base Layer - 2-1/4 in. #6 Type S drywall screws, spaced 24 in. o.c.
6. **Gypsum Fasteners:** Face Layer - 2-1/4 in. #6 Type S drywall screws, spaced 8 in. o.c.
7. **Joints and Fastener Heads:** Wallboard joints covered with paper tape and joint compound, fastener heads covered with joint compound

Tests conducted at the Fire Test Laboratory of National Gypsum Research Center

Test No:	WP-1262 (Fire Endurance)	November 3, 2000
	WP-1268 (Hose Stream)	December 8, 2000

Third Party Witness: Intertek Testing Services
Report J20-006170.3

This assembly was tested at 100% design load, calculated in accordance with the 2018 *National Design Specification*[®] (*NDS*) for Wood Construction. The authority having jurisdiction should be consulted to assure acceptance of this report.

WIJ-1.1 One-Hour Fire-Resistance-Rated Ceiling Assembly

Floor^a/Ceiling - 100% Design Load - 1 Hour Rating - ASTM E 119 / NFPA 251

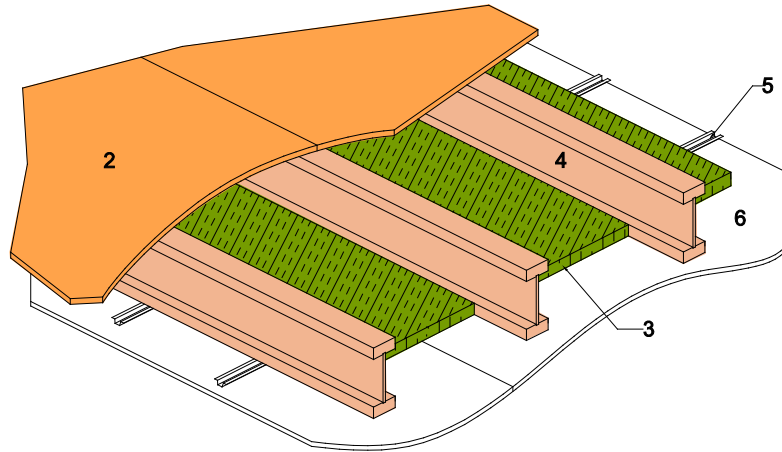

1. **Floor Topping (optional, not shown):** Gypsum concrete, lightweight or normal concrete topping.
2. **Floor Sheathing:** Minimum 23/32-inch-thick tongue-and-groove wood sheathing (Exposure 1). Installed per code requirements with minimum 8d common nails and glued to joist top flanges with AFG-01 construction adhesive.
3. **Insulation:** Minimum 1-1/2-inch-thick mineral wool batt insulation – 2.5 pcf (nominal), supported by furring channels.
4. **Structural Members:** Wood I-joists spaced a maximum of 24 inches on center. See ASTM D 5055 for qualification requirements. Additional requirements are as follows:
 - Minimum I-joist flange depth: 1-1/2 inches
 - Minimum I-joist web thickness: 3/8 inch
 - Minimum I-joist flange area: 5.25 inches²
 - Minimum I-joist depth: 9-1/4 inches
5. **Furring Channels:** Minimum 0.026-inch-thick galvanized steel hat-shaped furring channels, attached perpendicular to I-joists using 1⁵/₈-inch-long drywall screws. Furring channels spaced 16 inches on center and doubled at each wallboard end joint extending to the next joist. Based on ASTM E2032, minimum 0.019-inch-thick galvanized steel resilient channels may be used in lieu of hat-shaped furring channels if installed at the same spacing and attached in the same manner. In order to achieve the sound ratings given below, resilient channels must be used in lieu of hat-shaped furring channels.
6. **Gypsum Wallboard:** Minimum 5/8-inch-thick Type C gypsum wallboard installed with long dimension perpendicular to furring channels and fastened to each channel with minimum 1-1/8-inch-long Type S drywall screws. Fasteners spaced 12 inches on center in the field of the wallboard, 8 inches on center at wallboard end joints, and 3/4 inches from panel edges and ends. End joints of wallboard staggered.
7. **Finish System (not shown):** Face layer joints covered with tape and coated with joint compound. Screw heads covered with joint compound.

Fire Test conducted at Gold Bond Building Products Research Center February 9, 1990

Third Party Witness: Warnock Hersey International, Inc. Report No: WHI-651-0311.1

STC and IIC Sound Ratings (with Resilient Channels)

Joist/RC Spacing ^a	Without Gypsum Concrete				With 1" Gypsum Concrete			
	Cushioned Vinyl		Carpet and Pad		Cushioned Vinyl		Carpet and Pad	
	STC	IIC	STC	IIC	STC	IIC	STC	IIC
24"o.c./16"o.c.	48 (51) ^b	42 (43) ^b	48 (51) ^b	61 (63) ^b	63 (65) ^b	50 (52) ^b	63 (65) ^b	65 (67) ^b
16"o.c./16"o.c.	44 (46) ^b	37 (39) ^b	44 (46) ^b	60 (61) ^b	56 (57) ^b	46 (47) ^b	56 (57) ^b	58 (59) ^b

^a This assembly may also be used in a fire-rated roof/ceiling application, but only when constructed exactly as described.

^b STC and IIC values established by engineering analysis using the AWC Technical Report 15 (TR15) model, assuming 1.5"-thick mineral wool batt insulation (values in parentheses assume 3.5"-thick mineral wool batt) and resilient channels at 16" o.c.

^c STC and IIC values for assemblies with a joist spacing of 16" o.c. may be used for assemblies with joist spacings between 16" o.c. and 24" o.c.

WIJ-1.2 One-Hour Fire-Resistance-Rated Ceiling Assembly

Floor^a/Ceiling - 100% Design Load - 1 Hour Rating - ASTM E 119 / NFPA 251

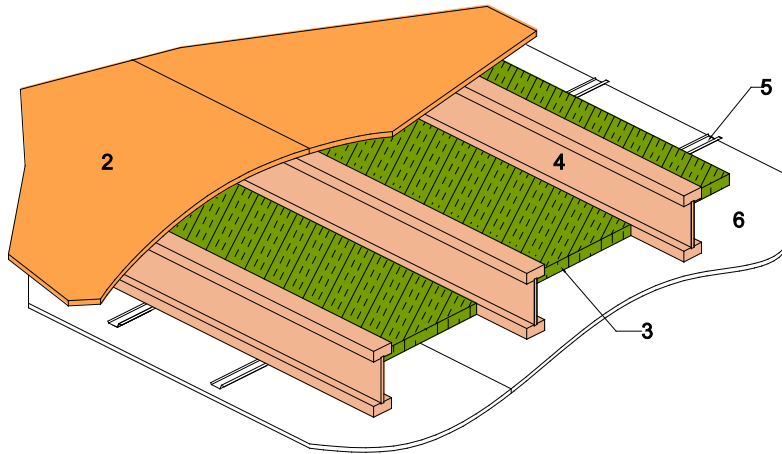

1. **Floor Topping (optional, not shown):** Gypsum concrete, lightweight or normal concrete topping.
2. **Floor Sheathing:** Minimum 23/32-inch-thick tongue-and-groove wood sheathing (Exposure 1). Installed per code requirements with minimum 8d common nails and glued to joist top flanges with AFG-01 construction adhesive.
3. **Insulation:** Minimum 1-1/2-inch-thick mineral wool batt insulation – 2.5 pcf (nominal), supported by resilient channels.
4. **Structural Members:** Wood I-joists spaced a maximum of 24 inches on center. See ASTM D 5055 for qualification requirements. Additional requirements are as follows:
 - Minimum I-joist flange depth: 1-1/2 inches
 - Minimum I-joist web thickness: 7/16 inch
 - Minimum I-joist flange area: 5.25 inches²
 - Minimum I-joist depth: 9-1/4 inches
5. **Resilient Channels:** Minimum 0.019-inch-thick galvanized steel resilient channels, attached perpendicular to I-joists using 1-5/8-inch-long drywall screws. Resilient channels spaced 16 inches on center and doubled at each wallboard end joint extending to the next joist.
6. **Gypsum Wallboard:** Minimum 5/8-inch-thick Type C gypsum wallboard installed with long dimension perpendicular to resilient channels and fastened to each channel with minimum 1-inch-long Type S drywall screws. Fasteners spaced 12 inches on center in the field of the wallboard, 8 inches on center at wallboard end joints, and 3/4 inches from panel edges and ends. End joints of wallboard staggered.
7. **Finish System (not shown):** Face layer joints covered with tape and coated with joint compound. Screw heads covered with joint compound.

Fire Test conducted at Gold Bond Building Products Research Center June 19, 1984

Third Party Witness: Warnock Hersey International, Inc. Report No: WHI-694-0159

STC and IIC Sound Ratings								
Joist/RC Spacing ^c	Without Gypsum Concrete				With 1" Gypsum Concrete			
	Cushioned Vinyl		Carpet and Pad		Cushioned Vinyl		Carpet and Pad	
	STC	IIC	STC	IIC	STC	IIC	STC	IIC
24"o.c./16"o.c.	48 (51) ^b	42 (43) ^b	48 (51) ^b	61 (63) ^b	63 (65) ^b	50 (52) ^b	63 (65) ^b	65 (67) ^b
16"o.c./16"o.c.	44 (46) ^b	37 (39) ^b	44 (46) ^b	60 (61) ^b	56 (57) ^b	46 (47) ^b	56 (57) ^b	58 (59) ^b

^a This assembly may also be used in a fire-rated roof/ceiling application, but only when constructed exactly as described.

^b STC and IIC values established by engineering analysis using the AWC Technical Report 15 (TR15) model, assuming 1.5"-thick mineral wool batt insulation (values in parentheses assume 3.5"-thick mineral wool batt).

^c STC and IIC values for assemblies with a joist spacing of 16"o.c. may be used for assemblies with joist spacings between 16"o.c. and 24"o.c.

WIJ-1.3 One-Hour Fire-Resistance-Rated Ceiling Assembly

Floor^a/Ceiling - 100% Design Load - 1 Hour Rating - ASTM E 119 / NFPA 251

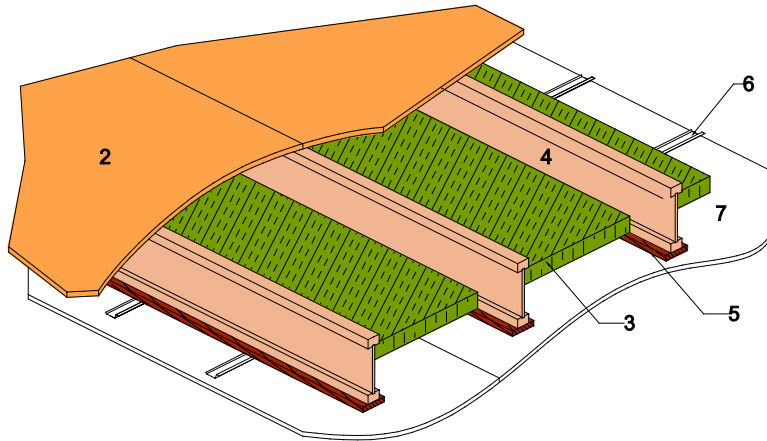

1. **Floor Topping (optional, not shown):** Gypsum concrete, lightweight or normal concrete topping.
2. **Floor Sheathing:** Minimum 23/32-inch-thick tongue-and-groove wood sheathing (Exposure 1). Installed per code requirements.
3. **Insulation:** Minimum 2-inch-thick mineral wool batt insulation – 3.5 pcf (nominal), supported by setting strip edges, friction-fitted between the sides of the I-joist flanges.
4. **Structural Members:** Wood I-joists spaced a maximum of 24 inches on center. See ASTM D 5055 for qualification requirements. Additional requirements are as follows:
 - Minimum I-joist flange depth: 1-5/16 inches
 - Minimum I-joist web thickness: 3/8 inch
 - Minimum I-joist flange area: 2.25 inches²
 - Minimum I-joist depth: 9-1/4 inches
5. **Setting Strips:** Minimum 1x4 (nominal) wood setting strips attached with 1-1/2-inch-long drywall screws at 24 inches on center along the bottom flange of I-joist creating a ledge to support insulation.
6. **Resilient Channels:** Minimum 0.019-inch-thick galvanized steel resilient channels, attached perpendicular to I-joists using 1-7/8-inch-long drywall screws. Resilient channels spaced 16 inches on center and doubled at each wallboard end joint extending to the next joist.
7. **Gypsum Wallboard:** Minimum 5/8-inch-thick Type C gypsum wallboard installed with long dimension perpendicular to resilient channels and fastened to each channel with minimum 1-1/8-inch-long Type S drywall screws. Fasteners spaced 7 inches on center and 3/4 inches from panel edges and ends. End joints of wallboard staggered.
8. **Finish System (not shown):** Face layer joints covered with tape and coated with joint compound. Screw heads covered with joint compound.

Fire Test conducted at National Gypsum Testing Services, Inc. September 28, 2001

Third Party Witness: Underwriter’s Laboratories, Inc. Report No: NC3369

STC and IIC Sound Ratings								
Joist/RC Spacing ^a	Without Gypsum Concrete				With 1" Gypsum Concrete			
	Cushioned Vinyl		Carpet and Pad		Cushioned Vinyl		Carpet and Pad	
	STC	IIC	STC	IIC	STC	IIC	STC	IIC
24"o.c./16"o.c.	50 (51) ^b	43 (43) ^b	52	66	63 (65) ^b	51 (52) ^b	63 (65) ^b	67 (67) ^b
16"o.c./16"o.c.	45 (46) ^b	38 (39) ^b	45 (46) ^b	60 (61) ^b	57 (57) ^b	46 (47) ^b	57 (57) ^b	59 (59) ^b

^a This assembly may also be used in a fire-rated roof/ceiling application, but only when constructed exactly as described.

^b STC and IIC values established by engineering analysis using the AWC Technical Report 15 (TR15) model, assuming 2"-thick mineral wool batt insulation (values in parentheses assume 3.5"-thick mineral wool batt) and neglecting the influence (if any) of the setting strips.

^c STC and IIC values for assemblies with a joist spacing of 16"o.c. may be used for assemblies with joist spacings between 16"o.c. and 24"o.c.

WIJ-1.4 One-Hour Fire-Resistance-Rated Ceiling Assembly

Floor^a/Ceiling - 100% Design Load - 1 Hour Rating - ASTM E 119 / NFPA 251

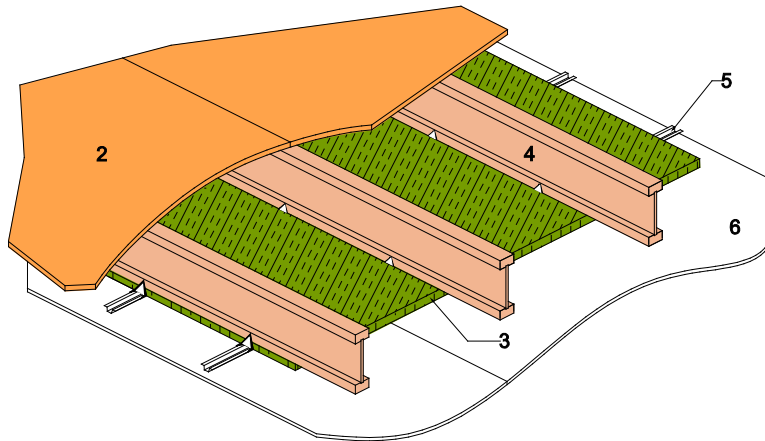

1. **Floor Topping (optional, not shown):** Gypsum concrete, lightweight or normal concrete topping.
2. **Floor Sheathing:** Minimum 23/32-inch-thick tongue-and-groove wood sheathing (Exposure 1). Installed per code requirements with minimum 8d common nails.
3. **Insulation:** Minimum 1-inch-thick mineral wool batt insulation – 6 pcf (nominal), with width equal to the on-center spacing of the I-joists. Batts installed on top of furring channels and under bottom flange of I-joists with the sides butted against support clips. Abutted ends of batts centered over furring channels with batts tightly butted at all joints.
4. **Structural Members:** Wood I-joists spaced a maximum of 24 inches on center. See ASTM D 5055 for qualification requirements. Additional requirements are as follows:
 - Minimum I-joist flange depth: 1-1/2 inches
 - Minimum I-joist web thickness: 3/8 inch
 - Minimum I-joist flange area: 3.45 inches²
 - Minimum I-joist depth: 9-1/4 inches
5. **Furring Channels:** Minimum 0.019-inch-thick galvanized steel hat-shaped furring channels, attached perpendicular to I-joists spaced 24 inches on center. At channel splices, adjacent pieces overlapped a minimum of 6 inches and tied with a double strand of No. 18 gage galvanized steel wire at each end of the overlap. Channels secured to I-joists with Simpson Type CSC support clips at each intersection with the I-joists. Clips nailed to the side of I-joist bottom flange with one 1-1/2-inch-long No. 11 gage nail. A row of furring channel located on each side of wallboard end joints and spaced 2.25 inches from the end joint (4.5 inches on center).
6. **Gypsum Wallboard:** Minimum 1/2-inch-thick Type C gypsum wallboard. Wallboard installed with long dimension perpendicular to furring channels and fastened to each channel with minimum 1-inch-long Type S drywall screws. Fasteners spaced 12 inches on center in the field of the wallboard, 6 inches on center at wallboard end joints, and 3/4 inches from panel edges and ends. End joints of wallboard staggered. For staggered wallboard end joints, furring channels extend a minimum of 6 inches beyond each end of the joint.
7. **Finish System (not shown):** Face layer joints covered with tape and coated with joint compound. Screw heads covered with joint compound.

Fire Test conducted at Underwriter’s Laboratories, Inc. May 11, 1983

Third Party Witness: Underwriter’s Laboratories, Inc. Report No: UL R10371-1

STC and IIC Sound Ratings ^b								
Joist/RC Spacing	Without Gypsum Concrete				With 3/4" Gypsum Concrete			
	Cushioned Vinyl		Carpet and Pad		Cushioned Vinyl		Carpet and Pad	
	STC	IIC	STC	IIC	STC	IIC	STC	IIC
24"o.c./24"o.c.	-	-	46	68	51	47	50	73

^a This assembly may also be used in a fire-rated roof/ceiling application, but only when constructed exactly as described.

^b Tabulated STC and IIC sound ratings are based tests of assemblies having 5/8-inch-thick gypsum wallboard.

WIJ-1.5 One-Hour Fire-Resistance-Rated Ceiling Assembly

Floor^a/Ceiling - 100% Design Load - 1 Hour Rating - ASTM E 119 / NFPA 251

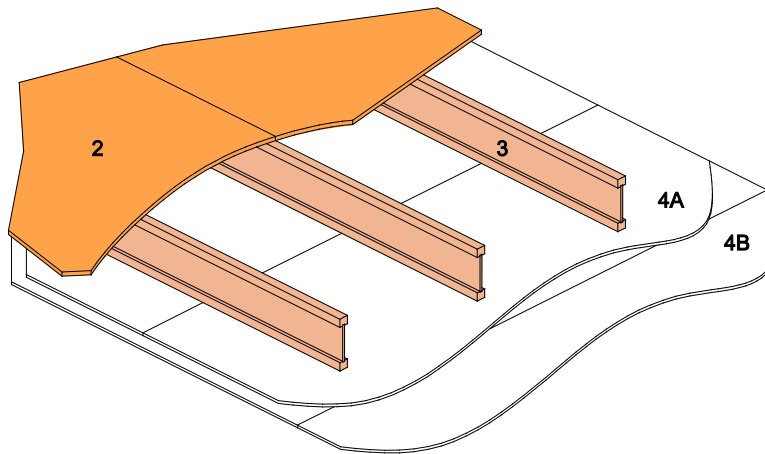

1. **Floor Topping (optional, not shown):** Gypsum concrete, lightweight or normal concrete topping.
2. **Floor Sheathing:** Minimum 23/32-inch-thick tongue-and-groove wood sheathing (Exposure 1). Installed per code requirements with minimum 8d common nails.
3. **Structural Members:** Wood I-joists spaced a maximum of 24 inches on center. See ASTM D 5055 for qualification requirements. Additional requirements are as follows:

Minimum I-joist flange depth: 1-1/2 inches	Minimum I-joist flange area: 2.25 inches ²
Minimum I-joist web thickness: 3/8 inch	Minimum I-joist depth: 9-1/4 inches

Gypsum Wallboard: Two layers of minimum 1/2 inch Type C gypsum wallboard attached with the long dimension perpendicular to the I-joists as follows:

- 4a. **Wallboard Base Layer:** Base layer of wallboard attached to bottom flange of I-joists using 1 inch Type S drywall screws at 12 inches on center. End joints of wallboard centered on bottom flange of the I-joist and staggered.
- 4b. **Wallboard Face Layer:** Face layer of wallboard attached to bottom flange of I-joists through base layer using 1-5/8 inch Type S drywall screws spaced 12 inches on center on intermediate joists and 8 inches on center at end joints. Edge joints of wallboard face layer offset 24 inches from those of base layer. End joints centered on bottom flange of I-joists and offset a minimum of 48 inches from those of base layer. Additionally, wallboard face layer attached to base layer with 1-1/2 inch Type G drywall screws spaced 8 inches on center with a 4" stagger, placed 6 inches from face layer end joints.
5. **Finish System (not shown):** Face layer joints covered with tape and coated with joint compound. Screw heads covered with joint compound.

Fire Test conducted at NGC Testing Services, Inc

Report No. FC-687

January 25, 2007

STC and IIC Sound Ratings								
Joist Spacing	Without Gypsum Concrete				With 3/4" Gypsum Concrete			
	Cushioned Vinyl		Carpet and Pad		Cushioned Vinyl		Carpet and Pad	
	STC	IIC	STC	IIC	STC	IIC	STC	IIC
24"o.c.	-	-	-	-	-	-	49 ^b	55 ^b

^a This assembly may also be used in a fire-rated roof/ceiling application, but only when constructed exactly as described.

^b STC and IIC values established by engineering analysis performed by David L. Adams Associates, Inc.

WIJ-1.6 One-Hour Fire-Resistance-Rated Ceiling Assembly

Floor^a/Ceiling - 100% Design Load - 1 Hour Rating - ASTM E 119 / NFPA 251

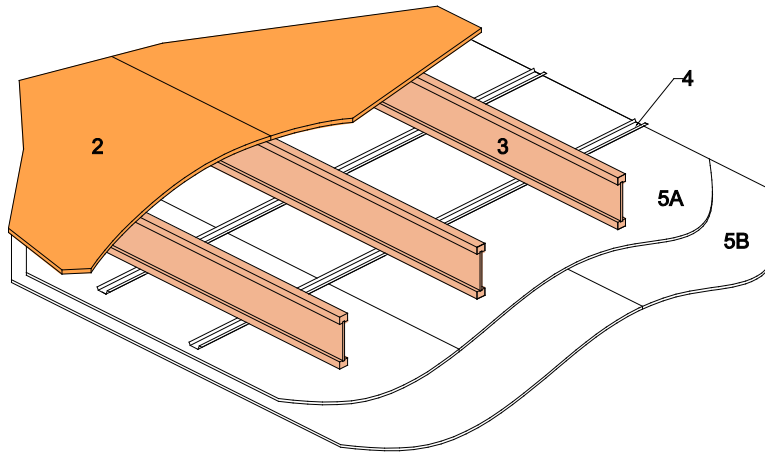

1. **Floor Topping (optional, not shown):** Gypsum concrete, lightweight or normal concrete topping.
2. **Floor Sheathing:** Minimum 23/32-inch-thick tongue-and-groove wood sheathing (Exposure 1). Installed per code requirements with minimum 8d common nails.
3. **Structural Members:** Wood I-joists spaced a maximum of 24 inches on center. See ASTM D 5055 for qualification requirements. Additional requirements are as follows:
 - Minimum I-joist flange depth: 1-5/16 inches
 - Minimum I-joist web thickness: 3/8 inch
 - Minimum I-joist flange area: 1.95 inches²
 - Minimum I-joist depth: 9-1/2 inches
4. **Resilient Channels^b:** Minimum 0.019-inch-thick galvanized steel resilient channel attached perpendicular to the bottom flange of the I-joists with one 1-1/4 inch drywall screw. Channels spaced a maximum of 16 inches on center [24 inches on center when I-joists are spaced a maximum of 16 inches on center].
5. **Gypsum Wallboard:** Two layers of minimum 1/2 inch Type X gypsum wallboard attached with the long dimension perpendicular to the resilient channels as follows:
 - 5a. **Wallboard Base Layer:** Base layer of wallboard attached to resilient channels using 1-1/4 inch Type S drywall screws at 12 inches on center.
 - 5b. **Wallboard Face Layer:** Face layer of wallboard attached to resilient channels through base layer using 1-5/8 inch Type S drywall screws spaced 12 inches on center. Edge joints of wallboard face layer offset 24 inches from those of base layer. Additionally, wallboard face layer attached to base layer with 1-1/2 inch Type G drywall screws spaced 8 inches on center, placed 1-1/2 inches from face layer end joints.
6. **Finish System (not shown):** Face layer joints covered with tape and coated with joint compound. Screw heads covered with joint compound.

Fire Test conducted at National Research Council of Canada Report No. A-4440.1 June 24, 1997

STC and IIC Sound Ratings ^b								
Joist/RC Spacing ^c	Without Gypsum Concrete				With 1" Gypsum Concrete			
	Cushioned Vinyl		Carpet and Pad		Cushioned Vinyl		Carpet and Pad	
	STC	IIC	STC	IIC	STC	IIC	STC	IIC
24"o.c./16"o.c.	46 ^c	44 ^c	46 ^c	61 ^c	58 ^c	47 ^c	58 ^c	67 ^c
16"o.c./24"o.c.	47 ^c	43 ^c	47 ^c	64 ^c	60 ^c	49 ^c	60 ^c	67 ^c

^a This assembly may also be used in a fire-rated roof/ceiling application, but only when constructed exactly as described.
^b Direct attachment of gypsum wallboard in lieu of attachment to resilient channels is typically deemed acceptable. When gypsum wallboard is directly attached to the I-joists, the wallboard should be installed with long dimension perpendicular to the I-joists and sound ratings for WIJ-1.5 should be used.
^c STC and IIC values established by engineering analysis using the AWC Technical Report 15 (TR15) model.
^d STC and IIC values for assemblies with a joist spacing of 16"o.c. may be used for assemblies with joist spacings between 16"o.c. and 24"o.c.

WIJ-1.7 One-Hour Fire-Resistance-Rated Ceiling Assembly

Floor^a/Ceiling - 100% Design Load - 1 Hour Rating - ASTM E 119 / NFPA 251

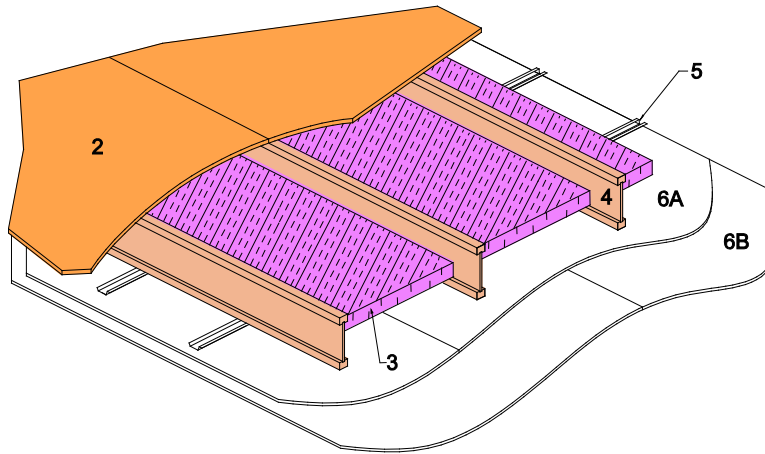

1. **Floor Topping (optional, not shown):** Gypsum concrete, lightweight or normal concrete topping.
2. **Floor Sheathing:** Minimum 23/32-inch-thick tongue-and-groove wood sheathing (Exposure 1). Installed per code requirements with minimum 8d common nails.
3. **Insulation:** Fiberglass insulation placed between I-joists supported by the resilient channels.
4. **Structural Members:** Wood I-joists spaced a maximum of 24 inches on center. See ASTM D 5055 for qualification requirements. Additional requirements are as follows:

Minimum I-joist flange depth: 1-1/2 inches	Minimum I-joist flange area: 2.25 inches ²
Minimum I-joist web thickness: 3/8 inch	Minimum I-joist depth: 9-1/2 inches
5. **Resilient Channels:** Minimum 0.019-inch-thick galvanized steel resilient channel attached perpendicular to the bottom flange of the I-joists with one 1-1/4 inch drywall screw. Channels spaced a maximum of 16 inches on center [24 inches on center when I-joists are spaced a maximum of 16 inches on center].
6. **Gypsum Wallboard:** Two layers of minimum 1/2 inch Type X gypsum wallboard attached with the long dimension perpendicular to the resilient channels as follows:
 - 6a. **Wallboard Base Layer:** Base layer of wallboard attached to resilient channels using 1-1/4 inch Type S drywall screws at 12 inches on center.
 - 6b. **Wallboard Face Layer:** Face layer of wallboard attached to resilient channels through base layer using 1-5/8 inch Type S drywall screws spaced 12 inches on center. Edge joints of wallboard face layer offset 24 inches from those of base layer. Additionally, wallboard face layer attached to base layer with 1-1/2 inch Type G drywall screws spaced 8 inches on center, placed 1-1/2 inches from face layer end joints.
7. **Finish System (not shown):** Face layer joints covered with tape and coated with joint compound. Screw heads covered with joint compound.

Fire Test conducted at National Research Council of Canada Report No. A-4219.13.2 March 23, 1998

STC and IIC Sound Ratings								
Joist/RC Spacing	Without Gypsum Concrete				With 1" Gypsum Concrete			
	Cushioned Vinyl		Carpet and Pad		Cushioned Vinyl		Carpet and Pad	
	STC	IIC	STC	IIC	STC	IIC	STC	IIC
24"o.c./16"o.c.	56 ^b	51 ^b	56 ^b	69 ^b	64 ^b	53 ^b	64 ^b	71 ^b
16"o.c./24"o.c.	55 ^b	48 ^b	55 ^b	67 ^b	64 ^b	54 ^b	64 ^b	67 ^b

^a This assembly may also be used in a fire-rated roof/ceiling application, but only when constructed exactly as described.

^b STC and IIC values established by engineering analysis using the AWC Technical Report 15 (TR15) model, assuming minimum 3.5"-thick fiberglass insulation is used.

^c STC and IIC values for assemblies with a joist spacing of 16"o.c. may be used for assemblies with joist spacings between 16"o.c. and 24"o.c.

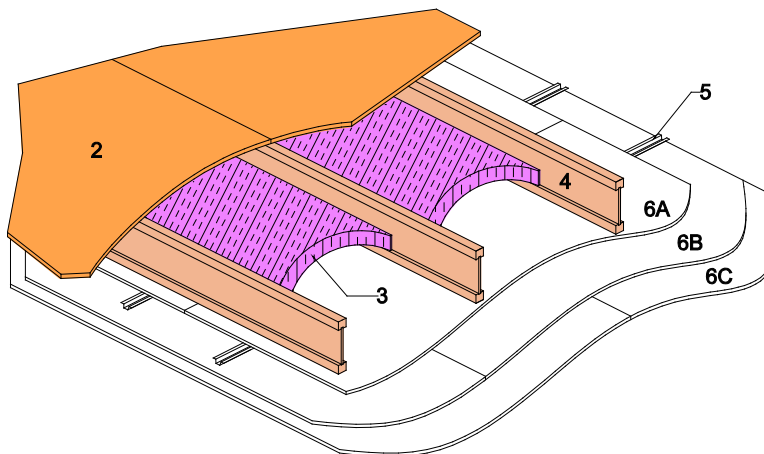
WIJ-2.1 Two-Hour Fire-Resistance-Rated Ceiling Assembly**Floor^a/Ceiling - 100% Design Load - 2 Hour Rating - ASTM E 119 / NFPA 251**

1. **Floor Topping (optional, not shown):** Gypsum concrete, lightweight or normal concrete topping.
 2. **Floor Sheathing:** Minimum 23/32-inch-thick tongue-and-groove wood sheathing (Exposure 1). Installed per code requirements.
 3. **Insulation:** Minimum 3-1/2-inch-thick unfaced fiberglass insulation fitted between I-joists supported by stay wires spaced 12 inches on center.
 4. **Structural Members:** Wood I-joists spaced a maximum of 24 inches on center. See ASTM D 5055 for qualification requirements. Additional requirements are as follows:

Minimum I-joist flange depth: 1-1/2 inches	Minimum I-joist flange area: 2.25 inches ²
Minimum I-joist web thickness: 3/8 inch	Minimum I-joist depth: 9-1/4 inches
 5. **Furring Channels:** Minimum 0.0179-inch-thick galvanized steel hat-shaped furring channels, attached perpendicular to I-joists using 1⁵/₈-inch-long drywall screws. Furring channels spaced 16 inches on center (furring channels used to support the second and third layers of gypsum wallboard). Based on ASTM E2032, minimum 0.019-inch-thick galvanized steel resilient channels may be used in lieu of hat-shaped furring channels if installed at the same spacing and attached in the same manner. In order to achieve the sound ratings given below, resilient channels must be used in lieu of hat-shaped furring channels.
 6. **Gypsum Wallboard:** Three layers of minimum 5/8 inch Type C gypsum wallboard as follows:
 - 6a. **Wallboard Base Layer:** Base layer of wallboard attached to bottom flange of I-joists using 1-5/8 inch Type S drywall screws at 12 inches on center with the long dimension of wallboard perpendicular to I-joist. End joints of wallboard centered on bottom flange of the I-joist and staggered from end joints in adjacent sheets.
 - 6b. **Wallboard Middle Layer:** Middle layer of wallboard attached to furring channels using 1 inch Type S drywall screws spaced 12 inches on center with the long dimension of wallboard perpendicular to furring channels. End joints staggered from end joints in adjacent sheets.
 - 6c. **Wallboard Face Layer:** Face layer of wallboard attached to furring channels through middle layer using 1-5/8 inch Type S drywall screws spaced 8 inches on center. Edge joints of face layer of wallboard offset 24 inches from those of middle layer. End joints of face layer of wallboard staggered with respect to the middle layer.
- Finish System (not shown):** Face layer joints covered with tape and coated with joint compound. Screw heads covered with joint compound.

Fire Test conducted at Gold Bond Building Products Research Center December 16, 1992

Third Party Witness: PFS Corporation Report No: #92-56

WIJ-2.1 continues on following page.

WIJ-2.1 continued.

STC and IIC Sound Ratings (with Resilient Channels)								
Joist/RC Spacing	Without Gypsum Concrete				With 1" Gypsum Concrete			
	Cushioned Vinyl		Carpet and Pad		Cushioned Vinyl		Carpet and Pad	
	STC	IIC	STC	IIC	STC	IIC	STC	IIC
24"o.c./16"o.c.	-	-	49 ^b	54 ^b	58	45	58	64

^a This assembly may also be used in a fire-rated roof/ceiling application, but only when constructed exactly as described.

^b STC and IIC values established by engineering analysis performed by David L. Adams Associates, Inc.

C1 General Requirements for Fire Design

C1.1 General

C1.1.1 Scope

The provisions of this standard provide prescriptive and calculation procedures for fire design of wood products, assemblies and connections included within the scope of the ANSI/AWC *National Design Specification (NDS) for Wood Construction* [1]. This standard can be used to demonstrate compliance with fire design provisions of the applicable building code.

C1.1.2 Design Methods

Design methods in this standard are based on the provisions of this Standard and the fire exposure and acceptance criteria specified in reference standards.

C1.1.3 Type of Construction

Building codes typically limit building heights and areas based on expected fire performance. To facilitate this objective, building codes used in the United States typically define “Types of Construction” which determine the fire-resistance ratings, materials, and detailing requirements for the building. Other considerations, such as occupancy, location, or the use of automatic sprinkler systems may further modify permissible building heights and areas.

C1.2 Terminology

- DOUBLE-STUD WALL.** A double-stud wall is fabricated with two rows of studs with common top and bottom plates that are typically more than twice the width of the studs. Studs on opposite edges of the plates are typically aligned and separated by a gap to reduce sound or thermal transmission paths through the assembly. The width of end studs may match the full width of the plates. An example would be 2x8 plates (7-1/4” wide) with two rows of 2x4 (3-1/2” wide) aligned studs. The wall cavity can be filled or partially filled with insulation for improved thermal or acoustic performance.
- DOUBLE WALL.** A double wall is a single wall fabricated with two walls that are set next to each other, sometimes with insulation between them, to provide additional sound, thermal, and/or fire resistance. A double wall may be constructed either with or without membranes attached to the edges of the studs between the walls, depending on structural, fire, and acoustic design requirements. The wall cavities can be filled or partially filled with insulation for improved thermal or acoustic performance.

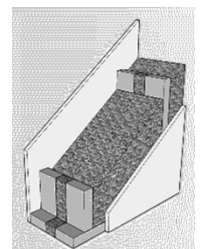
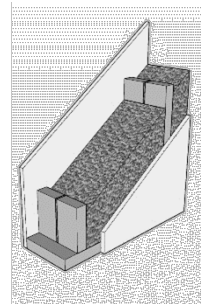

- **STAGGERED-STUD WALL.** A staggered-stud wall is a single wall fabricated with two rows of studs with common top and bottom plates that are typically less than twice the width of the studs. Adjacent studs (along the length of the wall) are placed at opposite edges of top and bottom plates without contacting each other to reduce sound and thermal transmission paths through the assembly. The width of end studs typically matches the full width of the plates. An example would be 2x6 plates (5-1/2" wide) with two rows of 2x4 (3-1/2" wide) staggered studs. The wall cavity can be filled or partially filled with insulation for improved thermal or acoustic performance.

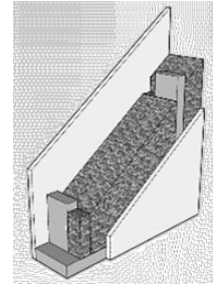

- **FIRE SEPARATION DISTANCE (FSD).** Building codes use the concept of fire separation distance to determine construction requirements for exterior walls and projections based on proximity to other buildings which exist on the same site or adjacent sites or may exist in the future. The intent is to prevent a fire in one building from spreading to adjacent buildings. The FSD for specific Types of Construction and Occupancy Groups often determines the required fire-resistance-ratings for exterior walls, maximum area of openings and requirements for opening protection in exterior walls, and maximum distances of projections from exterior walls. In addition, the egress pathways on the exterior of a building require minimum FSD to ensure safe egress in the event of fire.

Where there is only one building on a lot, the FSD is determined based on the distance from the exterior wall to the nearest lot line or to the centerline of the adjacent street, alley, or right-of-way. Where multiple buildings occur on the same lot, the FSD between buildings is determined by establishing an imaginary lot line between buildings, such that the building code requirements for exterior walls and projections are met for both buildings. The imaginary line does not have to be placed halfway between the two buildings, but once it is established, both buildings must meet the requirements associated with their respective FSD. In some cases, exterior walls and projections on an existing building may require modification to meet code requirements when a second building is added in close proximity. Establishing the imaginary line as close to the original building as permitted by the existing construction will permit the maximum flexibility in design and construction of the exterior walls and projections of the new building without requiring modification of the existing building.

C1.3 Notation

The system of notation used in the Specification helps to identify the meaning of certain frequently used symbols. Adjustment factors, identified by the symbol “C”, modify reference design values for conditions of use, geometry, or stability. The subscripts “D”, “F”, “L”, etc., are used to distinguish between different adjustment factors. In certain cases, upper- and lower-case subscripts of the same letter (“D” and “d”) are used to denote two different adjustments (load duration factor and penetration depth factor for split ring and shear plate connections, respectively). There is no particular significance to the use of the same letter with different cases for different adjustment factors. The symbols “F” and “F” denote reference and adjusted design values, respectively; where adjusted design values represent reference design values multiplied by all applicable adjustment factors. The symbol “f” indicates the actual or induced stress caused

by the applied loads. The subscripts “b”, “t”, “c”, “v”, and “c_⊥” indicate bending, tension parallel to grain, compression parallel to grain, shear, and compression perpendicular to grain stress, respectively.

C1.4 Material Standards

Alternative materials and methods may be used where the authority having jurisdiction determines that the proposed design provides equivalent performance and complies with the intent of the applicable building code.

C1.4.1 Wood Products

References to product standards for wood products, including sawn lumber, glued lumber, structural glued laminated timber, prefabricated wood I-joists, structural composite lumber, prefabricated wood trusses, panel and siding products, and cross-laminated timber are provided. For proprietary or specialty products, further information may be available from the manufacturer. Wood products are often glued together to make larger cross sections. Where used to make larger cross sections, secondary bondline adhesives are required to meet minimum heat resistance and durability requirements of the primary adhesive used to manufacture the product or as required in ANSI 405.

C1.4.2 Gypsum Panel Products

References to product standards for gypsum panel products used in provisions of the FDS, including gypsum board and glass mat gypsum panel products, are provided. For additional information on gypsum products and the defined uses of those products, see GA-223 [33].

C1.4.3 Insulation

References to product standards for mineral fiber insulation, including fiberglass or mineral wool, are provided.

C1.4.4 Fasteners

References to product standards for bolts, lag screws, wood screws, screws used to attach gypsum panel products, and nails are provided.

C1.4.5 Metal Parts

For design of metal parts, such as metal plates and hangers, the user is directed to use code-recognized design procedures.

C1.4.6 Concrete or Masonry Parts

For design of concrete or masonry parts, such as foundations and walls, the user is directed to use code-recognized design procedures.

C1.5 Heavy Timber

Heavy timber is a classification of wood members or assemblies of minimum dimensions, specific to particular applications such as heavy timber framing members, roof decks, floor decks and walls.

C1.5.1 Heavy Timber Requirements

Minimum sizes for sawn lumber, structural glued laminated timber, glued lumber, structural composite lumber, cross-laminated timber, mechanically-laminated timber and wood structural panels have been provided, based on the application. It is important to note that while small lumber members (e.g., 1x3 lumber) and panels (e.g., ½” thick) are not considered “heavy timber elements” when used on their own, they can be part of a heavy timber roof, floor, or wall assembly when used as prescribed.

Heavy timber provisions have historically provided minimum thicknesses of wood products that are required over heavy timber floor decks. Noncombustible toppings consistent with toppings specified in the International Building Code [2] for Types IV-A and IV-B construction, are included in FDS Table 1.5.3 to allow for their use in other construction types.

C1.6 Material Combustibility

A combustible material is any material that does not qualify as a noncombustible material.

C1.6.1 Noncombustible Materials

To qualify as a noncombustible material, the material must be tested in accordance with ASTM E136 or ASTM E2652 and meet the ASTM E136 requirements. A composite material such as gypsum wallboard, which has a base layer of noncombustible material and a thin combustible surface layer that has a thickness of not more than 1/8-inch and that meets specific flame spread limits, is generally acceptable as a noncombustible material.

C1.6.2 Combustible Materials

C1.6.2.1 Combustible materials used as finish materials may be required to meet specific requirements in FDS Chapter 2 with regard to ignition resistance, flame spread, and flame propagation. In addition, construction using combustible materials typically requires the use of firestopping, fireblocking, and draftstopping to prevent or restrict the passage of flames or hot gases into fire-resistance rated assemblies or through concealed spaces as discussed in Chapter 2.

C1.7 Fire-Resistance-Rated Wood Members and Assemblies

The requirements in FDS 1.7 are intended to provide a minimum level of performance for wood members and assemblies required to have a fire-resistance rating.

C1.7.1 Fire-Resistance-Rated Construction

Fire-resistance ratings for wood members and assemblies are to be determined, by testing or calculation, in accordance with FDS Chapter 3.

C1.7.2 Continuity of Fire-Resistance Rating

The need for continuity of a fire-resistance rating is established by the building code based on the function and location in the building. Openings in the span of an assembly (between intersections with other walls, floors, or roofs), or penetrations into or through it for mechanicals, plumbing, or electrical installations, may or may not be required to be protected. For openings in horizontal assemblies such as floors, the codes almost always require protection to maintain continuity of fire resistance. But that is not the case with fire-resistance-rated walls. It is only the openings and penetrations in walls with specific fire safety functions (commonly designated fire walls, fire barriers, or other names for walls serving a protective separation function) that are limited or required to be protected to provide continuity of fire resistance. Walls that are required to be fire-resistance-rated only as a function of construction type can have unlimited openings and unprotected penetrations.

The required fire-resistance rating of an assembly is assumed to be provided from intersection to intersection of other connected walls, floors, and roofs. The codes contain no criteria for continuity of assembly fire resistance through intersections with other building assemblies or structural members. Specific protections at these locations may be required due to other code requirements, such as requirements for fireblocking within concealed spaces, requirements for equal fire resistance of supporting construction to that of supported assemblies, or requirements for the protection of designed joints between assemblies with fire-resistant joint systems. Otherwise, continuity of fire resistance at the intersections of rated assemblies with each other or with other structural members should not be assumed and is generally unregulated, since it would be difficult to quantify the real safety benefit of such regulation. (For the protection of connectors and connections critical to the performance of rated beams, columns, and other structural members, see FDS 1.7.7).

Where continuity of the fire-resistance rating is required, the fire resistance must be maintained for the full extent of the assembly or assemblies involved. It is not required to provide continuity of materials, but only to ensure that the required fire resistance rating is maintained. For example, when a fire-resistance-rated wall assembly is required to have continuity for a fire safety separation function such as the protection of an exit shaft, it may be necessary to demonstrate that intersecting walls or floors do not adversely affect the fire-resistance of the exit shaft wall. As another example, a portion of a wood member may be protected by gypsum board, while another portion of the member is protected by wood or other materials, provided that the required fire-resistance rating is maintained.

C1.7.3 Supporting Construction

Where construction supports gravity loads from a fire-resistance-rated building element or assembly, the construction is normally required to be capable of supporting the loads for the full time associated with the required fire-resistance rating of the supported element or assembly. Gravity loads are specifically cited because it is assumed that a fire event could occur simultaneously with design live and dead loads applied to the structure. It is not typically required to design for fire events simultaneous with lateral loads.

C1.7.3.1 Platform construction. In platform construction where a floor-ceiling assembly supports gravity loads from a fire-resistance rated wall, portions of the floor-ceiling construction that support the wall normally have a fire-resistance rating that is equal or greater than the required fire-resistance rating of the wall in order to meet the requirements of FDS 1.7.3. However, portions of the floor-ceiling construction that do not support the fire-resistance rated wall only need to meet the fire-resistance ratings for the floor-ceiling assembly. A common example of this requirement is a 2-hr exterior wall supported by a floor assembly. In this example, the supporting rim board, blocking, and/or the ends of floor joists must be capable of supporting the exterior wall for the required 2-hr fire-resistance rating of the exterior wall, but the remaining portion of the floor joists may have a lesser fire-resistance rating as required by the Type of Construction. Note that, where a floor-ceiling assembly supports an exterior wall that is required to be of noncombustible materials or fire-retardant-treated wood, the material requirements of the floor-ceiling assembly are in accordance with requirements for interior building elements for the Type of Construction, including portions of the floor-ceiling construction that support gravity loads from the exterior wall.

C1.7.4 Column Protection

Wood columns required to have a fire-resistance rating are to be designed in accordance with FDS Chapter 3. FDS 1.7.4.1 and 1.7.4.2 clarify how protection from ceiling and wall membranes is to be considered when designing a fire-resistance-rated column. FDS 1.7.4.3 recognizes that larger wood members within a wall assembly have greater fire resistance than smaller members, so that vertical wood members with dimensions greater than the wood studs can conservatively be assigned the same fire-resistance rating as the stud wall assembly without requiring additional protection or analysis.

C1.7.5 Beam Protection

Wood beams required to have a fire-resistance rating are to be designed in accordance with Chapter 3.

FDS 1.7.5.1 recognizes that failure of one span of a fire-resistance rated beam may affect the load-carrying capacity and fire-resistance rating of the remaining span(s), therefore, all spans of multi-span beams are required to be designed for the maximum required fire-resistance rating of any of the spans, unless the failure of a single span can be shown to not reduce the fire-resistance rating of the remaining span(s).

FDS 1.7.5.2 through 1.7.5.3 clarify how protection from ceiling membranes is to be considered when designing fire-resistance-rated beams, accounting for different consequences of failure and different levels of required protection based on the number of floors or roofs supported. FDS 1.7.5.4 recognizes that larger wood members within a horizontal assembly have greater fire resistance than smaller members, so that wood members with dimensions greater than the wood joists can be assigned the same fire-resistance rating for the wood joist assembly without requiring additional protection or analysis.

C1.7.6 Truss Protection

The fire-resistance rating of wood trusses and wood truss assemblies are typically established based on tests. Calculations using the provisions of FDS Chapter 3 for the design of wood members should be considered, but design of truss connections at chord splices and web-to-chord

connections is beyond the provisions of this Standard. Approval should be based on tests or analyses which demonstrate that the fire-resistance of the truss or assembly meets the required fire resistance.

FDS 1.7.6.1 recognizes that failure of any component of a truss can result in failure of the entire truss, requiring all of the truss to be designed for its required fire-resistance rating. FDS 1.7.6.2 and 1.7.6.3 clarify how protection from ceiling membranes is to be considered when designing fire-resistance-rated trusses, accounting for different consequences of failure and different levels of required protection based on the number of floors or roofs supported.

C1.7.7 Protection of Connections

Where a wood member or a wood assembly is required to have a fire-resistance rating, wood structural connections in that member or assembly must perform their function for the time corresponding to the required fire resistance rating. Since neither ASTM E119 nor UL 263 contain provisions for testing the fire resistance of structural connections, these connections are designed using the requirements of FDS 3.10. For wood structural connections, all required components of the connection are required to be protected, including any metal connectors, fasteners that are part of the structural connection, and portions of the connected members that are part of the structural connection. For further information on protection of connections, see C3.10.

For light-frame wood assemblies, such as wall, floor, and roof assemblies, testing and calculations have demonstrated that structural connections within a tested fire-resistance rated assembly are adequately protected to ensure that the assembly meets the required fire resistance rating. Intersections of repetitive-member fire-resistance rated wall and floor assemblies in light-frame wood construction are not considered connections needing protection; however, designed joints between the assemblies may require protection by fire-resistant joint systems. See Section C1.7.8 for more information about intersections.

C1.7.8 Joints and Intersections Between Fire-Resistance-Rated Assemblies

Where required by the applicable building code, intersections of fire-resistance-rated assemblies are required to be detailed to prevent burn-through from occurring before the required thermal separation time is reached (see FDS 3.6). Reference is made to FDS 2.5.1.3 for fire-resistant joint system (FRJS) requirements, which must be used in locations where the building code requires the use of a FRJS at joints between fire-resistance-rated assemblies.

C1.7.8.1 Edges of membranes. Detailing at edges of membranes must be designed to avoid premature entry of fire into the protected assembly at such locations. Specific details that are deemed to meet this requirement at ceiling-to-wall intersections and wall-to-wall intersections are provided in FDS 1.7.8.1.1 and in 1.7.8.1.2, respectively. Where edges of membrane protection intersect exposed wood members, special detailing may be required to prevent fire from circumventing the gypsum protection due to charring of the CLT at the gypsum panel edge (see Figure C1-1).

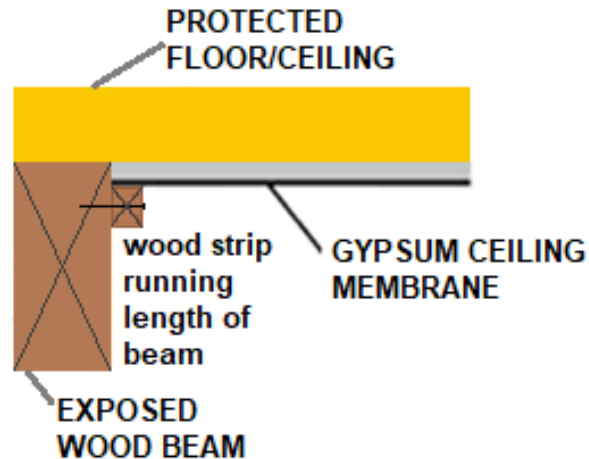

FIGURE C1-1 EXAMPLE OF A GYPSUM CEILING MEMBRANE ABUTTING AN EXPOSED WOOD BEAM.

C1.7.8.1.1 Where a gypsum panel ceiling membrane intersects a gypsum panel wall membrane, attachment of the ceiling membrane prior to attachment of the wall membrane allows edges of the ceiling membrane to extend over, and be supported by, the top edge of the wall membrane as shown in Figure C1-2. Typically, ceiling gypsum panels are not attached to the ceiling framing close to the wall framing to avoid damage of the ceiling gypsum panel close to edges and ends of the panel. By attaching the ceiling membrane first, the wall membrane can be installed tight to the underside of the ceiling membrane. This provides support and prevents excessive sagging at the edge of the ceiling gypsum panels, while also minimizing the formation of gaps due to gypsum contraction during fire exposure.

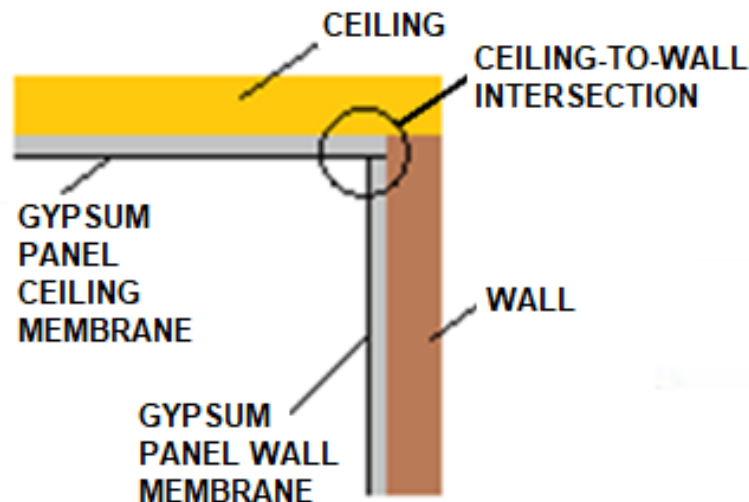

FIGURE C1-2 GYPSUM PANEL CEILING AND WALL MEMBRANE INSTALLATION AT CEILING-TO-WALL INTERSECTION

C1.7.8.1.2 Where a gypsum panel wall membrane intersects at a wall-to-wall intersection, attachment of the gypsum panel membrane on the wall with a greater fire resistance rating prior to attachment of the gypsum panel membrane on the intersecting wall with a lesser fire-resistance rating minimizes the formation of gaps at the intersections due to gypsum contraction during the fire exposure (as shown in Figure C1-3).

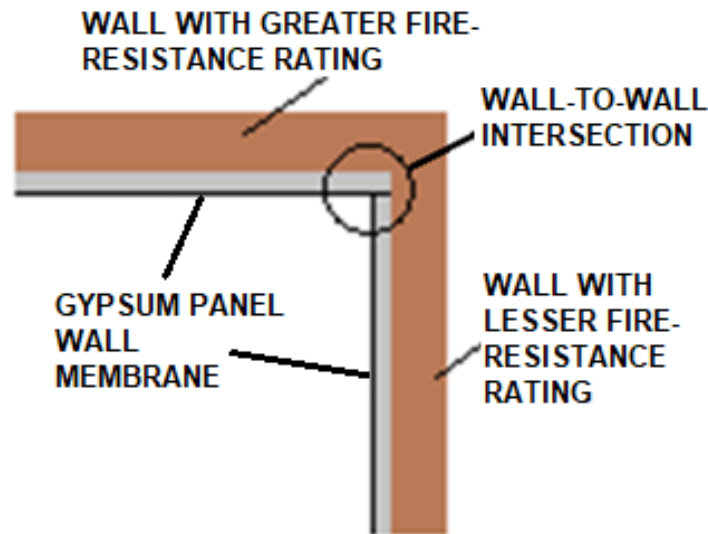

FIGURE C1-3 GYPSUM PANEL WALL MEMBRANE INSTALLATION AT WALL-TO-WALL INTERSECTION

C1.7.8.2 *Wood members entering concrete or masonry fire walls.* The 4-inch distance required between “beam pockets” on opposing sides of masonry or concrete fire walls has historically been shown to adequately protect the ends of wood structural members and prevent the spread of fire through the fire wall. Where the fire wall is hollow or where there are hollow units within the wall at the location of a “beam pocket,” the requirement for installing 4 inches of non-combustible materials within the hollow portion of the fire wall around all sides of the wood structural member end is intended to provide this same level of protection.

C1.7.9 Limitations and Protection of Openings

Limitations and requirements for protection of openings and penetrations in fire-resistance-rated assemblies vary. The user is directed to check with the requirements of the applicable building code. See also C1.7.2.



C2 Ignition and Flammability

C2.1 General

C2.1.1 Scope

The provisions of Chapter 2 provide ignition and flammability requirements that have been coordinated with requirements of model building codes but have been expanded to address specific requirements for wood materials and assemblies.

C2.2 Ignition Resistance

Where ignition resistance of combustible exterior wall coverings is regulated, materials are required to be tested in accordance with NFPA 268 [3] and not exhibit sustained flaming when exposed to an incident radiant heat flux of 12.5 kW/m². Since most wood and wood-based products do not exhibit sustained flaming when exposed to a radiant heat flux of 12.5 kW/m² or less, testing in accordance with NFPA 268 is not required for wood or wood-based products used as exterior wall coverings. Accordingly, most building codes do not require NFPA 268 testing of exterior wall coverings that are wood and wood-based products.

C2.3 Flame Spread Performance of Wood Products

C2.3.1 Interior Wall and Ceiling Finish Materials

C2.3.1.1 Interior wall and ceiling finishes are typically tested using ASTM E84 [4] or UL 723 [5] for flame spread and smoke development and are classified in accordance with their reported flame spread index (FSI) and smoke developed index (SDI) as indicated in FDS Table 2.3.1. Model building codes provide flame spread classification requirements for wall and ceiling finishes based on occupancy, location within the building, and presence or absence of automatic sprinklers. For example, exit stairways and corridors typically have more restrictive requirements than other rooms within the building, and unsprinklered construction typically has more restrictive requirements than sprinklered construction. NFPA 286 is permitted to be used in lieu of ASTM E84 or UL 723 to meet the requirements of Class A; however, ASTM E84 or UL 723 are the primary methods used for wood products. Most occupancies in sprinklered buildings are required to meet the requirements of Class C interior finish in rooms, and Class B or C for corridors and exit elements. In unsprinklered buildings, most occupancies are required to meet the requirements of Class B or C for rooms and Class A or B for corridors and exit elements.

C2.3.1.2 Materials tested in accordance with ASTM E84 or UL 723 are provided in FDS Supplement A as a reference to designers. These test assemblies can be used directly since they were tested in accordance with the code-referenced test standards. All wood products listed in FDS Supplement A have SDI ratings below 450.

C2.3.2 Interior Floor Finish Materials

With the exception of traditional floor finishes, including wood, vinyl, linoleum or terrazzo, and resilient floor covering materials that are not comprised of fibers, the IBC requires interior floor finish and floor covering materials to be tested in accordance with ASTM E648 or NFPA 253 and classified based on minimum critical radiant heat flux. Interior floor finish materials in enclosures for stairways and ramps, exit passageways, corridors and rooms or spaces not separated from corridors by partitions extending from the floor to the underside of the ceiling are limited to Class I in Occupancy Groups I-1, I-2 and I-3 and not less than Class II in Occupancy Groups A, B, E, H, I-4, M, R-1, R-2 and S. However, where a building is equipped throughout with an automatic sprinkler system in accordance with NFPA 13 [9] or NFPA 13R [10], Class II materials are permitted in any area where Class I materials would otherwise be required, and materials complying with ASTM D2859 [11] are permitted in any area where Class II materials would otherwise be required.

C2.3.3 Fire-Retardant-Treated Wood

For approval of fire-retardant-treated wood (FRTW), the U.S. model building codes reference the use of ASTM E84 or UL 723 with additional requirements for compliance with the following limits:

- flame spread index of 25 or less,
- no evidence of significant progressive combustion when the test is continued for an additional 20-minute period, and
- flame front does not progress more than 10.5 feet beyond the centerline of the burners at any time during the test.

In the FDS, ASTM E2768 [12] is referenced since that standard incorporates ASTM E84 and includes the additional building code requirements listed above. In addition, ASTM E84-19 states, “Materials required by the user to meet an extended 30-min duration tunnel test shall be tested in accordance with Test Method E2768.” Whether impregnated with chemicals by a pressure process or by other means during the manufacturing process, all fire-retardant-treated wood products must meet the same performance requirements of ASTM E2768. More recent editions of the U.S. model building codes also reference ASTM E2768 as an alternative to using E84 with the additional building code requirements mentioned previously. ASTM D2898 is also referenced where FRTW is to be used in damp or wet conditions or will be exposed to weather. Fire-retardant-treated wood that is intended to be used in damp, wet or weather-exposed locations must be tested in accordance with, and comply with the conditions of classification provided in, ASTM E2768 after being subjected to accelerated weathering in accordance with ASTM D2898 and must be labeled as “exterior.” Fire-retardant-treated wood that is not labeled “exterior” is required to maintain a moisture content of 28% or less when subjected to conditions of 92% relative humidity in accordance with ASTM D3201. This moisture content limit, which applies to FRTW used in interior applications, is intended to ensure that hygroscopicity is not excessively high.

C2.3.3.1 Design values: The standards referenced in FDS 2.3.3.1 specify testing and analysis requirements for determining treatment adjustment factors for FRTW based on expected end-use conditions in several climate zones. However, these standards separate both the immediate and long-term effects of the chemical treatment from the effects of moisture and temperature on

untreated wood. For this reason, it is important that the appropriate treatment adjustment factor be applied cumulatively with the NDS adjustment factors for moisture and temperature, as well as any other adjustment factors applicable to the end use application.

Design values for fire-retardant-treated softwood plywood and fire-retardant-treated sawn lumber are determined starting with published design values for untreated plywood or lumber then multiplying by the appropriate treatment adjustment factor and all other adjustment factors applicable to untreated wood. However, laminated veneer lumber (LVL) is treated differently; ASTM D8223 requires reference design values to be established specifically for fire-retardant-treated LVL along with adjustment factors to account for long term effects of the treatment under expected climatological conditions.

C2.3.4 Wood-Based Products with Fire-Retardant Coatings

The word “approved”, as defined in FDS 1.2, in the first sentence of this section, is intended to clarify that all wood-based products with fire-retardant coatings are required to be approved by the authority having jurisdiction. For interior wall and ceiling applications, wood-based products with fire-retardant coatings must be classified in accordance with FDS 2.3.1, based on testing in accordance with ASTM E84 or UL 723. If intended for use in place of FRTW, wood-based products with fire-retardant coatings must meet the same performance requirements of ASTM E2768. Where fire-retardant coatings are used on wood-based products intended for structural applications, wood strength and stiffness reductions associated with application of and long-term exposure to the fire-retardant coating should be considered in the approval process and accounted for in design.

C2.4 Vertical and Lateral Flame Propagation

C2.4.1 Exterior Wall Coverings

Building codes typically regulate the coverage area and the coverage height for combustible wall coverings based on the type of construction and proximity to adjacent buildings. Based on FDS 2.4.1.1 and 2.4.1.2, where FRTW suitable for exterior use is used as exterior wall covering, the coverage area is unlimited regardless of the proximity to other buildings and the permissible coverage height is increased from 40 feet to 60 feet when the exterior wall with the FRTW exterior wall covering is tested in accordance with and meets the acceptance criteria of NFPA 285.

FDS 2.4.1.3 requires concealed space behind wood exterior wall coverings or architectural elements to be limited in thickness and fireblocked to prevent flame propagation within the concealed space.

FDS 2.4.1.4 prohibits wood wall coverings from extending above the top of exterior walls.

FDS 2.4.1.5 addresses wood veneers. It should be noted that wood “veneers” in this context refers to nonstructural facings attached to walls for ornamentation, insulation, or protection. This usage does not refer to the wood veneers used to manufacture plywood or structural composite lumber.

C2.4.2 Building Projections

Balconies and similar projections of wood or wood-based materials extending to less than five feet from a property line, or a line used to establish fire separation distance are subject to similar limitations as combustible exterior wall coverings; therefore, requirements should be sought in the applicable building code.

C2.5 Firestopping, Fireblocking and Draftstopping

C2.5.1 Firestopping

Firestopping is used to prevent the passage of fire through fire-resistance-rated construction. Through-penetration firestop systems are used to prevent the passage of fire and hot gases through fire-resistance-rated construction caused by penetrations, such as pipe or ducts. Membrane-penetration firestop systems are used to prevent the passage of flames and hot gases into fire-resistance-rated assemblies through penetrations in protective membranes. Fire-resistant joint systems are used to prevent the passage of fire and hot gases through design joints between fire-resistance-rated assemblies. Model building codes typically require all three firestopping systems to be tested and approved. The provisions of FDS 2.5.1 clarify that the wood members and wood assemblies can be designed in accordance with FDS Chapter 3 and only the firestop systems need to be tested and approved.

C2.5.2 Fireblocking

In wood construction, fireblocking is used to restrict the passage of flames within and between concealed spaces constructed using combustible materials that are exposed within the concealed space. Fireblocking is not typically required in concealed spaces where no combustible materials are exposed.

C2.5.2.1 Fireblocking materials: Materials listed in FDS 2.5.2.1, Items 1 through 9 have historically been permitted for use as fireblocking. FDS 2.5.2.1 Item 10 was added to allow the designer flexibility to determine whether other materials can be used as fireblocking by limiting the passage of flames for at least 15 minutes when exposed to the standard fire in ASTM E119. Table C2.5.2.1 provides calculated burn-through times for existing fireblocking materials using the thermal separation time or the burn-through time at abutting edges for each material based on the provisions of FDS 3.5.1 for wood, FDS 3.5.2 for Type X gypsum panel products, or FDS 3.5.3 for insulation used as fireblocking materials.

Table C2.5.2.1: Calculated Burn-Through Times of Fireblocking Materials

Material	Abutting Ends and Edges Backed	Calculated Burn-through Time (minutes)
One layer of 2-inch (nominal) lumber (1½-inch thick)	No	26
One layer of 1½-inch thick (minimum) structural composite lumber	No	18
One layer of 1½-inch thick (minimum) engineered wood rim board	No	18
Two layers of 1-inch (nominal) lumber (¾-inch thick)	abutting ends and edges in each layer spaced at least 2 inches apart.	26
One layer of 23/32-inch wood structural panel sheathing	all panel edges backed by 23/32-inch wood structural panels, wood framing, or wood blocking.	20
One layer of 3/4-inch particleboard	all panel edges backed by 3/4-inch particleboard, wood framing, or wood blocking.	21
One layer of 1/2-inch regular gypsum board	all panel edges backed by wood framing or wood blocking.	15 ¹
Batts or blankets of minimum 2.5 pcf mineral wool filling the entire cross section of the wall cavity, installed to be securely retained in place, and tightly packed around piping, conduit, or similar obstructions.		19

¹ Assumed value, verified by testing.

C2.5.3 Draftstopping

In wood construction, draftstopping is used to subdivide large areas and restrict the movement of air and hot gases between combustible concealed spaces within floor-ceiling assemblies, and within attic spaces.

C2.5.3.1 Draftstopping materials: Materials listed in FDS 2.5.3.1 have historically been permitted for use as draftstopping.



C3 Fire Resistance

C3.1 General

C3.1.1 Scope

Chapter 3 provides a means of determining the fire resistance of wood construction that is covered under the scope of the National Design Specification® (NDS®) for Wood Construction [1]. The scope of Chapter 3 is aligned with that of Chapter 16 of the NDS.

C3.1.2 Fire Exposure

The provisions of Chapter 3 are based on the standard fire exposure and acceptance criteria specified in ASTM E119 [13] or UL 263 [14] and do not, therefore, apply to design fires used in performance-based design. Performance-based design using a design fire scenario other than the standard fire exposure prescribed in E119 or UL 263 requires use of char rate data corresponding to the specific fire exposure under consideration. This is beyond the current scope of the FDS.

C3.1.3 Fire-Resistance Rating

Typically, individual wood structural members that are required to have a fire resistance rating need only meet the structural requirements for the fire resistance time in ASTM E119 or UL 263. Wood assemblies that are required to have a fire-resistance rating need to meet the structural resistance requirements, provide adequate thermal separation (limit the average temperature rise on the unexposed side to 250°F, and limit the maximum temperature rise on the unexposed side to 325°F), and prevent burn-through for the fire resistance time. For some wood structural members, such as cross-laminated timber, the member itself can be designed to meet the requirements for structural resistance, thermal separation, and burn-through.

C3.1.3.1 Design requirements: This Specification defines a national standard of practice for the fire design of wood members, wood assemblies, and wood connections. It references the NDS as the base document for structural design and builds on those structural requirements to meet the fire-resistance rating requirements in the building code.

C3.1.3.2 Reference design values: Reference design values and specific structural design provisions to be used with the provisions of the Specification are contained in the NDS or documents referenced therein. Applicable adjustment factors to NDS reference design values are provided in FDS 3.3.2.

C3.1.3.3 Test loads: Where the fire-resistance rating is determined by testing, ASTM E119 requires that the total load (w_T) to be applied throughout a fire-resistance rating test must induce the maximum allowable stress in the member or assembly being tested unless the intent of the test is to apply and report a reduced load.

Allowable Stress Design (ASD): For ASD, the superimposed load (w_S) for a wood member, wood assembly, or a wood connection to be applied throughout a fire-resistance rating test is calculated as w_T minus the member or assembly dead load (w_D). For a wood member, wood assembly, or a wood connection, the superimposed load (w_S) is calculated as shown in FDS Equation 3.1-1. Guidance on calculating the full ASD load is provided for wood-frame walls in ASTM D6513 [15] and for wood-frame floor-ceiling assemblies in ASTM D7746 [16].

Strength Design (LRFD): For LRFD, the superimposed load (w_{S-LRFD}) to be applied throughout a fire-resistance rating test is calculated in accordance with ASTM E119 Appendix X7. Recognizing that LRFD design values for wood construction were calibrated for a live/dead ratio of 3 and a time effect factor (λ) of 0.7, the provisions of ASTM E119 Appendix X7 can be simplified for wood design as follows:

From ASTM E119 Appendix X7:

$$w_{T-LRFD} = \frac{1}{\alpha} \left(\frac{8M_n \phi \lambda}{sL^2} \right) \quad (C3.1-1)$$

where:

w_{T-LRFD}	= total load required for fire design of wood member or assembly designed by LRFD method
α	= load factor on total load
M_n	= nominal moment capacity
ϕ	= LRFD resistance factor
λ	= LRFD time effect factor = 0.7 at calibration
s	= spacing of structural members
L	= span of structural members

From ASTM E119 Appendix X7:

$$\alpha = \frac{1.2w_D + 1.6w_L}{w_D + w_L} \quad (C3.1-2)$$

For wood members, the nominal moment capacity, M_n , can be related to the ASD moment capacity, M_{ASD} , as follows:

$$M_n = \frac{2.16}{\phi} M_{ASD} \quad (C3.1-3)$$

And:

$$M_{ASD} = \frac{(w_D + w_L)sL^2}{8} \quad (C3.1-4)$$

Substituting Equations C3.1-2, C3.1-3 and C3.1-4 into C3.1-1 provides the following equation:

$$w_{T-LRFD} = \frac{1.5(w_D + w_L)^2}{1.2w_D + 1.6w_L} \quad (C3.1-5)$$

Recognizing that $w_{T-LRFD} = w_{S-LRFD} + w_D$, the value of w_{S-LRFD} is estimated to be:

$$w_{S-LRFD} = \frac{1.5(w_D + w_L)^2}{1.2w_D + 1.6w_L} - w_D \quad (C3.1-6)$$

C3.1.3.4 Design loads: Where the fire-resistance rating is determined by calculation, the design load used for calculating the fire-resistance time for a wood member, wood assembly, or a wood connection is required to be determined in accordance with the NDS and the provisions of FDS 3.1.3.4.

Allowable Stress Design (ASD): For a wood member, wood assembly, or a wood connection designed using ASD methods, the total load (w_T) to be used to calculate the fire resistance time is calculated in accordance with FDS Equation 3.1-2. For simplicity, the design gravity live loads (w_L), include applicable occupancy live load, roof live load, and snow load, supported by the member or assembly. The load duration factor, C_D , associated with the load having the shortest load duration should be used in accordance with the NDS.

Strength Design (LRFD): Where a wood member, wood assembly, or a wood connection is designed using LRFD methods, the total load (w_{T-LRFD}) to be used to calculate the fire resistance time is calculated in accordance with FDS Equation 3.1-3, which is Equation C3.1-5 in the previous derivation of the total load required for fire design of a wood member or assembly designed by LRFD method in accordance with ASTM E119 Appendix X7.

C3.2 Charring of Wood

C3.2.1 Char Rate of Exposed Wood Members

Extensive one-dimensional char rate data is available for wood slabs. Two-dimensional char data is also available for timbers, but most of this data is limited to larger cross-sections. Evaluation of char rate models using one-dimensional char rate data suggests that charring of wood is nonlinear, and that estimates using linear models based on one-hour char rate data tend to underestimate char depth for short time periods (<60 minutes) and overestimate char depth for longer time periods (>60 minutes). To account for char rate nonlinearity, a nonlinear, one-dimensional char rate model, based on the results of 40 one-dimensional charring tests of wood slabs of various species, was developed by White [18].

This non-linear model addressed accelerated charring which occurs early in the fire exposure by applying a power factor to the char depth, a_{char} , to adjust for char rate nonlinearity:

$$t = m(a_{char})^{1.23} \quad (C3.2-1)$$

where:

- t = exposure time (hr.)
- m = char slope (hr./in.^{1.23})
- a_{char} = char depth (in.)

However, application of this model is limited since the char slope (hr./in.^{1.23}), m , is species-specific and limited data exists for different wood species fit to the model. In addition, the model is limited to one-dimensional slabs.

To develop a two-dimensional, nonlinear char rate model, the one-dimensional non-linear char rate model was modified to enable values for the slope factor, m , to be estimated using nominal char rate constants (in./hr.), β_n . The nominal char rate constant, β_n , is estimated using measured char depth at one hour. The non-linear char rate constant, β_i , is estimated from the nominal char rate constant, β_n as follows:

$$\beta_t = \beta_n \frac{(1 \text{ hr})}{(1 \text{ hr})^{0.813}} \quad (\text{C3.2-2})$$

where:

β_t = Non-linear char rate constant (in/hr^{0.813})

β_n = Nominal char rate constant (in/hr), linear char rate based on 1-hour exposure

C3.2.1.1 *Standard Char Rate*: For most wood and wood-based products, testing has confirmed that a non-linear char rate constant of $\beta_t = 1.5 \text{ in./hr}^{0.813}$, derived from an average nominal char rate, β_n , of 1.5 in./hr in accordance with Equation C3.2-2, which is evaluated at 1 hour, is applicable for softwood materials and conservative for hardwood materials.

C3.2.2 Char Depth, a_{char}

C3.2.2.1 For sawn lumber, structural glued-laminated softwood timbers, laminated veneer lumber, parallel strand lumber, and laminated strand lumber, the char depth can be directly estimated using FDS Equation 3.2-2 assuming a nominal char rate constant, β_n , of 1.5 inches/hr. The char depth, a_{char} , for each exposed surface can be calculated as:

$$a_{char} = \beta_t t^{0.813} = 1.5t^{0.813} \quad (\text{C3.2-3})$$

C3.2.2.2 Fall-off of charred or partially charred laminations was observed in early full-scale CLT fire tests, exposing the uncharred wood in the next layer. New adhesive requirements added to ANSI/APA PRG-320 [19] in 2019 require the adhesives to be qualified through fire testing intended to identify and exclude adhesives that permit char layer fall-off to an extent that it results in fire regrowth during the cooling phase of a compartment fire. The CLT char model in FDS 3.2.2.2 assumes that charred lamination fall-off occurs when the char front reaches the glueline. When this occurs, the non-linear char rate in Equation FDS 3.2-2 starts anew at $t = 0$ for the next lamination. To model the condition where the char layer falls off just as the char front reaches the glueline, the time required for the char front to reach the glueline for each lamination, $t_{gl,i}$, is calculated using FDS Equation 3.2-3.

The number of laminations fully charred in this model is calculated by subtracting each $t_{gl,i}$ from the total time until the last partial lamination is determined. The number of laminations charred completely through the depth, n_{lam} , is the largest truncated integer in which the following equation is true:

$$t - \sum_{i=1}^{n_{lam}} t_{gl,i} \geq 0 \quad (\text{C3.2-4})$$

The values of $t_{gl,i}$ and n_{lam} determined in the above equations are used to calculate the char depth, a_{char} , in FDS Equation 3.2-5a or 3.2-5b.

While the char fall-off model does not fully match the behavior observed during fire tests, comparison of this model to test data for CLT manufactured in accordance with ANSI/APA PRG-320-19 indicate that the estimated time for the char front to reach bond lines is reasonably well predicted by the model for most cases but may be quite conservative for certain cases (see C3.2.2.4).

C3.2.2.3 For CLT manufactured with laminations of equal thicknesses, the provisions of 3.2.2.2 can be simplified as provided in FDS 3.2.2.3.

C3.2.2.4 The provisions of 3.2.2.4 recognize that full-scale CLT testing has shown that wood laminations, bonded with adhesives meeting the adhesive requirements of the 2019 and later editions of ANSI/APA PRG-320, perform like solid wood except at abutting edges between laminations. Char penetration at abutting edges between laminations results in faster “apparent” char rates for CLT. In most cases, the CLT char provisions in FDS 3.2.2.2 and 3.2.2.3 can be used to conservatively estimate the char depth in CLT panels; however, in certain situations, use of these provisions can result in very conservative designs. While full-scale testing is an option, new models that incorporate the solid wood char depth provisions in FDS 3.2.2.1 and char penetration provisions in FDS 3.2.3, are being developed for use in these situations. Note that approval by the authority having jurisdiction is necessary in order to use analysis procedures permitted in FDS 3.2.2.4.

C3.2.3 Char Penetration at Intersections and Abutting Edges

Charring and char penetration begin almost immediately upon exposure of wood to elevated temperatures above 600°F. Char penetration at unbonded intersections and abutting edges between wood members results in deeper penetration of combustion temperatures and associated charring at these interfaces, as shown in Figure C3-1. As a result, where an interface between abutting wood members is tight or has a gap not exceeding 1/8 inch, and where air flow through the interface is prevented, charring is assumed to penetrate into the interface a distance that is approximately twice the char depth, $2a_{char}$, as shown in FDS Figure 3.1. Where a gap between exposed wood members is greater than 1/8 inch, or where air flow through an interface between wood members cannot be prevented, wood surfaces within the interface are assumed to be fully exposed to fire for the full depth and for the full fire exposure time.



Figure C3-1 Example of char penetration at abutting edges of CLT floor panels likely caused by gap formation due to bending deformation (photo courtesy of Katerra).

Because charring begins almost immediately when wood is exposed to combustion temperatures, there is insufficient time for an elevated temperature zone to form beyond the tip

of the char penetration. As a result, the char penetration into the gap does not need to be increased by the 1.2 factor used for structural calculations. The inner boundary of the elevated temperature zone is depicted by the red line in FDS Figure 3.1.

Gaps often exist at intersections and abutting edges of wood members due to manufacturing or construction tolerances and constructability requirements. Small gaps can also be created at intersections and abutting edges that are initially considered to be in contact due to shrinkage, excessive bending deformations, or differential movement. Recognizing that the char front can penetrate these small gaps, the provisions of FDS 3.2.3.1 through 3.2.3.4 provide means of calculating the char penetration as illustrated below.

C3.2.3.1 Intersections and abutting edges of exposed members that are protected on the exposed side with an approved fire-resistant joint system (see Figure C3-2):

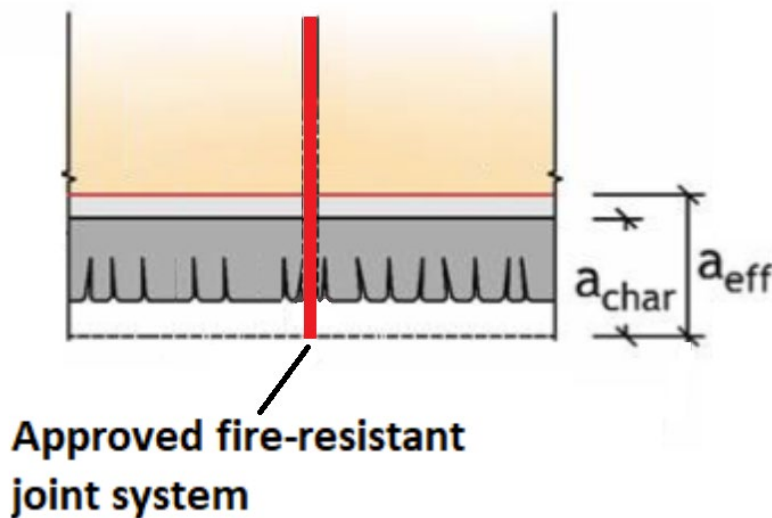

Figure C3-2 Example showing approved fire-resistant joint system on the exposed side

C3.2.3.2 Intersections and abutting edges of exposed members that are in contact or have gaps less than or equal to 1/8 inch and where air flow through gaps is permitted to be neglected using one of the options in FDS 3.2.3.2 (see Figure C3-3):

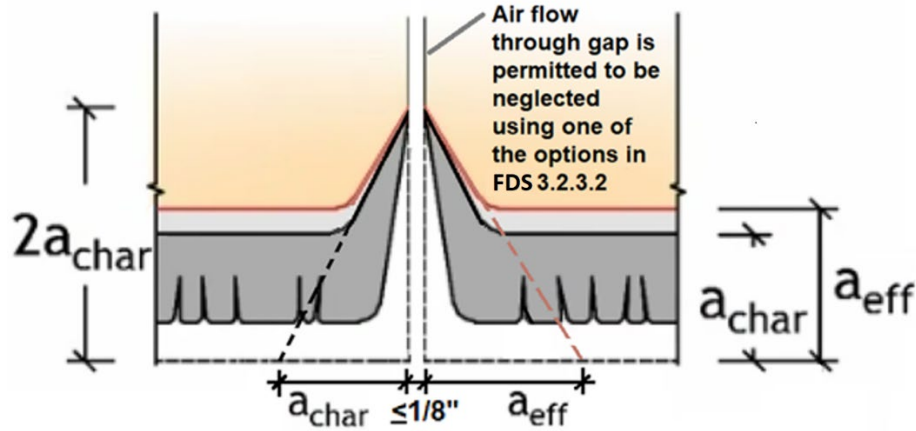

Figure C3-3 Example showing char penetration where gap is less than or equal to 1/8-inch on the exposed side and where air flow through gap is permitted to be neglected

C3.2.3.3 Intersections and abutting edges of exposed members that are in contact or have gaps less than or equal to 1/8 inch but air flow through gaps is not permitted to be neglected (see Figure C3-4):

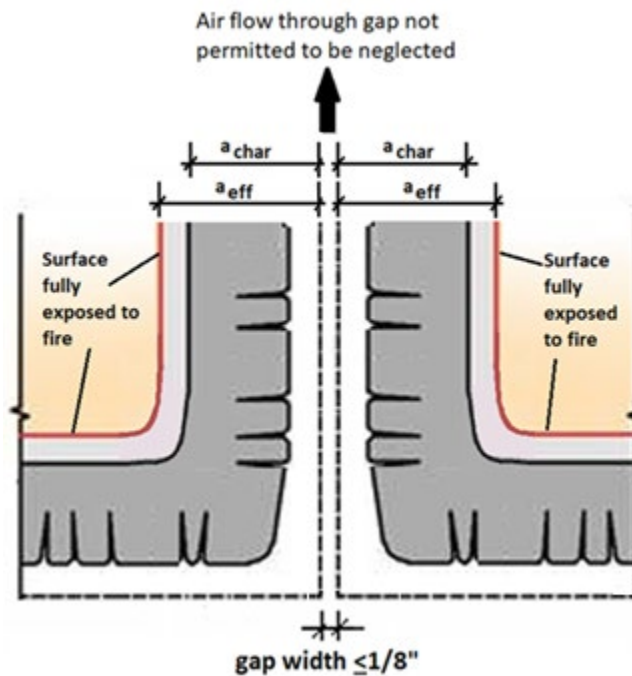

Figure C3-4 Example showing char penetration where gap is less than or equal to 1/8-inch on the exposed side and where air flow is not permitted to be neglected

C3.2.3.4 Intersections and abutting edges of exposed members that have gaps greater than 1/8-inch (see Figure C3-5):

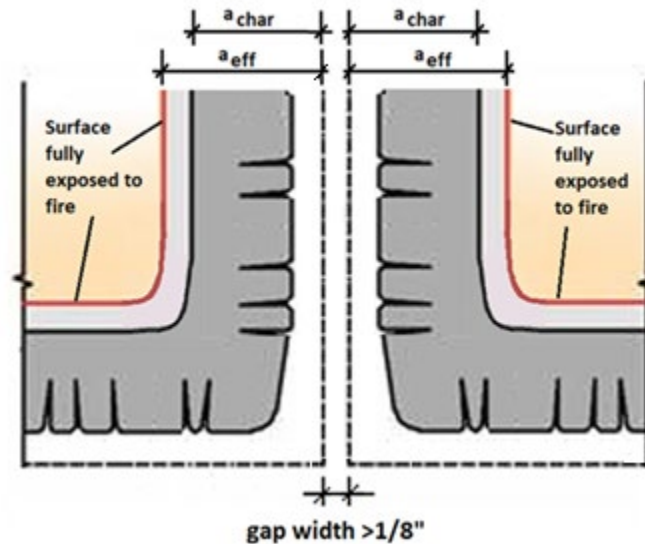

Figure C3-5 Example showing char penetration where gap is greater than 1/8-inch on the exposed side

C3.3 Structural Fire Resistance of Exposed Wood Members

The mechanics-based design procedures in this Specification for exposed wood members are based on research described in AWC's *Technical Report 10: Calculating the Fire Resistance of Exposed and Protected Wood Members* (TR10) [17]. The design procedure calculates the capacity of exposed wood members using basic wood engineering mechanics. Section properties are computed assuming an effective char depth, a_{eff} , at a given time, t . Reductions of strength and stiffness of wood in the heated zone adjacent to the char layer are accounted for by assuming the effective char depth, a_{eff} , is equal to 1.2 times the char depth, a_{char} . Average member strength properties are approximated from accepted procedures used to calculate design properties. Finally, wood members are designed using accepted engineering procedures found in NDS for allowable stress design. The design procedures presented in this Standard are not intended to evaluate wood members for continued use after a fire event. Although the design provisions of FDS Chapter 3 are limited to calculated fire-resistance ratings not exceeding 2 hours for exposed wood members, calculated fire resistance times are permitted to exceed 2 hours for protected wood members and wood assemblies, provided the calculated fire-resistance contribution of the wood member itself does not exceed 2 hours.

C3.3.1 Effective Char Depth, a_{eff}

For structural calculations, section properties are calculated using dimensions which have been reduced due to charring perpendicular to each surface exposed to fire. The dimensions are reduced by the effective char depth, a_{eff} , calculated in accordance with FDS Equation 3.3-1 which is 20% greater than the actual char depth, a_{char} , calculated in FDS 3.2.2, except for specific bearing conditions addressed in FDS 3.3.1.4 which use an effective char depth of 50% greater

than a_{char} . The increases account for strength and stiffness loss in the elevated temperature zone ahead of the char front.

C3.3.1.1 For sawn lumber and timbers, structural glued-laminated softwood timbers, laminated veneer lumber (LVL), parallel strand lumber (PSL), and laminated strand lumber (LSL), section properties can be calculated using a_{eff} , (determined from FDS Equations 3.2-2 and 3.3-1) and standard equations for area, section modulus, and moment of inertia using reduced cross-sectional dimensions. Equations for calculating cross-sectional properties for rectangular members exposed on all four sides are shown in Table C3.3-1. Section properties corresponding to other exposure configurations (e.g., three-sided exposure of a beam) can be calculated using a similar method.

Table C3.3-1 Cross-Sectional Properties for Four-Sided Exposure

Cross-sectional Property	Four-Sided Exposure Example
Area of the cross-section, in ²	$A(t) = (D_{min} - 2a_{eff})(D_{max} - 2a_{eff})$
Section Modulus about major-axis (XX), in ³	$S_{XX}(t) = (D_{min} - 2a_{eff})(D_{max} - 2a_{eff})^2/6$
Section Modulus about minor-axis (YY), in ³	$S_{YY}(t) = (D_{min} - 2a_{eff})^2(D_{max} - 2a_{eff})/6$
Moment of Inertia about major-axis (XX), in ⁴	$I_{XX}(t) = (D_{min} - 2a_{eff})(D_{max} - 2a_{eff})^3/12$
Moment of Inertia about minor-axis (YY), in ⁴	$I_{YY}(t) = (D_{min} - 2a_{eff})^3(D_{max} - 2a_{eff})/12$

C3.3.1.2 For cross-laminated timbers, reduced cross-section dimensions are calculated using a_{eff} (determined from FDS Equation 3.2-5a or 3.2-5b and FDS Equation 3.3-1); however, due to the complex interactions of crossing laminations and proprietary nature of cross-laminated timber layups, the effect of charring on the capacity of a specific CLT product should be checked with the manufacturer. Alternatively, the capacity of the charred cross-laminated timber can be conservatively estimated by limiting the fire design capacity to that of a panel with the same number of full-depth laminations remaining in the axis being considered after a given fire resistance time. For example, for CLT layups in Annex A of APA PRG 320, the cross-laminated timber is permitted to be designed using properties for one of the tabulated CLT layups in Annex A where the number of laminations does not exceed the number of uncharred laminations remaining after laminations affected by the effective char depth, from FDS Table 3.3.1.3, have been subtracted.

C3.3.1.3 *Effective Char Depth for Bearing.* Design requirements for calculating the effective char depth at bearing interfaces, $a_{eff(bearing)}$ are based on recent research that suggests that larger reductions are required in perpendicular-to-grain bearing areas.

Unlike most wood properties, strength and stiffness properties of wood loaded in compression perpendicular-to-grain are particularly sensitive to high moisture at approximately 212°F (100°C). These strength and stiffness properties are estimated to be only 20% of the initial strength and stiffness at 212°F, as reported by Gerhards [32].

Thermocouple data from full-scale tests of a large wood beam bearing on a wood column were analyzed. In that study, moisture in the form of steam, likely from moisture within the heated wood column, was driven toward the bearing interface between the beam and column, subjecting large areas of the wood fibers on the bearing face of the wood beam to high moisture levels and at temperatures of around 212°F.

Over time, this area grew much faster than the char depth from the fire exposure as shown in Figure C3-6, where the orange area represents wood that below 170°F, the blue area represents wood that is between 170°F and 260°F (which includes wood at or above the temperature of steam), the purple area represents wood that is between 260°F and 530°F (which includes wood in the elevated temperature zone above 260°F), the black area represents wood that is above 530°F (which includes wood that has charred).

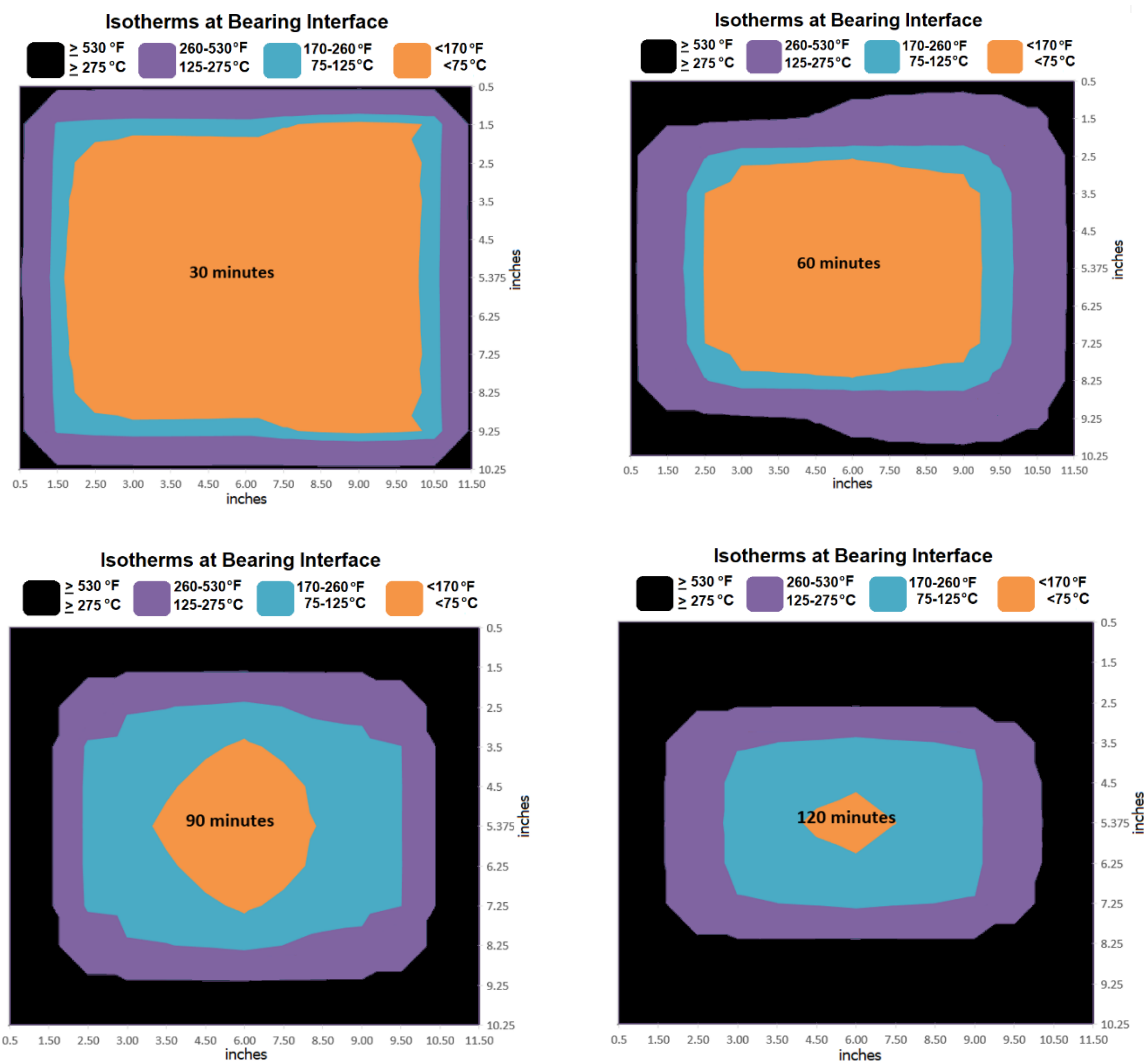

Figure C3-6 Isotherms at Bearing Interface

Based on this thermocouple data, a regression was developed to predict the depth of the 212°F isotherm relative to a_{char} . The depth of the 212°F isotherm was estimated to be at a depth of $1.6a_{char}$ ahead of the char front.

To maintain the same fire design methodology that is used for other properties in the FDS, an increase in the char depth, a_{char} was developed to provide an effective char depth for bearing perpendicular to grain, $a_{eff(bearing)}$, to account for loss of strength and stiffness for this bearing

condition. Recognizing that the standard equation in FDS 3.3.1 for determining the effective char depth, a_{eff} , assumes zero strength in the elevated temperature zone estimated to precede the char front by 20%, and assuming 20% strength in the remaining area between the 212°F isotherm and the $1.2a_{\text{char}}$ depth, $a_{\text{eff(bearing)}}$ is estimated using Equation C3.3.1.3:

$$a_{\text{eff(bearing)}} = a_{\text{char}} [(1.6-1.2)(1-0.2)+1.2] = 1.5a_{\text{char}} \quad (\text{Equation C3.3.1.3})$$

In loadbearing applications, a few small gaps may exist as a result of misalignment or fabrication tolerances; however, significant gaps that would affect the bearing capacity are assumed to close as the bearing stress increases from reductions in the bearing area and as the stiffness and strength of wood in the bearing area decrease due to increased temperature and moisture. As a result, $a_{\text{eff(bearing)}}$ is assumed to be the limiting case for bearing interfaces, rather than $2a_{\text{char}}$ (see FDS 3.2.3), in these configurations.

The requirement for use of sealants to reduce char penetration into bearing areas was removed in the 2024 FDS. Testing has not demonstrated a structural benefit for sealants in this application. Sealants may otherwise be required by the building code to resist passage of hot gases at intersections which is addressed in FDS 1.7.8 and specific requirements in FDS 3.2.3.1 and 3.2.3.2.

C3.3.2 Member Strength

To approximate an average member strength using a reference design value, the reference design value from the NDS is multiplied by an adjustment factor, K . For all properties except compression perpendicular-to-grain, $F_{c\perp}$, the K factor adjusts the allowable design value, based on a 5% exclusion value, to an average ultimate value [17]. For bending, F_b^* is multiplied by the adjustment factor, K , prior to calculation of the beam stability factor, C_L , from the NDS. Similarly, F_c^* is multiplied by the adjustment factor, K , prior to calculation of the column stability factor, C_P , in the NDS.

Footnotes to FDS Table 3.3.2 clarify that the beam stability factor, C_L , and column stability factor, C_P , are calculated using the reduced dimensions of the member at the end of the fire exposure. Conversely, the size factor, C_F , volume factor C_V , and flat use factor, C_{fu} are calculated using the initial dimensions of the member.

The adjustment factor, K , has two components, the inverse of the applicable design value adjustment factor, $1/k$, and the inverse of the variability adjustment factor, c . To develop general design procedures for sawn lumber, structural glued laminated softwood timber, laminated veneer lumber, parallel strand lumber, laminated strand lumber, and cross-laminated timber, design value adjustment factors and estimates of design property COV were used to conservatively develop an allowable design stress to average ultimate strength adjustment factor, K , for each design property as shown in Table C3.3-2.

Since $F_{c\perp}$ reference design values are derived from deformation-based test values, the design values do not represent ultimate strength. Ultimate strength in compression perpendicular-to-grain is not well defined; however, ASTM D5457 [30] sets the Format Conversion Factor, K_F , equal to 1.67 for

adjusting reference ASD $F_{c\perp}$ design values to nominal resistances for use with LRFD. This factor was deemed appropriate for design of wood members exposed to fire. Where fire exposure increases the aspect ratio of the cross section, the potential for buckling perpendicular-to-grain should also be considered.

Table C3.3-2 ASD Reference Value to Average Ultimate Strength Adjustment Factors

	F	$1/k$	c	Assumed COV	K
Bending Strength	F_b	2.1 ¹	1-1.645 COV _b	0.16 ²	2.85
Tensile Strength	F_t	2.1 ¹	1-1.645 COV _t	0.16 ²	2.85
Shear Strength	F_v	2.1 ¹	1-1.645 COV _v	0.14 ²	2.75
Compression Strength	F_c	1.9 ¹	1-1.645 COV _c	0.16 ²	2.58
Buckling Strength	E_{05}	1.66 ⁴	1-1.645 COV _E	0.11 ⁵	2.03
Bearing Strength	$F_{c\perp}$	1.67 ⁶	1.0 ⁷	<mean value>	1.67

¹ taken from Table 8 of ASTM D245 *Standard Practice for Establishing Structural Grades and Related Allowable Properties for Visually Graded Lumber* [20], Table 1 of ASTM D3737 *Standard Practice for Establishing Allowable Properties for Structural Glued Laminated Timber (Glulam)* [21], and Table 1 of ASTM D5456 *Standard Specification for Evaluation of Structural Composite Lumber Products* [22].

² taken from Table 5-6 of 2010 *Wood Handbook* [23] for clear wood bending values.

³ taken from Table 5-6 of 2010 *Wood Handbook* for clear wood shear values.

⁴ taken from Appendices D and H of 2024 *National Design Specification for Wood Construction*.

⁵ taken from Appendix F of 2024 *National Design Specification for Wood Construction*.

⁶ taken from Table 2 of ASTM D5457 *Standard Specification for Computing Reference Resistance of Wood-Based Materials and Structural Connections for Load and Resistance Factor Design*.

⁷ $F_{c\perp}$ is a mean-based value, so no adjustment for COV should be made.

C3.3.3 Design of Members

For fire design, the induced forces and moments cannot exceed the average member capacity of a wood member exposed to fire for a given time, t . The average member capacity is estimated using cross-sectional properties reduced for fire exposure in accordance with FDS 3.3.1 and average ultimate strength properties derived from reference design values determined in accordance with FDS 3.3.2.

C3.3.3.1 Special Provisions for Lumber Decking: Sides of individual lumber decking members are shielded from full fire exposure by adjacent members. Partial exposure occurs as decking members shrink and gaps form between the decking members. The degree of exposure is a function of the view angle of the radiant flame and the ability of hot volatile gases to pass through the gaps. See C3.2.3 for fire design of abutting edges of exposed lumber decking.

When gaps between mechanically-laminated decking are obstructed, as when the decking is topped with wood structural panels or continuous topping, the decking can be designed using the provisions of FDS 3.2.3.2 with dimensions as shown in Fig C3-7.

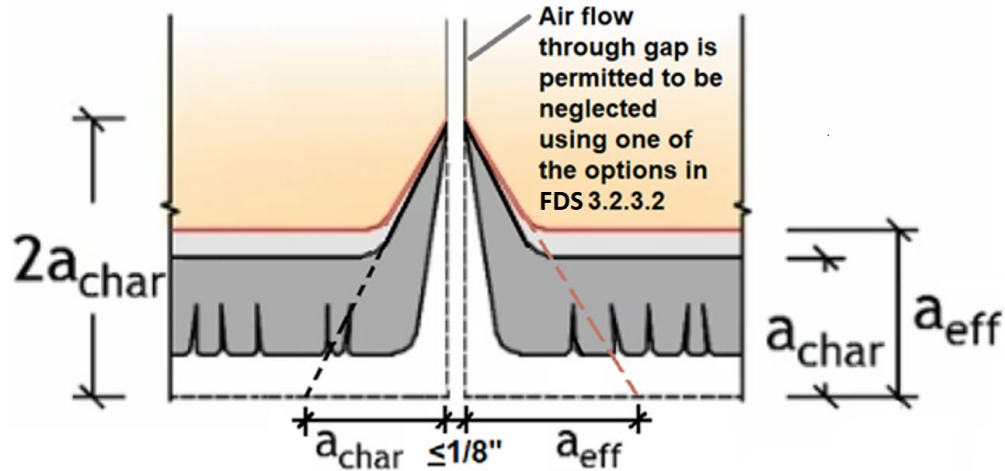

Figure C3-7 Example showing char penetration for decking where gaps are obstructed

When gaps between mechanically-laminated decking are unobstructed, such as can occur when the decking is untopped, hot gases will pass through the gaps, and the sides of the decking members will char. This charring can be approximated assuming the sides of a member, char to a depth of a_{eff} with dimension as shown in Figure C3-8.

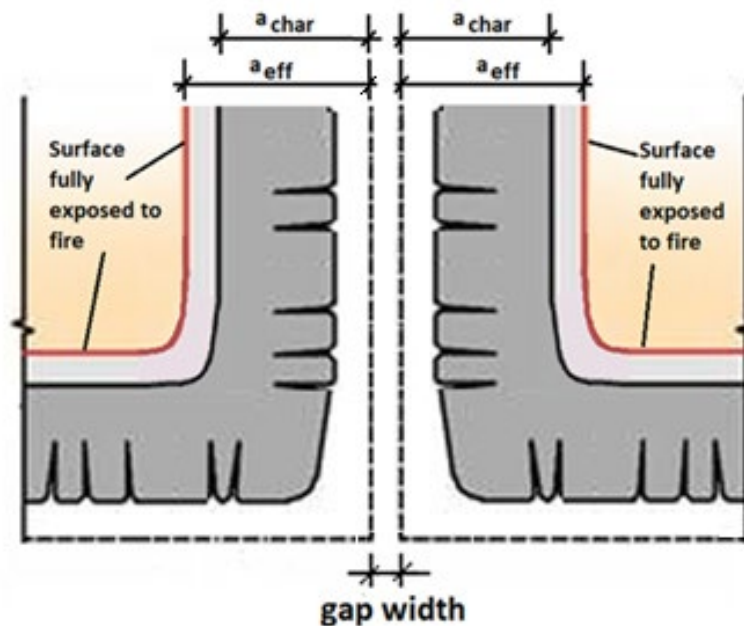

Figure C3-8 Example showing char penetration for decking where gaps are unobstructed

Exceptions:

1. For intersections which are not open, as with single and double tongue-and-groove timber decking, tests have shown that charring of the sides of members is negligible and can be ignored

and, therefore, are permitted to be designed as an assembly of wood beams fully exposed only on the bottom face.

2. When gaps between mechanically-laminated decking are obstructed to prevent passage of hot gases, such as where the decking is topped with wood structural panels or a continuous topping, tests have shown that the char depth on the sides of the pieces can be conservatively approximated assuming a partial exposure char rate, such that the sides char to a depth of $a_{eff}/3$. This approach becomes increasingly conservative as the depth of the decking increases.

C3.3.3.2 Special Provisions for Structural Glued Laminated Timber Beams: The outer laminations of glued laminated timber bending members in Table 5A of the NDS Supplement [24] are typically higher strength laminations. When the beam is exposed to fire from either the bottom or from the top and bottom of the beam, these laminations are the first to be charred. In order to maintain the ultimate capacity of the beam when these laminations are completely charred, additional laminations having the same grade as the outer laminations must be added to the beam layup with a corresponding number of lower grade core laminations removed. For beams with the top surface protected from fire, only the bottom of the beam is required to be modified. For beams with both the top and bottom surfaces exposed, both the top and bottom of the beam are required to be modified.

C3.4 Protection of Structural Wood Members and Wood Assemblies

Where protective materials are used to increase the fire resistance of structural wood members, the structural fire resistance times of protected wood members are calculated in accordance with the provisions of exposed wood members in FDS 3.2; however, fire exposure and calculation of charring of each protected surface is delayed by the protection time, t_p . The value of t_p , for the protective material, is the delay of the onset of charring of the protected surface and is permitted to be determined either by testing or using assigned values and calculations in accordance with FDS 3.4. Where all surfaces of a structural wood member are protected with a protection system, such as when protected on the fire exposure side by one or more protective membranes, the protection time of the protection system is directly additive with the structural fire resistance time of the structural wood member calculated for the exposed wood member in FDS 3.2.

C3.4.1 Protection by Wood

The protection time assigned to wood cover is equal to the time required to char through the wood cover. These calculations do not account for damage that may occur in the protected member due to elevated temperatures ahead of the char front, resulting in less total thickness than would be required for a single solid piece oversized with a sacrificial layer of wood in accordance with 3.3.1. Where wood cover is used to protect a structural member to avoid any significant strength or stiffness loss, the protection time, t_p , should be multiplied by 0.85.

C3.4.1.1 Wood cover in contact with protected member: Testing of single layer and multi-layer wood cover [25] has shown that char-through time, t_p , can be estimated with the non-linear char rate equations in FDS 3.2.2, which have been restructured to provide FDS Equations 3.4-1 and 3.4-2.

C3.4.1.2 *Wood cover not in contact with protected member*: Testing suggests that a single layer of protection that is unbacked by additional material chars faster. This accelerated charring is likely due to loss of moisture and introduction of fresh air from the unexposed surface [25]. FDS Equations 3.4-3a and 3.4-3b were derived to model this accelerated char which averaged approximately 2.1 in./hr (17 minutes for the last 0.6 in. of the protection thickness).

C3.4.1.3 *Wood membrane*: Where wood cover is used as a membrane, such as wood structural panels protecting a wood assembly, t_p is estimated using either the provisions of FDS 3.4.1.1 or 3.4.1.2 depending on whether the wood cover is in contact with the protected surfaces or not. Note that, since the wood cover is acting as a membrane, the protection time calculated in FDS 3.4.1.1 or FDS 3.4.1.2 is directly additive with protection times from Type X gypsum panel membranes and/or insulation membranes and with the structural fire resistance time of the structural wood member calculated for the exposed wood member in FDS 3.2.

C3.4.1.4 *Fasteners attaching wood protection*: Assuming a fastener tip length of 1/4 inches, (2 diameters for common fasteners per NDS 12.3.5.3b) and zero fastener holding strength in the char layer of the protected member, a minimum penetration of 1 inch would hold the charred wood protection in place for approximately 25 minutes after the char front has moved beyond the protection..

$$t = 60 \left(\frac{1-0.25}{1.5} \right)^{1.23} = 25 \text{ minutes} \quad (\text{C3.2-4})$$

C3.4.1.5 *Intersections and abutting edges of exposed wood cover*: Where char penetration will cause gaps to form between wood members and wood cover, or between wood cover elements that are initially considered to be in contact, see C3.2.3 for calculation of depth of char penetration into these gaps.

C3.4.2 Protection by Type X Gypsum Panel Products

C3.4.2.1 *Gypsum panel cover*: Testing of single layer and multi-layer of Type X gypsum panels has shown that t_p can be consistently estimated [25][26]. The protection provided by two thicknesses of Type X gypsum board that have been extensively tested are documented in TR10 and provided in FDS Table 3.4.2.1.

C3.4.2.2 *Gypsum panel membrane*: Where Type X gypsum panels are used as a membrane to protect a wood member or wood assembly, t_p is estimated using the provisions of FDS 3.4.2.2. Note that, since the gypsum panel is acting as a membrane, the protection time calculated in FDS 3.4.2.2 is directly additive with protection times from wood and/or insulation membranes and with the structural fire resistance time of the structural wood member calculated for the exposed wood member in FDS 3.2. For wall assemblies, fastener configurations with specified screws and spacings closer than those tabulated in FDS 3.4.2.1 have been shown to increase the protection time provided by the gypsum panel membrane see FDS Table 3.4.2.1 footnotes (7, 8 and 9); however, this benefit has not been observed in testing of floor-ceiling and roof-ceiling assemblies.

C3.4.2.3 *Fasteners attaching gypsum panel products*: Assuming a fastener tip length of 1/4 inches, (2 diameters for common fasteners per NDS 12.3.5.3b) and zero fastener holding strength in the char layer of the protected member, a minimum penetration of 1 inch would hold the charred wood protection in place for approximately 25 minutes after the char front has moved beyond the protection.

C3.4.2.4 Gypsum panel product contraction: Small-scale tests have shown that both regular and Type X gypsum board shrink very little until the gypsum board reaches a temperature of about 600°F. Shrinkage (contraction) increases slightly between 600°F and 850°F, slows between 850°F and 1650°F, then increases rapidly above 1650°F [27] (see Figure C3-4). The various stages of thermal contraction indicate chemical decomposition of the gypsum. Given that the E119 time – temperature curve reaches 1000°F in the first 5 minutes of the test, it can be assumed that the surface of gypsum panel products on the fire exposed side of the gypsum panel also reaches 1000°F in 5 minutes. Measurements of “finish ratings” of wood-frame assemblies protected with gypsum panel products (a finish rating is the time at which the wood stud or wood joist reaches an average temperature rise of 250°F or an individual temperature rise of 325°F as measured on the plane of the wood nearest the fire under the protection) suggest that the temperatures on the unexposed side of the gypsum panel at the finish rating time would be approximately 325-400F (assuming initial temperature of approximately 75°F at the start of the test). Assuming a linear temperature gradient through the gypsum panel, the average temperature in the gypsum panel, at the finish rating time would be approximately 650-700F, which is the point at which the first stage of significant thermal contraction occurs in gypsum, as shown in Figure C3-9. Thermal contraction in gypsum panels is responsible for the development of cracks and fissures in the gypsum panel, as well as the formation of gaps at the ends and edges of the gypsum panel that are initially in contact. A conservative estimate of the time at which gypsum panel contraction begins to form gaps at ends and edges of gypsum panels, which is initially tightly fitted, is at the finish rating time of the assembly, or approximately 50% of the protection time provided by the gypsum panel (see FDS 3.6.2.1).

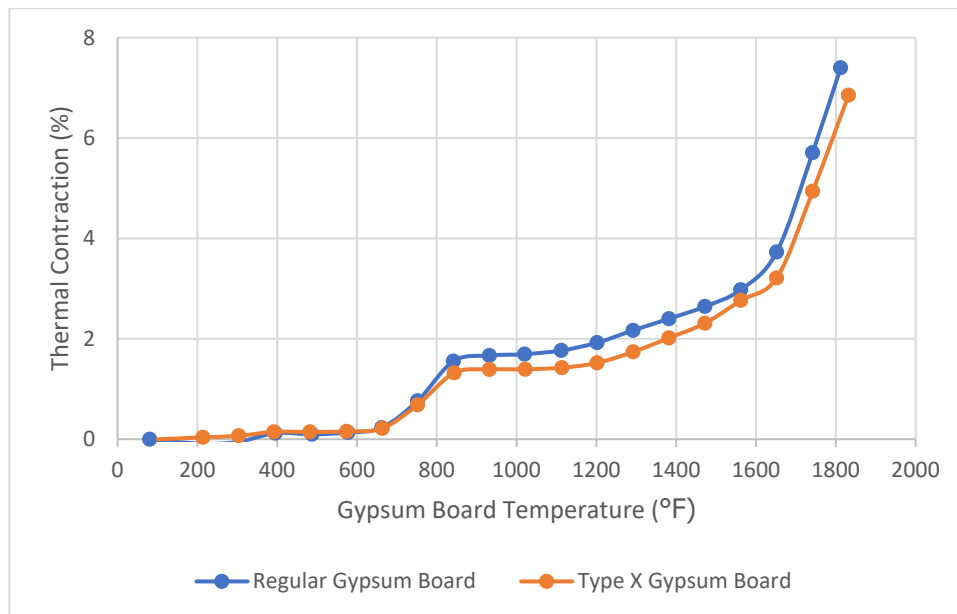

Figure C3-9. Thermal Contraction of Gypsum Board

C3.4.3 Protection by Insulation

C3.4.3.1 Insulation cover: Relative comparisons of E119 test data have been used to develop t_p values for two common insulation products; mineral wool batts with a minimum nominal density of 2.5 pcf and ranging from 1.5 inches thick to 5.5 inches thick and fiberglass batts ranging from 3.5 in. thick R-13 batts to 6.25 in. thick R-19 batts compressed to 5.5-inch thickness (see TR10). In general, mineral wool batts of 3.5 inches and thicker provided

approximately 19 minutes of protection, but 1.5 inches thick mineral wool batts provided slightly less protection at $t_p=15$ minutes. For fiberglass batts, there was no significant difference between R-13 (3.5 inches thick) batts and R-19 (5.5 inches thick) batts, both providing $t_p=3$ minutes. Because thicknesses of mineral wool insulation and fiberglass insulation greater than 3.5 inches did not provide increased protection times, the tabulated protection times specified in FDS Table 3.3.3.1 are not to be additive with each other and should not be increased for additional insulation thickness, density, or R-value without additional testing.

C3.4.3.2 Insulation as part of a membrane: Like other materials used as protection, where mineral wool or fiberglass insulation are used as part of a membrane to protect the entire wood member or wood assembly, the protection time calculated in FDS 3.4.3.1 is directly additive with protection times from wood and/or gypsum panel membranes and the structural fire resistance time of the structural wood member calculated for the exposed wood member in FDS 3.2.

C3.5 Calculation of Structural Fire Resistance Time of Protected Wood Members and Wood Assemblies

Protection of wood members or assemblies delays the onset of charring on each protected surface. The delay can range from a few minutes to several hours. The structural fire resistance time for protected wood members and assemblies can be calculated in accordance with the provisions for exposed wood member in FDS 3.2, accounting for delayed charring on each protected surface when calculated in accordance with FDS 3.4. The provisions for calculating the structural fire resistance time for a structural member is limited to charring for up to 2 hours, but when a surface is protected, that 2-hour limit starts after the delay of charring on that surface. When exposure of a member or assembly is delayed on all surfaces, as by a protective membrane, the 2-hour limit can be extended by the protection time.

C3.6 Calculation of Thermal Separation Time

The thermal separation time is defined as the time at which an average temperature rise of 250°F or an individual temperature rise of 325°F is reached on the unexposed side of the wood assembly. The thermal separation time of a wood assembly can be determined by testing in accordance with ASTM E119 or UL 263 or by calculation. When determined by calculation following the procedures of FDS 3.6, thermal separation can be estimated by summing the times assigned to the protective membranes on both the fire-exposed side of the assembly and the unexposed side of the assembly, and additional contribution by other protective components in the assembly, such as insulation. During testing or by calculation, if the structural fire resistance time occurs before the thermal separation time is reached, the thermal separation time is limited to the structural fire resistance time since the structural assembly is assumed to hold the protective membranes in place.

C3.6.1 Thermal Separation Time Provided by Wood Layers

C3.6.1.1 Wood cover or membranes: Testing has shown that the contribution of wood layers to the thermal separation time is equal to the sum of protection times assigned to each layer, determined in FDS 3.4.1, except where a single layer of wood is used to provide thermal

separation or where the final layer is located on the unexposed side of the thermal separation is wood, the time assigned to that wood layer, as determined in FDS 3.4.1, should be multiplied by 0.85 [17][18]. The 0.85 factor limits the temperature rise on the backside of the last layer of wood to an average temperature rise of 250°F.

C3.6.2 Thermal Separation Time Provided by Type X Gypsum Panel Products

C3.6.2.1 Gypsum panel cover or membranes: Testing has shown that the contribution of Type X gypsum panel layers to the thermal separation time is equal to the sum of protection times assigned to each layer as determined in FDS 3.4.2, except that the time assigned to the last Type X gypsum panel layer, is multiplied by 0.50 [17][18]. The 0.50 factor limits the temperature rise on the backside of the last layer of Type X gypsum panel to an average temperature rise of 250°F and is a conservative estimate of the “finish rating”. See C3.4.2.4 for discussion of the “finish rating”.

C3.6.2.2 Gypsum panel product contraction: Where Type X gypsum panel contraction will cause gaps to form between adjoining gypsum panels that are initially considered to be in contact, limited ignition of combustible materials directly behind the gaps will likely occur at the time assigned to that Type X gypsum panel layer, determined in FDS 3.4.2, multiplied by 0.50; however, the effect on the thermal separation time, estimated in FDS 3.6.2.1, is permitted to be ignored since the impact on the wood assembly is typically only limited to ignition of the wood directly behind the gap and doesn't impact the overall wood assembly. See C3.4.2.4 for discussion of gypsum panel product contraction.

C3.6.3 Thermal Separation Time Provided by Insulation

C3.6.3.1 Insulation protection time: Testing has shown that the contribution of insulation within an assembly to the protection time can be directly added to the thermal separation time, determined in FDS 3.3.3, since the location where limiting temperature rise for thermal separation is measured is not on the surface of the insulation. If an unconventional assembly were developed that measured the temperature rise on the unexposed side of the insulation, the contribution of the insulation may need to be limited. Because thicknesses of mineral wool insulation and fiberglass insulation greater than 3.5 inches did not provide increased protection times, the tabulated protection times specified in FDS Table 3.4.3.1 are not intended to be additive with each other and should not be increased for additional insulation thickness, density, or R-value without additional testing (see also C3.4.3).

C3.7 Calculation of Burn-Through Time

Burn-through time between wood members or through wood assemblies must be determined for wood assemblies tested or designed to meet the thermal separation requirements of ASTM E119 or UL 263. Burn-through time of wood assemblies is typically limited by char penetration between the wood members or wood cover or by Type X gypsum panel product contraction between the gypsum panels on the unexposed side of the wood assembly. Char penetration can be estimated using the provisions of FDS 3.6.1.2. Gypsum panel product contraction can be estimated using the provisions of FDS 3.6.2.2. Typically, burn-through is addressed by detailing adequate protection to ensure that gaps on the unexposed side of the assembly do not occur before the required structural fire resistance time or the thermal separation time is reached.

C3.8 Tested Fire-Resistance-Rated Assemblies

Selected wood assemblies, tested in accordance with ASTM E119 or UL 263, are provided in FDS Supplement B as a reference to designers. These tested assemblies can be used directly since they were tested in accordance with the code-referenced test standards and meet the specified fire-resistance ratings.

C3.9 Component Additive Method for Assemblies

FDS 3.9 provides a new Component Additive Method for determining the fire-resistance ratings of wall assemblies, floor/ceiling assemblies, and roof/ceiling assemblies. The provisions are based on analysis of test data from wood assemblies tested in accordance with ASTM E119, UL 263, ISO 834 [28], and ULC S101 [29] as reported in TR10 [17] and calculations in accordance with FDS 3.1 through 3.7.

C3.9.1 Calculating the Structural Fire Resistance Time

The structural fire resistance times of wood assemblies in FDS 3.9.1 are based on structural fire resistance times for the structural members calculated per provisions of FDS 3.2 [17] and the protection times assigned to protective membranes on the fire-exposed side in accordance with FDS 3.4. For ease of use, typical structural fire resistance times for the structural members are provided in FDS 3.9.1.1 and typical protection times assigned to protective membranes are provided in FDS 3.9.1.2. Because these wood assemblies are wood structural members protected with membranes, the structural fire resistance time is the sum of the structural fire resistance time assigned to the members (FDS 3.9.1.1) and the membrane protection time (FDS 3.9.1.2). Note that since insulation may only protect certain surfaces, especially in more complex shapes such as wood I-joists, the contribution of insulation is included in the tabulated structural fire resistance times for the structural members. Insulation, where required for member protection, should fill the cavities between wall studs or be placed between joists or trusses at the ceiling side of horizontal assemblies. The membrane on the unexposed side does not contribute to the structural fire resistance time of the assembly, so it should not be included in the calculated structural fire resistance time; however, the membrane on the unexposed side of the assembly may be required to provide lateral bracing to the structural wood members after degradation of the membrane on the exposed side.

C3.9.1.1.1 *Sawn Lumber, LVL, PSL, or LSL Studs*: The structural fire resistance times for studs in FDS Table 3.9.1.1.1 are calculated using the provisions from FDS 3.2 for wood members exposed on 3 sides and assuming an initial concentric compression load for each stud limited as a percentage of either the maximum bearing (ASD adjusted compression perpendicular to grain stress, F_c^\perp , at the stud to plate bearing) or the maximum axial compression (ASD adjusted compression parallel to grain stress, F_c' , for an individual stud) with an unbraced length of 115.5 inches (a wall height of 120 inches minus the thickness of three 1.5 inch thick wall plates) and a buckling length coefficient, $K_e = 1.0$. Tabulated values in FDS Table 3.9.1.1 are based on common ratios of maximum bearing or axial compression typically used in testing. During E119 fire tests of walls with membranes on both faces, it has been observed that structural failure occurs when the studs buckle out of the furnace in the strong axis due to charring of the edge of studs on the exposed side of the assembly creating eccentric loading. To model this behavior using the provisions of FDS 3.2, the stress interaction in NDS 15.4.1 is calculated assuming an eccentricity, $e = a_{char}/2$ and $K_e = 0.7$ to simulate square-cut bearing on the wood plates. The delay in charring on the sides of the studs when insulation is present is addressed in the model and represented in the tabulated values. For more information, see TR10.

C3.9.1.1.2 *Sawn Lumber, LVL, PSL, or LSL Joists*: The structural fire resistance times for rectangular joists in FDS Table 3.9.1.1.2 are calculated using the provisions from FDS 3.2 for wood members exposed on 3 sides and assuming full lateral bracing of the compression edge and a uniform load for each joist expressed as a ratio of the induced stress to the maximum ASD adjusted bending stress, F_b' . The delay in charring on the sides of the joists when insulation is present is addressed in the model and represented in the tabulated values. For more information, see TR10. While the tabulated times are based on ratios of f_b/F_b' , for cases where f_v/F_v' controls the design, the tabulated fire resistance time for a given stress ratio is slightly conservative for all cases.

C3.9.1.1.3 *Wood I-Joists*: The structural fire resistance times for wood I-joists in FDS Tables 3.9.1.1.3a and 3.9.1.1.3b are calculated using the provisions from FDS 3.2 for wood members exposed on multiple surfaces and assuming a uniform load for each I-joist limited to the maximum bending capacity provided by the manufacturer. The maximum bending capacity is based on the ASD adjusted moment capacity for given flange dimensions and the maximum shear capacity is based on the ASD adjusted shear capacity for a given web thickness. The structural fire resistance time is the minimum resistance time assigned to the flange and the web in FDS Tables 3.9.1.1.3a and 3.9.1.1.3b, respectively. The delay in charring on protected surfaces of the I-joists when insulation is present is addressed in the model and represented in the tabulated values. For more information, see TR10.

The structural fire-resistance times assigned for wood I-joists based on flange dimensions can be conservatively applied for joists with larger flange sizes. Alternatively, times for other flange sizes can be determined based on calculations using the procedures of FDS 3.5.

C3.9.1.3 *Protection of Wood Members*: The added fire protection times in FDS Table 3.9.1.2a for a wood membrane(s) are based on FDS 3.4.1.3. The added fire protection times in FDS Table 3.9.1.2b for a Type X gypsum panel membrane(s) are based on the FDS 3.4.2.2.

C3.9.2 Calculating the Thermal Separation Time

The provisions of FDS 3.9.2 allow calculation of the thermal separation time based on provisions of FDS 3.6. Specific provisions for calculation of thermal separation time allow more accurate fire protection times to be assigned to wood cover and Type X gypsum panel membranes for the calculation of structural fire resistance times without overpredicting the thermal separation times provided by these membranes. Note that, where the calculated thermal separation time for a structural assembly exceeds the structural fire resistance time, the thermal separation time must be limited to the structural fire resistance time, because the structural members are required to hold the membranes and insulation (if present) in place.

C3.9.2.1 Contribution from Membranes: Thermal separation times assigned to protective membranes are based on the protection times in FDS Tables 3.9.1.2a and 3.9.1.2b. Where a single layer of wood or Type X gypsum panel membrane is used to provide all of the thermal separation or where the final layer of thermal separation on the unexposed side of the assembly is a wood layer or Type X gypsum panel layer, the time assigned to that wood layer or Type X gypsum panel layer is multiplied by 0.85 based on FDS 3.6.1.1 or 0.5 based on FDS 3.6.2.1, respectively.

C3.9.2.2 Contribution from Insulation: Thermal separation times assigned to insulation in FDS Table 3.9.2.2 assume that the insulation fills the cavity between the studs in a wall or is continuous between joists or trusses in a horizontal assembly. Because thicknesses of mineral wool insulation and fiberglass insulation greater than 3.5 inches did not provide increased protection times, the tabulated protection times specified in FDS Table 3.4.3.1 are not to be additive with each other and should not be increased for additional insulation thickness, density, or R-value without additional testing (see also C3.4.3).

C3.10 Design of Protected Connections

Wood structural connections in a fire-resistance-rated member or assembly must perform their function for the time corresponding to the required fire resistance rating. For wood-frame assemblies, such as wall, floor, and roof assemblies, testing and calculations have demonstrated that structural connections within a fire-resistance rated assembly are adequately protected to ensure that the assembly meets the required fire resistance rating. For wood members that are not within an assembly, such as beams and columns, structural connections to or between these wood members are typically protected using the same or additional protection used to protect the wood members. Since neither ASTM E119 nor UL 263 contain provisions for testing the fire resistance of structural connections, these connections are designed using the requirements of FDS 3.10. For wood structural connections, all required components of the connection are required to be protected, including any metal connectors, fasteners that are part of the structural connection, and portions of the connected members that are part of the structural connection. Fasteners that attach the protection, but are not part of the structural connection, do not need to be protected; however, those fasteners should meet the minimum attachment requirements in FDS 3.4.1.4 for wood cover and in FDS 3.4.2.3 for Type X gypsum panel product protection.

Examples of connection protection design are provided in Part V of TR10. Specifically, these design examples address protection of a steel ledger connection, protection of a beam-column connection using a hidden bearing connector, and protection of a tension splice connector. The

principles and procedures demonstrated in these design examples can be applied to connection protection design for a wide range of connections that are commonly used in wood construction.

C3.10.1 Connection Protection

Because there are no established procedures to design exposed structural connections, including wood-to-metal connections and wood-to-wood connections using metal hardware for a fire-resistance rating, these connections must be protected for the full structural fire-resistance time required of the connected members. Using the provisions of FDS 3.6 ensures that no part of the connection is exposed to an average temperature rise of 250°F or an individual temperature rise of 325°F, well below the level of significant strength loss of steel or charring of wood. Intumescent paints and coatings often used on metal parts and connections do not typically work for wood-to-metal connections since intumescent paints and coatings need to expand to protect the connection and there is often not sufficient space for this to occur. If space is provided to allow for expansion of the intumescent paints or coatings, they can dislodge as the wood chars or the reduction in cross-section due to charring can expose unpainted or uncoated metal parts. If intumescent paints or coatings are to be used on wood-to-metal connections or wood-to-wood connections using metal hardware, the intumescent paints or coatings should be tested for the proposed use and demonstrate adequate fire resistance in that specific application.

C3.10.2 Intersections and Abutting Edges of Exposed Wood Members and Wood Cover

Char penetration at unbonded wood member ends and edges can adversely impact the protection provided by portions of the wood member that are not part of the structural connection or additional wood cover that is intended to protect the structural connection. Detailing that considers the effects of char penetration should be incorporated in the connection protection design. See C3.2.3. Examples of protection detailing structural connections at ends and edges of wood members are provided in TR10 [17].

COMMENTARY REFERENCES

1. ANSI/AWC NDS-2024: “National Design Specification® (NDS®) for Wood Construction”. American Wood Council, Leesburg, VA, 2023.
2. International Building Code (IBC). International Code Council, Washington, DC, 2021.
3. NFPA 268-2017: “Standard Test Method for Determining Ignitability of Exterior Wall Assemblies Using a Radiant Heat Energy Source, 2017 Edition”. National Fire Protection Association [NFPA], New York, NY, 2017.
4. ASTM E84 - 20: “Standard Test Method for Surface Burning Characteristics of Building Materials”. ASTM, Philadelphia, PA, 2020.
5. UL 723: “Standard for Test for Surface Burning Characteristics of Building Materials”. Underwriters Laboratories Inc, Northbrook, IL, 2018.
6. NFPA 286-2019: “Standard Methods of Fire Tests for Evaluating Contribution of Wall and Ceiling Interior Finish to Room Fire Growth”. National Fire Protection Association [NFPA], New York, NY, 2019.
7. ASTM E648 – 19ae1: “Standard Test Method for Critical Radiant Flux of Floor-Covering Systems Using a Radiant Heat Energy Source”. ASTM, Philadelphia, PA, 2019.
8. NFPA 253-2019: “Standard Method of Test for Critical Radiant Flux of Floor Covering Systems Using a Radiant Heat Energy Source”. National Fire Protection Association [NFPA], New York, NY, 2019.
9. NFPA 13-2019: “Standard for the Installation of Sprinkler Systems”. National Fire Protection Association [NFPA], New York, NY, 2019.
10. NFPA 13R-2019: “Standard for the Installation of Sprinkler Systems in Low-Rise Residential Occupancies”. National Fire Protection Association [NFPA], New York, NY, 2019.
11. ASTM D2859 – 16: “Standard Test Method for Ignition Characteristics of Finished Textile Floor Covering Materials”. ASTM, Philadelphia, PA, 2016.
12. ASTM E2768 – 11(2018): “Standard Test Method for Extended Duration Surface Burning Characteristics of Building Materials (30 min Tunnel Test)”. ASTM, Philadelphia, PA, 2018.
13. ASTM E119 - 20: “Standard Test Methods for Fire Tests of Building Construction and Materials”. ASTM, Philadelphia, PA, 2020.
14. UL 263. “Fire Tests of Building Construction and Material”. Underwriters Laboratories Inc, Northbrook, IL, 2014.
15. ASTM D6513 – 14: “Standard Practice for Calculating the Superimposed Load on Wood-frame Walls for Standard Fire-Resistance Tests”. ASTM, Philadelphia, PA, 2014.
16. ASTM D7746 – 11(2016): “Standard Practice for Calculating the Superimposed Load on Wood-frame Floor-Ceiling Assemblies for Standard Fire-Resistance Tests”. ASTM, Philadelphia, PA, 2016.

17. TR10-2020: “Technical Report 10: Calculating the Fire Resistance of Wood Members and Assemblies”. American Wood Council, Leesburg, VA, 2020.
18. White, Robert H., “Charring Rates of Different Wood Species,” PhD Thesis, University of Wisconsin, Madison, WI, 1988.
19. ANSI/APA PRG 320-19: “Standard for Performance-Rated Cross-Laminated Timber”, APA – The Engineered Wood Association, 7011 South 19th Street, Tacoma, WA. 2019.
20. ASTM D245 – 06(2019): “Standard Practice for Establishing Structural Grades and Related Allowable Properties for Visually Graded Lumber”. ASTM, Philadelphia, PA, 2019.
21. ASTM D3737 – 18e1: “Standard Practice for Establishing Allowable Properties for Structural Glued Laminated Timber (Glulam)”. ASTM, Philadelphia, PA, 2018.
22. ASTM D5456 – 19: “Standard Specification for Evaluation of Structural Composite Lumber Products”. ASTM, Philadelphia, PA, 2019.
23. Wood Handbook, Agriculture Handbook No. 72, U.S. Department of Agriculture, Forest Service, Forest Products Laboratory, Washington, DC, 2010.
24. NDS Supplement to the National Design Specification® (NDS®) for Wood Construction. American Wood Council, Leesburg, VA, 2023.
25. White, Robert H. “Fire Resistance of Engineered Wood Rim Board Products”, Research Paper FPL-RP-610, U.S. Forest Products Laboratory, U.S. Department of Agriculture, Madison, WI, May 2003.
26. “Fire Resistance Testing of CLT Floor/Ceiling Assemblies to Establish Contribution of Gypsum Protection”. WFCi Report #17091r1, Western Fire Center Inc., Kelso, WA, November 28, 2017.
27. Bénichou, N.; Sultan, M.A.; MacCallum, C.; and Hum, J. “Thermal Properties of Wood, Gypsum and Insulation at Elevated Temperatures”. IR-710. National Research Council of Canada. ON, Canada, October 2001.
28. ISO 834:2019 “Fire-Resistance Tests - Elements of Building Construction”. International Organization for Standardization, Geneva, Switzerland, 2019.
29. CAN/ULC S101, “Standard Methods of Fire Endurance Tests of Building Construction and Materials”, Underwriters’ Laboratories of Canada, Toronto, ON, Canada, 2014.
30. ASTM D5457 - 20: “Standard Specification for Computing Reference Resistance of Wood-Based Materials and Structural Connections for Load and Resistance Factor Design”. ASTM, Philadelphia, PA, 2020.
31. “Fire Resistance Testing of Beam/Column Intersections”, WFCi Report #20062, Western Fire Center Inc., Kelso, WA, November 19, 2020.
32. Gerhards, C.C; “Effect of Moisture Content and Temperature on the Mechanical Properties of Wood: An Analysis of Immediate Effects”. Wood and Fiber, 14(1), 1982, pp 4-36.
33. GA-223-2024, “Gypsum Panel Products Types, Uses, and Standards”. Gypsum Association, Silver Spring, MD, 2024.

50 Catoctin Circle NE, Suite 201
Leesburg, VA 20176
202 463 2766 | info@awc.org
awc.org

