

Calculating the Fire Resistance of Wood Members and Assemblies

Technical Report No. 10



AMERICAN
WOOD
COUNCIL

The procedure described in this technical report are intended to assist the designer of timber framed structures in achieving predictable performance against specified fire endurance requirements. Special effort has been made to assure that the information reflects the state of the art. However, the American Wood Council does not assume any responsibility for particular designs or calculations prepared from this publication.

For additional information or assistance contact:

American Wood Council
Suite 201, 222 Catocin Circle
Leesburg, VA 20175

TABLE OF CONTENTS FOR TR10

Part/Title	Page
1 Development of Design Procedures for Exposed Wood Members	5
1.1 Introduction	5
1.2 Concepts of Fire Design of Wood	5
1.3 Background	6
1.4 Mechanics-Based Design Method for Unprotected Wood Members	9
1.5 Wood as a Protective Element	12
2 Comparison of Calculation Methods and Experiments	15
2.1 General	15
2.2 Beams	15
2.3 Columns	17
2.4 Tension Members	23
2.5 Decking	25
2.6 Unprotected Floor Joists	27
2.7 Structural Composite Lumber	33
2.8 Cross-Laminated Timber	37
2.9 Summary	41
3 Protection of Structural Members and Connections	42
3.1 General	42
3.2 Background	42
3.3 AWC Stud Wall Tests	45
3.4 Light-Weight Floor-Ceiling Tests	52
3.5 Rim Board Tests	58
3.6 AWC GWB-Protected Beam Tests	65
3.7 Cross-Laminated Timber Protected Wall and Floor Tests	66
3.8 Summary	72
4 Design Procedures for Exposed and Protected Wood Members	76
4.1 Design Procedures for Exposed Wood Members	76
4.2 Design Procedures for Timber Decks	79
4.3 Special Provisions for Glued Laminated Timber Beams	80

4.4 Protection of Wood Structural Members and Connections	81
4.5 Wood Connections	84
5 Application Guidelines and Design Examples	89
5.1 Application Guidelines for Wood Members	89
Example 1: Exposed Beam	90
Example 2: Exposed Column	92
Example 3: Exposed Tension Member	94
Example 4: Exposed Decking	96
Example 5: Exposed CLT Floor	99
Example 6: Exposed CLT Wall	101
Example 7: Protected 2x10 Joist Floor Assembly	105
Example 8: Protection of Steel Ledger Connection	108
Example 9: Protection of Beam-Column Connection	112
Example 10: Protection of Tension Splice Connection	116
 References	 121
 APPENDIX A: Derivation of Load Ratio Tables	 125
 APPENDIX B: Fire Resistance Calculation for Sawn Wood Joists	 136
 APPENDIX C: Harmathy's Ten Rules of Fire Endurance (Resistance) Rating	 137

Part I: Development of Design Procedures for Exposed Wood Members

1.1 Introduction

Wood members have long been recognized for their ability to maintain structural integrity when exposed to fire. Early mill construction from the 19th century utilized timbers to carry large loads and to resist structural failure from fire. Exposed wood structural members are popular with architects and designers of modern buildings because they have a pleasing appearance and are economical and easy to use, while providing necessary fire resistance. Glued laminated (glulam) and Structural Composite Lumber (SCL) members are now commonly used where large sections and long spans are needed. Glulam and SCL members are composed of smaller pieces of wood that are glued together. Glulam and SCL members offer the same fire performance advantages as sawn members of a similar size. Extensive research has demonstrated that adhesives used in the manufacture of glulam and SCL do not adversely affect fire performance [1].

The superior fire performance of timber can be attributed to the charring effect of wood. As wood members are exposed to fire, an insulating char layer is formed that protects the core of the section. Thus, beams and columns can be designed so that a sufficient cross section of wood remains to sustain the design loads for the required duration of fire exposure. In North America, a standard fire exposure is used for design purposes and is described in the relevant standard fire resistance test ASTM E 119 [2]. Many other countries use comparable test exposures found in ISO 834 [3] and CAN/ULC S101 [49]. In spite of the differences between standard fire resistance tests, experimental charring rates measured in various parts of the world appear to be consistent. This justifies the use of such data for design, regardless of origin.

1.2 Concepts of Fire Design of Wood

At fire exposure time t , the initial breadth, B , and depth, D , of a member are reduced to b and d , respectively. This is illustrated in Figure 1-1 for a section of a beam exposed on three side where the original section is rectangular. However, since the corners are subject to heat transfer from two directions, charring is faster at these corners. This has a rounding effect, and shortly after ignition the remaining cross section is no longer rectangular. The boundary between the char layer and the remaining wood section is quite distinct, and corresponds to a temperature of approximately 550°F. The remaining wood section is heated over a narrow region that increases to approximately 1.6" from the char front after about 20 minutes [13]. The inner core of the remaining wood section is at ambient (or initial) temperature. A section smaller than the original section is capable of supporting the design load because of the margin of safety provided in cold design. The original section is stressed only to a fraction of the maximum

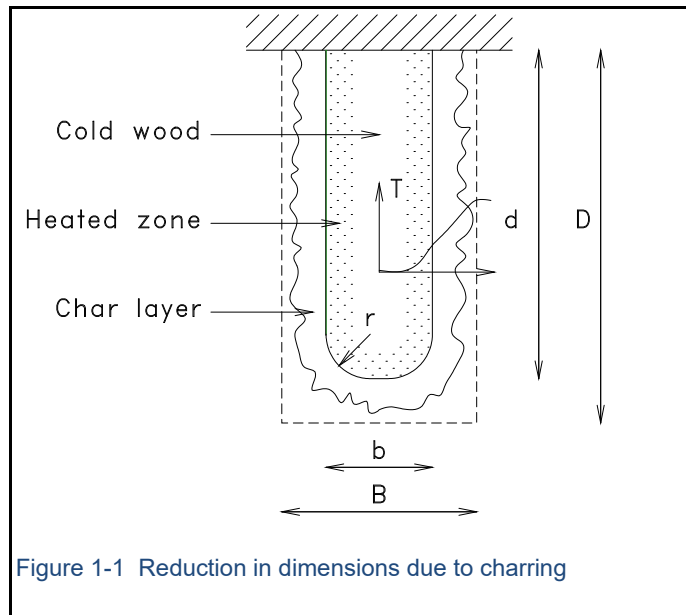

capacity. Failure occurs when the remaining cross section is stressed beyond the maximum capacity.

For members stressed in bending during fire exposure, failure occurs when the maximum bending capacity is exceeded due to the reduction in section modulus, S . For members stressed in tension parallel-to-grain during fire exposure, failure occurs when the maximum tension capacity is exceeded due to the reduction in cross-sectional area, A .

For members stressed in compression parallel-to-grain during fire exposure, the failure mode is a function of the column slenderness ratio, (L_e/D) . The column slenderness ratio changes with exposure time. For short column members ($L_e/D \approx 0$) stressed in compression during fire exposure, failure occurs when maximum compressive capacity is exceeded due to the reduction in cross-sectional area, A . For long column members ($L_e/D \approx \infty$) stressed in compression during fire exposure, failure occurs when critical buckling capacity is exceeded due to the reduction in the moment of inertia, I . Current code-accepted design procedures in the *National Design Specification® for Wood Construction (NDS®)* contain a single column equation that is used to calculate a stability factor, C_p , which approximates the column capacity for all slenderness ratios based on the calculated interaction of theoretical short and long column capacities [9].

1.3 Background

For over 20 years, the only building code-accepted design method for fire-resistive exposed wood members used in North America was based on analysis conducted by T.T. Lie at the National Research Council of Canada (NRC) in the 1970's [4]. The method was first recognized by the U.S. model building codes in 1984 through a National Evaluation Report [5]. In subsequent years, the method was adopted by the three model code organizations that existed at that time, allowing engineers and architects to include fire resistance-rated timber members in their projects without conducting expensive standard fire resistance tests.

In his research, Lie assumed a linear char rate of 1.42 in/hr and accounted for a reduction in strength and stiffness due to heating of a small zone progressing ahead of the char front. Lie reported that studies had shown that the ultimate strength and stiffness of uncharred wood of various wood species reduced to about 0.85-0.90 of the original strength and stiffness. To account for this effect, reductions to strength and stiffness properties were implemented by uniformly reducing strength and stiffness values over the remaining cross section by a factor α . Furthermore, a factor k was introduced to account for the ratio of design strength to ultimate strength. To obtain conservative estimates, Lie recommended a k factor of 0.33 based on a safety factor of 3, and an α factor of 0.8 to account for a strength and stiffness reduction.

However, Lie ignored increased rate of charring at the corners, and assumed that the remaining section was rectangular. With this assumption, initial breadth B and depth D of a member after t minutes of fire exposure are reduced to b and d respectively, as shown in Figure 1-2. As noted above, both b and d are a function of exposure time, t , and charring rate, β .

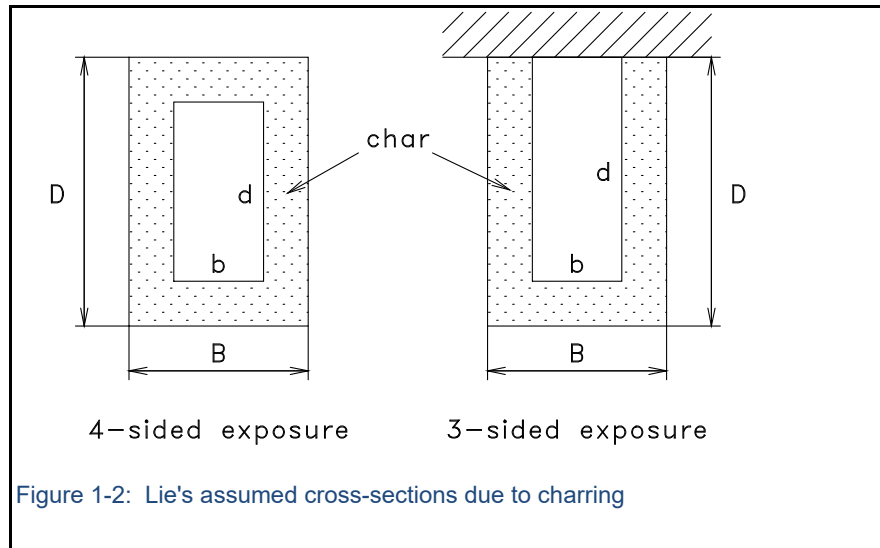

Figure 1-2: Lie's assumed cross-sections due to charring

Assuming the charring rate is identical in every direction, the exposure time t and the dimensions of the initial and remaining cross section are related via the charring rate, β :

$$t = \begin{cases} \frac{B-b}{2\beta} = \frac{D-d}{2\beta} & 4\text{-sided exposure} \\ \frac{B-b}{2\beta} = \frac{D-d}{\beta} & 3\text{-sided exposure} \end{cases} \quad \text{(Equation 1.3-1)}$$

1.3.1 Beams

Lie's method assumed that a beam fails when the reduction in cross section results in a critical value of the section modulus, S . Assuming a safety factor reduction of k , a load factor of Z , and a uniform reduction in strength properties of α , the critical section is determined from:

$$k Z \frac{BD^2}{6} = \alpha \frac{bd^2}{6} \quad \text{(Equation 1.3-2)}$$

Given the initial dimensions B (width) and D (depth), the fire resistance time can be calculated by combining equations (1.3-1) and (1.3-2), and solving the resulting equation for t . The roots to the resulting equations must be solved iteratively. To avoid these cumbersome iterative procedures, Lie approximated his solutions with a set of simple equations that allow for a straightforward calculation of fire resistance time as a function of member size for a realistic range of member dimensions. Lie approximated the solutions for $\alpha=0.8$ and $k=0.33$ to:

$$t_f = \begin{cases} 2.54 Z B \left(4 - \frac{2B}{D} \right) & 4\text{-sided exposure} \\ 2.54 Z B \left(4 - \frac{B}{D} \right) & 3\text{-sided exposure} \end{cases} \quad \text{(Equation 1.3-3)}$$

with

$$Z = \begin{cases} 1.3 & R < 0.5 \\ 0.7 + \frac{0.3}{R} & R \geq 0.5 \end{cases} \quad (\text{Equation 1.3-4})$$

where R is the ratio of applied to allowable load, t_f is in minutes, and all dimensions are in inches.

1.3.2 Columns

As noted in the previous section, column failure mode depends on the slenderness ratio. Short columns fail when the reduction in cross section results in a critical value for the cross-sectional area A being reached. Assuming a safety factor reduction of k , a load factor of Z , and a uniform reduction in strength properties of α , the critical section is determined from:

$$k Z B D = \alpha b d \quad (\text{Equation 1.3-5})$$

Long columns fail when the reduction in cross section results in a critical value for the moment of inertia, I . Assuming a safety factor reduction of k , a load factor of Z , and a uniform reduction in strength properties of α , the critical section is determined from:

$$k Z \frac{B D^3}{12} = \alpha \frac{b d^3}{12} \quad (\text{Equation 1.3-6})$$

where D denotes the narrowest dimension of a column section and buckling is assumed to occur in the weakest direction.

Again, given the initial dimensions B (widest dimension) and D (narrowest dimension), the fire resistance time can be calculated for short columns by combining equations (1.3-1) and (1.3-5) or for long columns by combining equations (1.3-1) and (1.3-6). Again, to avoid the cumbersome iterative solution of these equations, Lie approximated his solutions with a set of simple equations using equation (1.3-2) as an average between equation (1.3-5) for short columns and equation (1.3-6) for long columns. Therefore, Lie approximated the solutions for $\alpha=0.8$ and $k=0.33$ to:

$$t_f = \begin{cases} 2.54 Z D \left(3 - \frac{D}{B} \right) & 4\text{-sided exposure} \\ 2.54 Z D \left(3 - \frac{D}{2B} \right) & 3\text{-sided exposure} \end{cases} \quad (\text{Equation 1.3-7})$$

where Z for short columns ($K_e l / D \leq 11$) follows from

$$Z = \begin{cases} 1.5 & R < 0.5 \\ 0.9 + \frac{0.3}{R} & R \geq 0.5 \end{cases} \quad (\text{Equation 1.3-8})$$

where Z for long columns ($K_e l / D > 11$) follows from

$$Z = \begin{cases} 1.3 & R < 0.5 \\ 0.7 + \frac{0.3}{R} & R \geq 0.5 \end{cases} \quad (\text{Equation 1.3-9})$$

where R is the ratio of applied to allowable load, t_f is in minutes, and all dimensions are in inches.

To determine the fire resistance of columns, Lie used the geometric mean of the equations for the extreme cases of short and long columns. Lie assumed that short columns fail due to crushing, and long columns fail due to buckling. To correct for underprediction of failure times for short columns, Lie recommended an increase to the load factor for such columns. In 1991, the NDS provisions for columns were changed from three equations for different ranges of slenderness to a single equation [9]. As a result, Lie's methodology for columns is not consistent with the current procedure for structural design of wood members.

Notably, Lie verified his method against experimental data from full-size column tests conducted in France [6], England [7], and Germany [8] in the 1960's and early 1970's. In his original paper [4], Lie noted that no beam data were available for comparison. Lie assumed that his calculation method would be valid for beams also, since it was based on the same assumptions and concepts as that for columns. Since Lie's initial work, standard fire test data have now been published for at least 7 heavy timber beams [16][17][18][23].

1.4 Mechanics-Based Design Method for Unprotected Wood Members

Lie's design method for exposed wood members was based on actual fire test results and sound engineering; however, since the final equations were based on empirical solutions fit to limited beam and column test data, assumed loading and bracing conditions, and typical exposures, the application was limited. In 1999, a new mechanics-based design method was developed to permit the calculation of fire resistance for exposed wood members for other loading conditions and fire exposures not considered by Lie [63].

The mechanics-based design method calculates the capacity of fire-resistive exposed wood members using the mechanics assumed by Lie. Failure of a member occurs when the load on the member exceeds the member capacity that has been reduced due to fire exposure. However, actual mechanical and physical properties are used, and the capacity of the member is directly calculated for a given period. For structural calculations, section properties are computed based on an effective char depth, a_{eff} , calculated assuming a non-linear char rate, β_t , at a given time, t . Average member strength properties are approximated from test data or from procedures used to calculate design properties.

1.4.1 Char Rate

To estimate the reduced cross-sectional dimensions, b and d, the location of the char front must be determined as a function of time on the basis of empirical charring data. The char layer can be assumed to have zero strength and stiffness. For structural calculations, the physical shape of the remaining section and its load carrying capacity should be adjusted to account for loss of strength and stiffness in the heated zone and rounding at corners. In design there are various documented approaches to account for these effects:

- additional reduction of the remaining section [10][11];
- uniform reduction of the maximum strength and stiffness [4][10][12]; or
- more detailed analysis with subdivision of the remaining section into several zones at different temperatures [13][14].

Extensive one-dimensional char rate data is available for wood slabs. Data is also available for two-dimensional charring of timbers, but most of this data is limited to larger cross-sections. Evaluation of one-dimensional char rate data suggests that charring of wood is nonlinear and estimates using linear models tend to underestimate char depth, a_{char} , for short time periods (<60 minutes) and overestimate a_{char} for longer time periods (>60 minutes). One method for correcting for nonlinear char is the use of empirical adjustments, such as the addition of an artificial char time, t_c :

$$a_{char} = \beta (t + t_c) \quad (\text{Equation 1.4-1})$$

However, these types of corrections are awkward to handle in fire resistance models and tend to over-compensate when adjusting for shorter time periods.

To account for char rate nonlinearity, White developed a nonlinear, one-dimensional char rate model based on the results of 40 one-dimensional charring tests of wood slabs of various wood species [24]. White's non-linear model addressed accelerated charring which occurs early in the fire exposure by applying a power factor to the char depth, a_{char} , to adjust for char rate nonlinearity:

$$t = m a_{char}^{1.23} \quad (\text{Equation 1.4-2})$$

However, application of White's model is limited since the char constant ($\text{min/in}^{1.23}$), m , is species-specific and only limited data exists for different wood species fit to White's model. In addition, the model is limited to one-dimensional charring data of wood slabs.

To develop a two-dimensional, nonlinear char rate model, White's non-linear char rate model was modified to enable values for the char constant m to be estimated using nominal char rate values (in/hr), β_n , using measured char depth at approximately one hour. From this relationship, a_{char} can be expressed as follows:

$$a_{char} = \beta_n t \quad (\text{Equation 1.4-3})$$

Solving for a_{char} in White's equations provides:

$$a_{char} = \left(\frac{t}{m}\right)^{0.813} \quad (\text{Equation 1.4-4})$$

At $t = 1 \text{ hr}$, the two equations for a_{char} are equal. Setting the equations equal at 1 hour and solving for the non-linear char constant, m :

$$\beta_n (1 \text{ hr}) = \left(\frac{1 \text{ hr}}{m}\right)^{0.813} \quad (\text{Equation 1.4-5})$$

$$m = \frac{(1 \text{ hr})}{(\beta_n (1 \text{ hr}))^{1.23}} \quad (\text{Equation 1.4-6})$$

Substituting the value of m back into the non-linear equation for a_{char} provides an equation for calculating the char depth, a_{char} , in terms of the reference nominal char rate, β_n , and the exposure time, t :

$$a_{char} = \frac{\beta_n (1 \text{ hr}) t^{0.813}}{(1 \text{ hr})^{0.813}} = \frac{\beta_n (1 \text{ hr})}{(1 \text{ hr})^{0.813}} t^{0.813} \quad (\text{Equation 1.4-7})$$

To ensure that units are used consistently, a new term is created. This new term called the non-linear char rate constant, β_t , is defined as:

$$\beta_t = \beta_n \frac{(1 \text{ hr})}{(1 \text{ hr})^{0.813}} \quad (\text{Equation 1.4-8})$$

The char depth, a_{char} , can now be expressed in terms of the non-linear char rate constant, β_t :

$$a_{char} = \beta_t t^{0.813} \quad (\text{Equation 1.4-9})$$

Where,

- β_t = Non-linear char rate constant, inches/hr^{0.813}
- β_n = Reference nominal char rate, inches/hr
- t = exposure time, hr
- a_{char} = char depth, inches

For structural calculations, the effective char depth, a_{eff} , is estimated to be 20% deeper than a_{char} to account for reduction of strength and stiffness of the heated zone and rounding at the corners as shown in the following equation (1.4-10):

$$a_{eff} = 1.2 a_{char} \quad (\text{Equation 1.4-10})$$

For structural calculations, the section properties are calculated using standard equations for area, section modulus and moment of inertia using reduced cross-sectional dimensions. The dimensions are reduced by a_{eff} for each surface exposed to fire. Cross-sectional properties for a member exposed on all four sides are:

Table 1.4.1 Cross-Sectional Properties for Four-Sided Exposure

Cross-sectional Property	Four-Sided Exposure Example
Area of the cross-section, in ²	$A(t) = (D_{min} - 2a_{eff})(D_{max} - 2a_{eff})$
Section Modulus about major-axis, in ³	$S_{major}(t) = (D_{min} - 2a_{eff})(D_{max} - 2a_{eff})^2/6$
Section Modulus about minor-axis, in ³	$S_{minor}(t) = (D_{min} - 2a_{eff})^2(D_{max} - 2a_{eff})/6$
Moment of Inertia about major-axis, in ⁴	$I_{major}(t) = (D_{min} - 2a_{eff})(D_{max} - 2a_{eff})^3/12$
Moment of Inertia about minor-axis, in ⁴	$I_{minor}(t) = (D_{min} - 2a_{eff})^3(D_{max} - 2a_{eff})/12$

Other exposures can be calculated using this method.

Sides of individual timber decking members are shielded from full fire exposure by adjacent members collectively acting as a joint. Partial exposure can occur as members contract and gaps between members open. The degree of exposure is a function of 1) the angle of incidence between the surface under consideration and the radiant heat flux, and 2) the ability of hot volatile gases to pass through the joints. When the joint is completely open, such as can occur with butt-jointed timber decking, hot gases will carry into the joint and the sides of the decking members will char. This charring can be conservatively approximated assuming the sides of a member along the joint char at the effective char rate. When the joint is open but covered by sheathing, as with butt-jointed timber decking covered with wood structural panels, passage of hot gases is limited,

and tests have shown that charring can be approximated assuming a partial exposure char rate along the joint equal to one-third of the effective char rate [22]. For joints which are not open, as with tongue-and-groove timber decking, tests have shown that charring of the sides of members is negligible and can be ignored [21][22].

1.4.2 Approximation of Average Ultimate Strength

Average ultimate strength for unheated members can be approximated using published allowable stress design (ASD) values at NDS reference conditions (ASD reference values). To estimate a lower bound of the average ultimate strength, the ASD reference value can be multiplied by the adjustment factor, K , to adjust from an ASD reference value, which is based on a 5% exclusion value and “normal” (10-year) load duration, to an average ultimate strength based on short-term tests. The adjustment factor, K , has two components, the inverse of the applicable design value adjustment factor (from ASTM D245 [15a] for lumber, ASTM D3737 [15b] for glulam, ASTM D5456 [15c] for structural composite lumber), denoted as $1/k$, and the inverse of the variability adjustment factor, denoted as c . To develop general design procedures for wood members, the adjustment factors and estimates of COV listed in Table 1.4.2 were used. The assumed COV values are estimates from clear wood properties.

Table 1.4.2 ASD Reference Value to Average Ultimate Strength Adjustment Factors

	F	$1/k$	c	Assumed COV	K
Bending Strength	F_b	2.1 ¹	1-1.645 COV _b	0.16 ²	2.85
Tensile Strength	F_t	2.1 ¹	1-1.645 COV _t	0.16 ²	2.85
Shear Strength	F_v	2.1 ¹	1-1.645 COV _v	0.14 ²	2.75
Compression Strength	F_c	1.9 ¹	1-1.645 COV _c	0.16 ²	2.58
Buckling Strength	E_{05}	1.66 ⁴	1-1.645 COV _E	0.11 ⁵	2.03

¹ taken from Table 10 of ASTM D245 *Standard Practice for Establishing Structural Grades and Related Allowable Properties for Visually Graded Lumber*, Table 1 of ASTM D3737 *Standard Practice for Establishing Allowable Properties for Structural Glued Laminated Timber (Glulam)*, and Table 1 of ASTM D5456 *Standard Specification for Evaluation of Structural Composite Lumber Products*.

² taken from Table 5-6 of 2010 *Wood Handbook for clear wood bending values*.

³ taken from Table 5-6 of 2010 *Wood Handbook for clear wood shear values*.

⁴ taken from Appendices D and H of 2018 *National Design Specification for Wood Construction*.

⁵ taken from Appendix F of 2018 *National Design Specification for Wood Construction*.

1.4.3 Approximation of Member Capacity

As noted, average ultimate capacity of a wood member exposed to fire for a given time, t , can be estimated using cross-sectional properties reduced for fire exposure time and average ultimate strengths derived from ASD reference values.

1.5 Wood as a Protective Element

An estimation of char depth a_{char} , is also necessary for predicting the amount of protection provided by wood used as a protective element. While both the char layer and the remaining wood behind the char layer serve as a thermal barrier, the ability to estimate the char depth, a_{char} , as a function of fire exposure time allows calculation of the thermal protection provided to the member covered by the protective element.

1.5.1 Char Contraction

As wood chars, it contracts so that the thickness of the char layer is less than the depth of the wood that has charred, previously denoted as a_{char} (see Figure 1-3). For structural calculations, the uncharred wood remaining after a given exposure time is all that is needed; however, where wood is used as a thermal-protective element and the char layer serves as an insulating layer, char contraction must be considered at ends and edges of protective elements. White measured the char contraction on the same wood specimens that were used to develop the non-linear char model [24]. Measured ratios of char thickness to a_{char} ranged from 0.50 to 0.90, with an average value of approximately 0.70 and a COV of 0.17.

To account for contraction of the char layer, the loss of section is defined by a Char Contraction Factor, C_{CF} , and estimated using the average ratio observed by White with the following equation:

$$\text{Char Contraction Factor, } C_{CF} = 1 - \frac{\text{char thickness}}{a_{char}} = 1 - 0.7 = 0.3 \quad (\text{Equation 1.5-1})$$

The loss of dimension at any location within the char layer can thus be estimated by multiplying the char depth, a_{char} , at that location by $C_{CF} = 0.3$ as shown in Figure 1-3. For example, a wood member with $a_{char} = 1$ inch in the face of the member would have a char contraction of approximately 0.3 inches, leaving a char thickness of 0.7 inches.

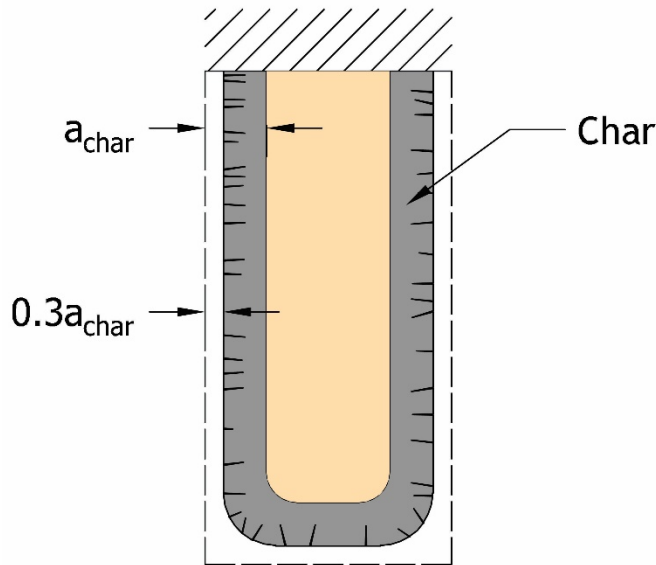

Figure 1-3. Char contraction

1.5.2 Char Contraction at Ends and Edges of Wood Members

Charring and char contraction begin soon after ignition of the wood. Char contraction at unbonded wood member ends and edges results in ignition, albeit delayed, of wood surfaces in the gaps at these locations, as shown in Figure 1-4. As a result, ignition extends into these gaps a distance that is approximately twice the char depth, $2a_{char}$, as shown in Figure 1-5. Ignition occurs when the wood is initially exposed to fire providing insufficient time for an elevated temperature zone to form at the point of ignition. Since the elevated temperature zone does not initially extend beyond the point of ignition in the gap created by char contraction, the char penetration into the gap does not need to be increased by the 1.2 factor used for structural

calculations. The elevated temperature zone is depicted by the red line in Figure 1-5.



Figure 1-4. Example of char contraction at abutting edges of CLT floor panels (photo courtesy of Katerra).

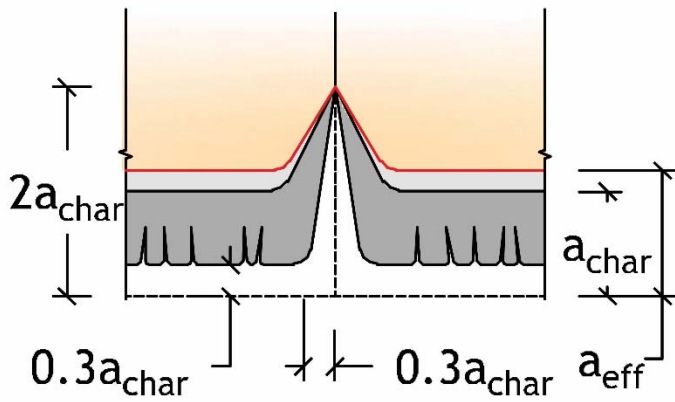

Figure 1-5. Char contraction at abutting wood members that are unbonded

Part II: Comparison of Calculation Methods and Experiments

2.1 General

Test results from fire tests of exposed wood members were compared against the mechanics-based model predictions. International, as well as North American, test data were reviewed. The results indicate that the mechanics-based method accurately estimates the fire resistance time of tested wood members and overall, is more accurate than the T. T. Lie method with its limitations discussed in Part I.

2.2 Beams

The Timber Research and Development Association (TRADA) in Great Britain conducted a series of tests on glulam beams in 1968 [16]. Only one of the tests was continued until structural failure, which occurred after 53 minutes of exposure to standard BS 476 fire conditions (similar to ISO 834 and ASTM E119). The test configuration consisted of four nominal 5.5-inch x 9-inch glulam whitewood beams. The report contained information which permitted the estimation of allowable stresses for use with the NDS: $F_b=2000$ psi and $E=1.4E6$ psi [13]. The beams were braced against lateral translation and rotation at the supports and were braced against lateral translation and loaded through 11 evenly spaced 2x4 bearing members; therefore, an effective length, $l_e=1.84 l_u$ (l_u = full span/11), was assumed. Using NDS behavioral equations, the allowable resisting moment was estimated to be 12,200 ft-lb compared to an induced moment of 9,820 ft-lb. The ratio of induced load to ASD design load based on the NDS was 80% for this test.

The National Forest Products Association (NFoPA) (now the American Wood Council), sponsored a test on a Douglas fir glulam beam in 1986 [17]. The beam collapsed after 86 minutes of standard ASTM E 119 fire exposure. The reported allowable stresses were $F_b=2400$ psi and $E=1.6E6$ psi. The beam was braced against lateral translation and rotation at the supports and was loaded through 3 evenly spaced hydraulic cylinders. While the center cylinder was braced to maintain a vertical orientation, the beam was only braced at the ends; therefore, an effective length, $l_e=1.84 l_u$ (l_u = full span), was assumed. Using the NDS behavioral equations, the allowable resisting moment was estimated to be 73,900 ft-lb compared to an induced moment of 55,900 ft-lb. The reported ratio of induced load to ASD design load based on the 1986 NDS was 72% [13], but due to changes in the NDS design provisions since 1986, the ASD design ratio is 76%.

Dayeh and Syme reported results for Brush box and Radiata pine glulam beams tested by the Forestry Commission of New South Wales (FCNSW) according to AS 1720 Part 1 [18][26]. The report contained information which permitted the estimation of allowable stresses for use with the NDS provisions: for the Brush box glulam beam, $F_b=2500$ psi and $E=2.2E6$ psi, and for the Radiata pine glulam beam, $F_b=1800$ psi and $E=1.8E6$ psi. The beams were braced against lateral translation and rotation at the supports and were loaded at 2 evenly spaced load points. The beams appeared to have been braced at the load points; therefore, an effective length, $l_e=1.68 l_u$ (l_u = full span/3), was assumed. Using NDS behavioral equations, the allowable resisting moment for the Brush box beam was estimated to be 53,900 ft-lb compared to an induced moment of 74,800 ft-lb and the allowable resisting moment for the Radiata pine beam was estimated to be 38,800 ft-lb compared to an induced moment of 20,500 ft-lb. The ratios of induced load to ASD design load were 139% and 53% and failure times were 59 minutes and 67 minutes, respectively.

In 1997, the predecessor organization of the American Wood Council conducted a series of four experimental beam tests at Southwest Research Institute (SwRI) [23]. The primary

objectives of the tests were to evaluate the effect of load on the fire resistance of glulam beams, and to determine whether the load factor equation in Lie’s calculation method is valid for allowable load ratios lower than 50%. The same type of beam was used as in the 1986 test conducted by NFoPA, so that results from that test would provide an additional data point for the load ratio curve. The first of the four tests was conducted without external load, but with an extensive number of thermocouples distributed across the section to determine char rates in different directions as a function of time. In the remaining three tests, the beams were loaded at 27%, 44%, and 91% of the design load. The reported allowable stresses were $F_b=2400$ psi and $E=1.6E6$ psi. Each beam was initially braced against lateral translation and rotation at the supports and at 2 evenly spaced loading blocks that were supported by the furnace lid; therefore, an effective length, $l_e=1.68 l_u$ (l_u = full span/3), was assumed. However, near the end of the 44% and 91% loaded beam fire tests, the beam deflected enough that the loading blocks dropped below the furnace lid, resulting in a change to the effective braced length, $l_e=1.84 l_u$ (l_u = full span). Using the NDS behavioral equations, the allowable resisting moment was estimated to be 71,900 ft-lb compared to induced moments of 19,500 ft-lb, 31,300 ft-lb and 65,700 ft-lb for the 27%, 44%, and 91% ASD design load cases, respectively. The corresponding failure times were 147 min, 114 min, and 85 minutes, respectively.

Results of Analysis

The section dimensions, average densities, allowable resisting moment and induced moment for the seven beam tests are summarized in Table 2.2. The measured times to structural failure are compared to calculated results are also provided in Table 2.2 and in Figure 2-1.

Table 2.2 Sawn and Glulam Timber Beam Tests

Designation	Breadth (in)	Depth (in)	Specific Gravity	ASD Stress Ratio	Measured (Structural) t_f (min)	Calculated (Structural) t_f (min)
TRADA	5.5	9	0.49	0.80	53	52 ¹
NFoPA	8.75	16.5	0.47	0.76	86	86 ¹
FCNSW-BB	5.9	16.5	0.82	1.39	59	60 ²
FCNSW-RP	5.9	16.5	0.52	0.53	67	63 ³
AF&PA-27	8.75	16.5	0.47	0.27	147	142 ¹
AF&PA-44	8.75	16.5	0.47	0.44	115	117 ¹
AF&PA-91	8.75	16.5	0.47	0.91	85	80 ¹

¹ Calculated assuming a nominal char rate of 1.5 inches/hr.

² Calculated assuming a measured a char rate of 1.06 inches/hr.

³ Calculated assuming a measured a char rate of 1.77 inches/hr.

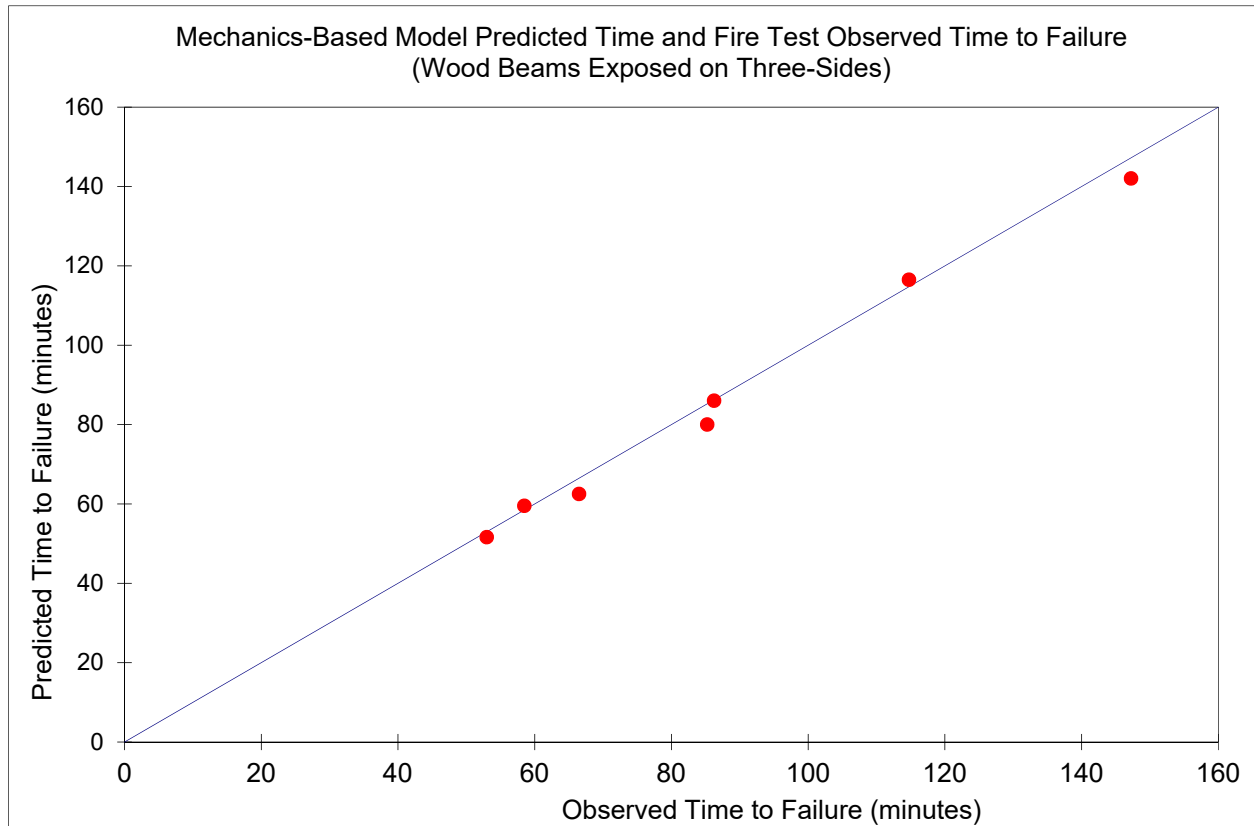

Figure 2-1 Comparison of Predicted to Observed Time to Failure (Wood beams exposed on three sides)

2.3 Columns

Fackler reported results for 5 columns that were fire tested in the early 1960's at the laboratories of CSTB in France [6]. Two columns were glued-laminated, and the remaining three were bolted or nailed together. The two glulam columns were identical except for the type of adhesive. For one column, the laminates were glued together with a melamine adhesive. For the other column, a urea-formaldehyde adhesive was used. It was concluded that the type of adhesive did not influence fire performance, because time to failure was identical for the two tests. Based on estimates of average ultimate bending strength and average E for French Maritime pine reported in the literature [19], allowable stresses for use with NDS provisions were estimated as $F_c = 1000$ psi and $E = 1.6E6$ psi. The columns were 7 inches x 7-7/8 inches and had an unbraced length of 90 inches. The columns were loaded concentrically through steel plates at each end. For design purposes, the columns were designed by Fackler assuming the columns were pinned at each end; however, analysis of the results suggest that the bearing moment created by concentrically-loaded wood columns with square-cut ends bearing on rigid plates such as found in a fire test laboratory would result in an effective length, l_e , of approximately $0.7l_u$. For analysis purposes in this report, the effective length was estimated to be $l_e = 0.7l_u$. Using NDS behavioral equations and an effective length $l_e=63$ inches, the allowable resisting capacity was estimated to be 50,500 lb compared to an induced load of 39,800 lb.

Stanke et al. reported results for 12 sawn lumber columns and 56 glulam columns that were

tested in Germany in the 1970's [7]. Two types of adhesives were used; resorcinol (R designation), and urea based (H designation). As in the French tests, it was found that type of adhesive did not have a measurable effect on fire resistance. Load ratios reported by Stanke et al. were 1.00, 0.75, and 0.50. Average ultimate compression strengths and E values for small clear specimens were reported for some column tests, but design properties were estimated by comparing assumed design properties from DIN 1052-1969 [62] with current design properties for North American species in the NDS Supplement [9]. For use with NDS provisions, allowable stresses for sawn lumber columns were estimated as $F_c = 675$ psi and $E = 1.4E6$ psi and allowable stresses for glulam columns were estimated as $F_c = 1350$ psi and $E = 1.85E6$ psi. For analysis purposes, the effective length was estimated to be $l_e = 0.7l_u$. Using the NDS behavioral equations and an effective length $l_e=101$ inches, the allowable resisting capacity for each column was estimated and compared to induced load. ASD design capacities, induced loads, and ASD stress ratios are reported in Table 2.3

Malhotra and Rogowski reported results for 16 glulam column tests that were conducted at the Fire Research Station in the United Kingdom [8]. The tests were statistically designed to determine the effect of 4 variables. The variables were:

- species (first letter in designation): Douglas fir (F), Western hemlock (H), European redwood (Scots pine) (R), and Western red cedar (C);
- adhesive (second letter in designation): urea (U), casein (C), resorcinol (R), and phenolic (P);
- shape: 9 in. x 9 in., 12 in. x 6.9 in., and 15 in. x 5.6 in.; and
- test load: 100% of design, 50% of design, and 25% of design.

Statistical analysis indicated that some columns with casein adhesive performed below average. Since these adhesives are not used today for North American glulam, the test data were discarded for this analysis. The load ratios were reported by Malhotra and Rogowski as 1.00, 0.50, and 0.25. In addition, Malhotra and Rogowski specifically recommended using $l_e = 0.7l_u$. Assuming that the test specimens were fabricated using #1 grade lumber, ASD design stresses from the NDS Supplement were assigned to the tested species as follows:

Douglas fir (F)	$F_c = 1500$ psi	$E = 1.7E6$ psi
Western hemlock (H)	$F_c = 1350$ psi	$E = 1.5E6$ psi
Scots pine (R)	$F_c = 1050$ psi	$E = 1.4E6$ psi
Western red cedar (C)	$F_c = 825$ psi	$E = 1.0E6$ psi

Using the NDS design values, the NDS behavioral equations, and an effective length $l_e=82$ inches, the allowable resisting capacity for each of the columns was estimated and compared to the induced load. ASD design capacities, induced loads, and ASD stress ratios are reported in Table 2.3.

Results of Analysis

The section dimensions, allowable column capacities and induced loads for the 82 column tests are summarized in Table 2.3. The measured times to structural failure compared to calculated results are also provided in Table 2.2 and in Figure 2-2a. Note that, while use of $l_e = 0.7l_u$ appears to fit the test results best on average, the ability of the mechanics-based model to predict each test

result varied widely. This variability is likely due to several issues that make testing of columns difficult, including out-of-straightness of the column, imprecise alignment of loading apparatus causing load eccentricities, and slight inaccuracies in the square-cut at each column end. To demonstrate this point, Figure 2-2b shows the same tests run with $l_e = l_u$.

Table 2.3 Sawn and Glulam Timber Column Tests

Designation	Depth (in)	Breadth (in)	ASD Resisting Capacity (kips)	Induced Load (kips)	ASD Stress Ratio (lb)	Measured (Structural) f_t (min)	Estimated (Structural) f_t (min) ¹
CSTB44	7.0	7.9	53.1	39.8	0.75	49	48
CSTB45	7.0	7.9	53.1	39.8	0.75	49	48
V14A	5.5	5.5	17.6	14.7	0.84	23	23
V14B	5.5	5.5	17.6	14.7	0.84	20	23
V14C	5.5	5.5	17.6	7.4	0.42	34	36
V14D	5.5	5.5	17.6	7.4	0.42	26	36
V16A	6.3	6.3	24.0	22.7	0.95	23	27
V16B	6.3	6.3	24.0	22.7	0.95	20	27
V20A	7.9	7.9	39.3	43.5	1.11	23	35
V20B	7.9	7.9	39.3	43.5	1.11	38	35
V20C	7.9	7.9	39.3	43.5	1.11	38	35
V20D	7.9	7.9	39.3	43.5	1.11	25	35
V24A	9.5	9.5	57.8	69.7	1.21	34	42
V24B	9.5	9.5	57.8	69.7	1.21	31	42
R12/16A	4.7	6.3	34.0	13.8	0.41	31	29
R12/16B	4.7	6.3	34.0	13.8	0.41	30	29
H12/16A	4.7	6.3	34.0	13.8	0.41	35	29
H12/16B	4.7	6.3	34.0	13.8	0.41	34	29
H12/30	4.7	11.8	63.7	26.1	0.41	43	31
H12/46A	4.7	18.1	97.7	40.0	0.41	38	33
H12/46B	4.7	18.1	97.7	40.0	0.41	41	33
R14A	5.5	5.5	37.2	19.0	0.51	29	32
R14B	5.5	5.5	37.2	19.0	0.51	21	32
R14C	5.5	5.5	37.2	9.5	0.26	36	42
R14D	5.5	5.5	37.2	14.3	0.38	29	36
H14A	5.5	5.5	37.2	19.0	0.51	26	32
H14B	5.5	5.5	37.2	19.0	0.51	27	32

H14C	5.5	5.5	37.2	9.5	0.26	43	42
H14D	5.5	5.5	37.2	14.3	0.38	34	36
H14/24A	5.5	9.5	63.7	32.6	0.51	35	36
H14/24B	5.5	9.5	63.7	32.6	0.51	32	36
H14/30A	5.5	11.8	79.7	40.8	0.51	39	37
H14/30B	5.5	11.8	79.7	20.4	0.26	59	49
H14/30C	5.5	11.8	79.7	20.4	0.26	53	49
H14/40	5.5	15.8	106.2	54.3	0.51	43	38
R15A	5.9	5.9	43.5	24.0	0.55	28	35
R15B	5.9	5.9	43.5	24.0	0.55	27	35
H15A	5.9	5.9	43.5	24.0	0.55	31	35
H15B	5.9	5.9	43.5	24.0	0.55	30	35
R16	5.9	5.9	50.2	29.4	0.59	30	38
H16A	6.3	6.3	50.2	29.4	0.59	31	38
H16B	6.3	6.3	50.2	29.4	0.59	37	38
R16/30	6.3	11.8	94.1	27.6	0.29	58	58
H16/30A	6.3	11.8	94.1	55.1	0.59	40	45
H16/30B	6.3	11.8	94.1	55.1	0.59	52	45
H16/30C	6.3	11.8	94.1	55.1	0.59	45	45
H16/30D	6.3	11.8	94.1	27.6	0.29	57	58
R20A	7.9	7.9	80.8	56.4	0.70	34	53
R20B	7.9	7.9	80.8	56.4	0.70	48	53
R20C	7.9	7.9	80.8	28.2	0.35	64	71
R20D	7.9	7.9	80.8	28.2	0.35	61	71
H20A	7.9	7.9	80.8	56.4	0.70	42	53
H20B	7.9	7.9	80.8	56.4	0.70	43	53
H20C	7.9	7.9	80.8	28.2	0.35	60	71
H20D	7.9	7.9	80.8	28.2	0.35	52	71
H20/40A	7.9	15.8	161.5	112.9	0.70	65	63
H20/40B	7.9	15.8	161.5	112.9	0.70	74	63
H24A	9.5	9.5	117.8	89.9	0.76	60	67
H24B	9.5	9.5	117.8	89.9	0.76	60	67
H26A	10.3	10.3	138.8	110.7	0.80	62	74
H26B	10.3	10.3	138.8	110.7	0.80	62	74
R27A	10.6	10.6	149.9	121.0	0.81	57	78

R27B	10.6	10.6	149.9	121.0	0.81	54	78
R27C	10.6	10.6	149.9	121.0	0.81	76	78
H27A	10.6	10.6	149.9	121.0	0.81	59	78
H27B	10.6	10.6	149.9	121.0	0.81	56	78
H27C	10.6	10.6	149.9	121.0	0.81	71	78
H28A	11.0	11.0	161.4	132.9	0.82	59	81
H28B	11.0	11.0	161.4	132.9	0.82	67	81
H40	15.8	15.8	332.3	308.6	0.93	114	117
FU1	9.0	9.0	120.6	72.0	0.60	55	76
FR3	5.6	15.0	115.4	36.0	0.31	74	50
FP4	9.0	9.0	120.6	144.0	1.19	45	43
HU5	9.0	9.0	108.5	31.0	0.29	73	98
HR7	6.9	12.0	107.5	62.0	0.58	49	56
HP8	9.0	9.0	108.5	62.0	0.57	69	77
RU9	5.6	15.0	82.0	55.2	0.67	47	39
RR11	9.0	9.0	84.7	110.5	1.30	45	39
RP12	6.9	12.0	84.3	27.6	0.33	76	71
CU13	6.9	12.0	65.9	89.5	1.36	35	30
CR15	9.0	9.0	66.5	44.8	0.67	43	71
CP16	5.6	15.0	63.9	44.8	0.70	39	36

¹ Assumed a nominal char rate of 1.5 in/hr.

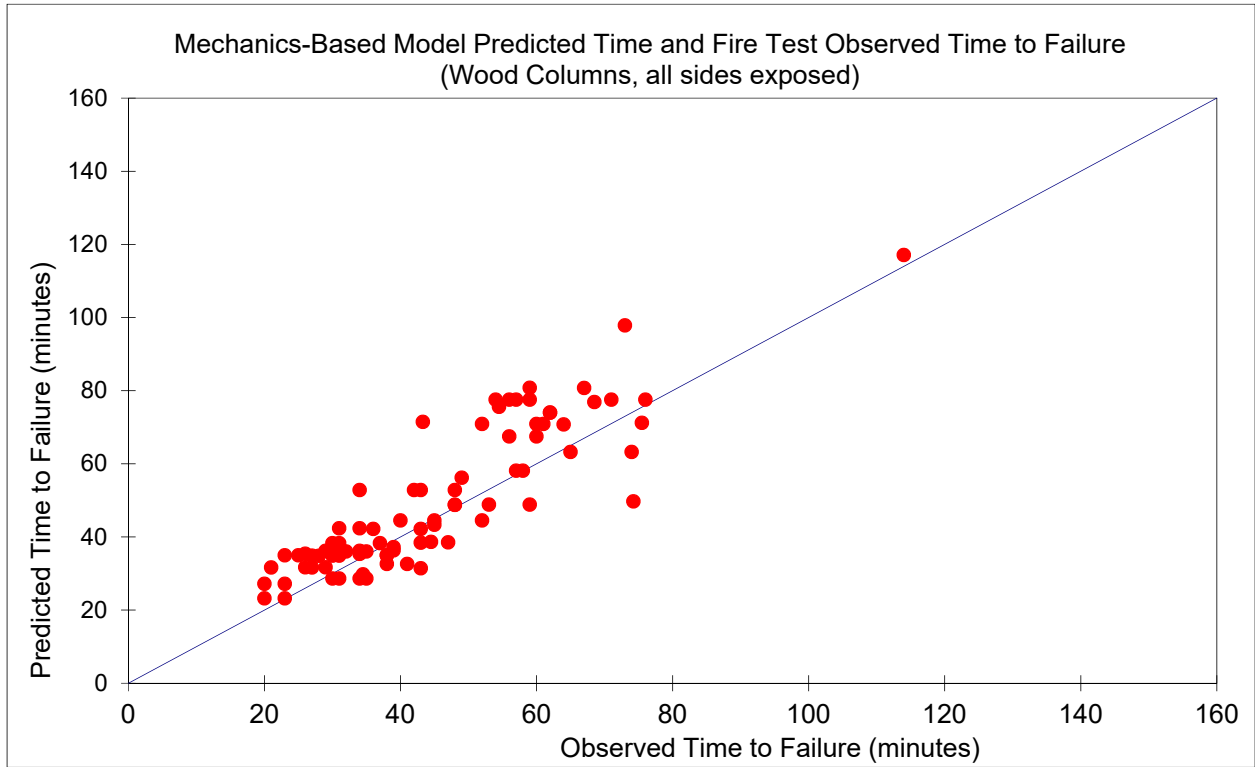

Figure 2-2a Comparison of Predicted to Observed Time to Failure (Wood columns all sides exposed), $l_e = 0.7l_u$

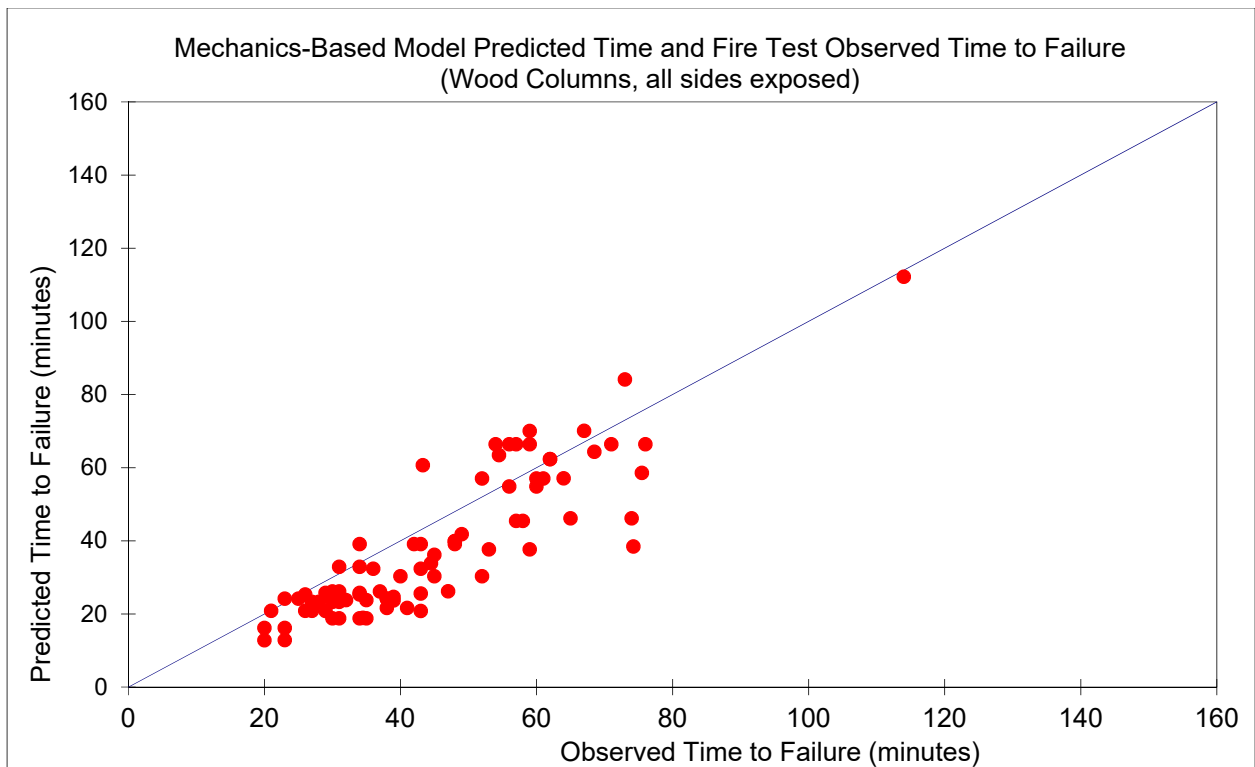

Figure 2-2b Comparison of Predicted to Observed Time to Failure (Wood columns all sides exposed), $l_e = l_u$

2.4 Tension Members

For fire tests of tension members, the U.S. Forest Products Laboratory (FPL) installed a horizontal furnace between the tension heads of a full-scale tension test apparatus. The center 72 inches of the tested member span extended through the intermediate-scale horizontal furnace. For the series of tests in this report, the specimens were subjected to an ASTM E119 exposure.

In 1990, FPL conducted eleven tension tests of southern pine #1 Dense grade 2x4 lumber [61]. Six of the members were tested at half ASD design load and five were tested at full ASD design load. A summary the average results from these tests were reported and are also included in Tables 2.4a, 2.4b, and Figure 5.

In 2000, the American Wood Council sponsored a series of four tension member tests at FPL [27]. The primary objective of these tests was to validate this mechanics-based model against full-size tests of exposed wood members. The Douglas fir members were 117 inches long and loaded with the full-scale tension test apparatus. Due to a limitation in the furnace opening width, members were limited to less than 9 inches in width. To accommodate this limitation and to test members for up to two hours, allowable load ratios in the range of 0.15-0.48 were used. In the first two tests, it was determined that there was an unintended eccentricity caused by the bolted connection of the member to the test apparatus that resulted in a moment being induced in the member. This eccentricity resulted in a small moment in the first test of the 4x6 member, but induced a particularly large moment in the second test; therefore, the second test was not included in the analysis. The eccentricity was corrected prior to the third test and a fourth test was conducted to repeat the configuration of the second test but with the unintended eccentricity removed. Correcting the unintended eccentricity resulted in good agreement between the observed and predicted failure times.

Results of Analysis

Using NDS behavioral equations, resisting capacities were estimated for each of the tension members. The section dimensions, mechanical properties, resisting capacities and induced loads for tension members are provided in Table 2.4a. The measured times to structural failure are compared to calculated results in Table 2.4b and in Figure 2-4.

Table 2.4a Tension members tested

Designation	Breadth (in)	Depth (in)	F_t (psi)	ASD Resisting Capacity (kips)	Induced Load (kips)
Southern pine lumber 2x4 (n=6)	1.5	3.5	1100	5.8	3.3
Southern pine lumber 2x4 (n=5)	1.5	3.5	1100	5.8	6.6
Douglas fir Lumber 4x6	3.4	5.3	2130	13.4	3.2
Douglas fir Glulam 5-1/8 x 9	5.1	8.8	4560	71.4	35.2
Douglas fir Glulam 8-3/4 x 9	8.8	8.6	4560	119.9	19.6 ¹

¹ For this test, a constant load of 6,000 lb was applied for the first 120 minutes of the test. After 120 minutes, the load was gradually increased until failure occurred.

Table 2.4b Measured and Calculated Tension Member Fire Resistance Times

Designation	ASD Stress Ratio	Measured (Structural) t_f (min)	Calculated (Structural) t_f (min) ¹
Southern pine lumber 2x4 (n=6, COV = 0.17)	0.50	13 ²	14
Southern pine lumber 2x4 (n=5, COV = 0.17)	1.00	10 ²	10
Douglas fir Lumber 4x6	0.24	42	44
Douglas fir Glulam 5-1/8 x 9	0.49	58	60
Douglas fir Glulam 8-3/4 x 9	0.16	124	126

¹ Assumed a nominal char rate of 1.5 in/hr.

² Individual test results were not reported. Value is an average.

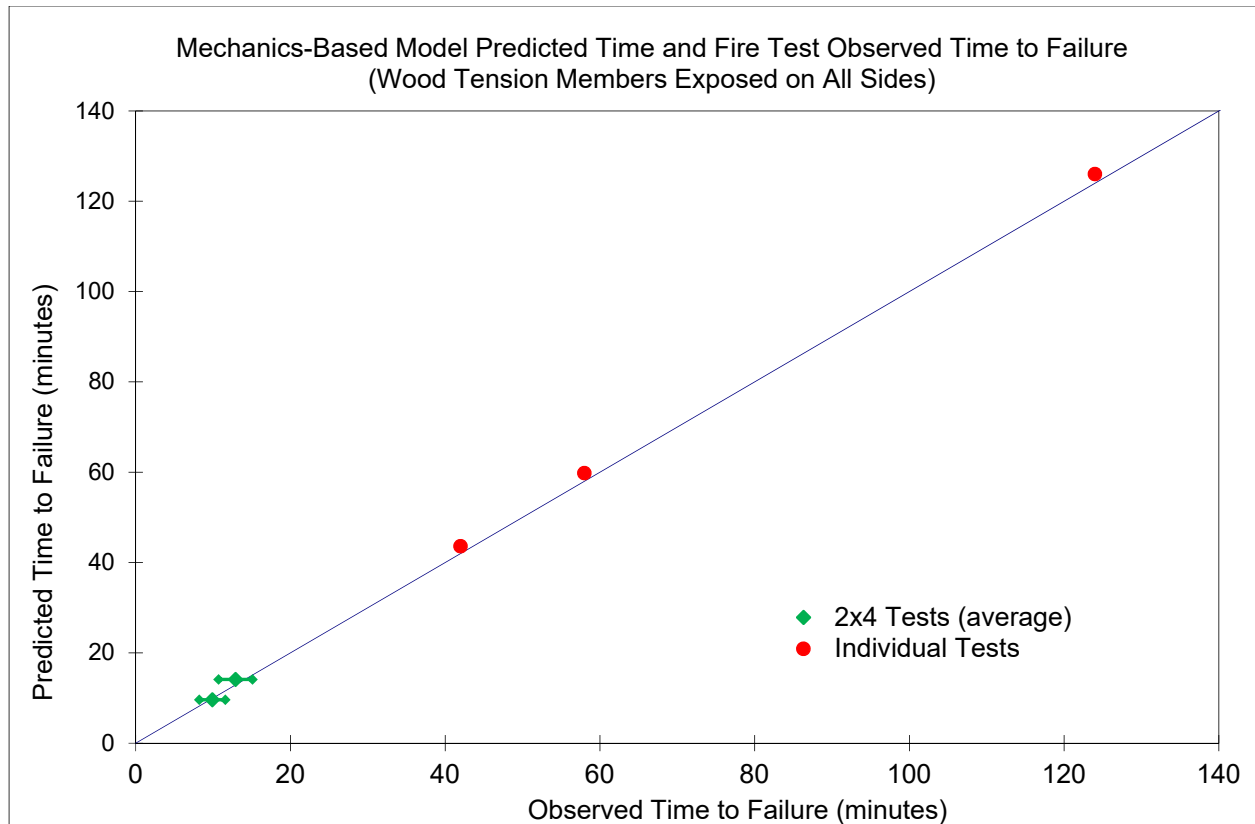

Figure 2-4 Comparison of Predicted to Observed Time to Failure (Wood tension members exposed on four sides)

2.5 Decking

In 1964, Underwriters' Laboratories (UL) conducted a series of four tests on roof constructions for the Douglas Fir Plywood Association (now APA - The Engineered Wood Association) [21]. Two of the tests, referred to as UL#2 and UL#4, were conducted on exposed timber decks consisting of 5.5 in x 1.5 in single tongue-and-groove Douglas fir planks. The decks were loaded to 46% and 59% of the design load for tests UL#2 and UL#4 respectively. The reported thermal penetration time (either excessive temperature rise or flame-through) was identical for the two tests at 20 min. First structural failure of a plank is not specifically mentioned in the report. However, for test UL#2 it is mentioned that deflection was noticeable (1.25 in. at the center of the deck) 13 minutes after the start of the test, and that the unsupported ends of some planks started to warp at 24 minutes. For test UL#4, noticeable deflection was observed at 11 minutes and warping was observed at 18 minutes.

In 1969, the American Iron and Steel Institute conducted a comprehensive experimental program at Ohio State University (OSU) [22]. The program included six tests on exposed timber floor decks. The first two decks, referred to as HT1 and HT2, consisted of 1.625 in. x 3.625 in. members on edge and covered with $\frac{3}{4}$ in. wood flooring. Flame-through for the two tests was reported at 61 and 69 minutes respectively. The first two decks were loaded at 31% of design load, and structural failure of the decking (not total structural failure) was reported at 62 minutes and 56 minutes for HT1 and HT2, respectively. Heavy charring occurred on the bottom of the decking, while lighter charring occurred on the sides. To use the mechanics-based model, charring on the sides due to the partial exposure at the butt-joints was addressed by assuming a charring rate of 30% of the effective charring rate for wood which is fully exposed.

The remaining four decks, referred to as HT3 through HT6, consisted of 5.625 in. x 2.625 in. tongue-and-groove planks, covered with $\frac{3}{4}$ " wood flooring. Flame-through for the four tests was reported at 54, 31, 35, and 49 minutes respectively. The HT3 and HT4 decks were loaded at 42% of design load, and structural failure was reported at 54 minutes for HT3 (and not reported for HT4). The HT5 and HT6 decks were loaded at 50% of design load, and structural failure was reported at 45 minutes for HT6 (and not reported for HT5). Note that fuel supplied to the furnace burners was controlled during the even-numbered tests rather than following the ASTM E119 standard time-temperature curve. This resulted in slightly more severe exposure conditions than in the odd-numbered tests, which were conducted strictly according to ASTM E 119.

Using the 2.85 allowable design stress to average ultimate strength adjustment factor derived in Chapter 1, the ratio of induced moment to average ultimate bending moment is used to estimate the structural fire resistance for each deck configuration. The section dimensions, ASD stress ratio, measured structural failure time and calculated failure time are summarized in Table 2.5 and Figure 2-5.

Table 2.5 Measured and Calculated Decking Structural Fire Resistance Times

Designation	Species	Breadth (in)	Depth (in)	ASD Stress Ratio	Measured (Structural) t_f (min)	Calculated (Structural) t_f^1 (min)
UL#2	Douglas fir	5.5	1.5	0.46	25 ²	25
UL#4	Douglas fir	5.5	1.5	0.59	25 ³	23
HT1	Subalpine fir	1.625	3.625	0.31	62	52
HT2	Subalpine fir	1.625	3.625	0.31	56	52
HT3	Southern pine	5.625	2.625	0.42	54	53
HT4	Southern pine	5.625	2.625	0.42	NR	53
HT5	Southern pine	5.625	2.625	0.50	NR	49
HT6	Southern pine	5.625	2.625	0.50	45	49

NR=Not Reported

¹ Assumed a nominal char rate of 1.5 in/hr.

² Unsupported end of a tongue & groove deck plank warped into furnace at 24 minutes, but the assembly continued to carry load.

³ Unsupported end of a tongue & groove deck plank warped into furnace at 18 minutes, but the assembly continued to carry load.

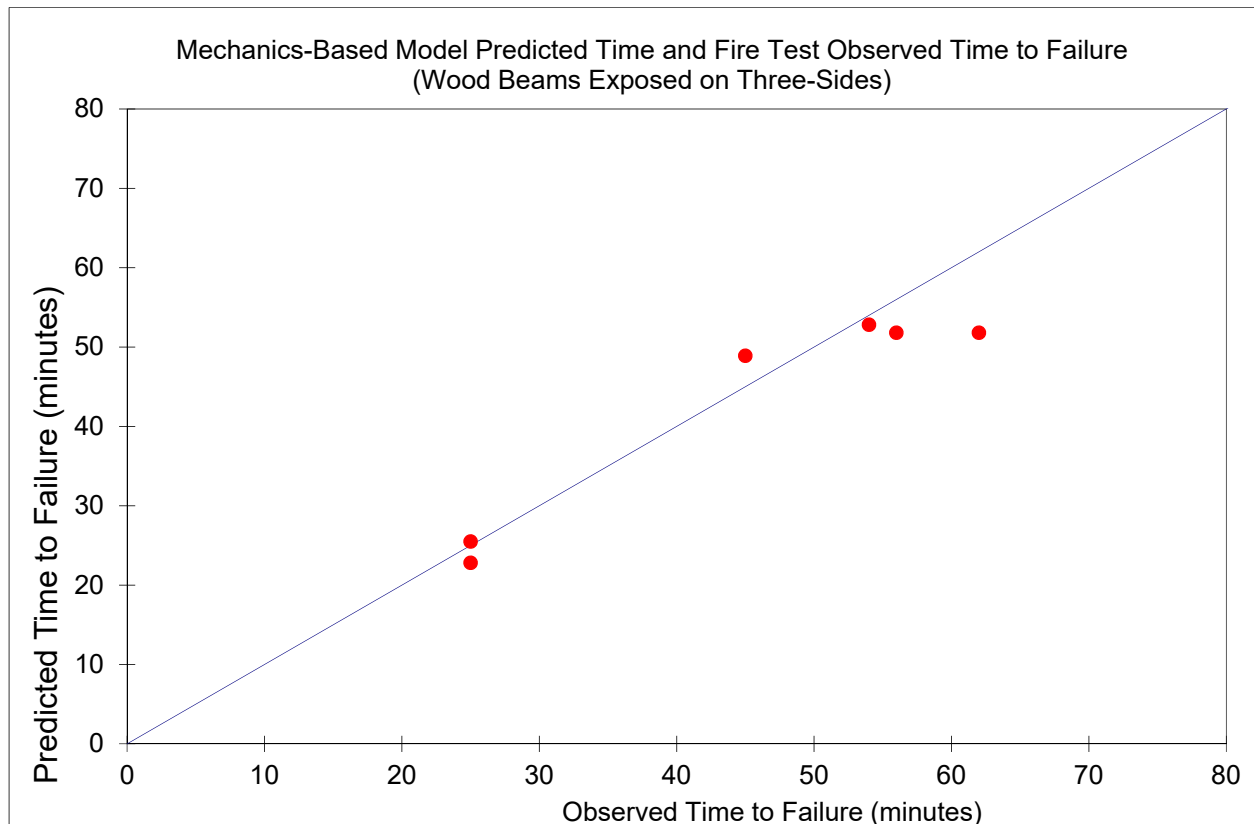

Figure 2-5 Comparison of Predicted to Observed Time to Failure (wood decking primarily exposed on one side)

2.6 Unprotected Floor Joists

Several fire resistance tests of exposed wood joist floor assemblies have been conducted over the last 40 years. In review of these tests, the procedure derived in Chapter 1 has been found to be applicable to light-frame wood members. A summary of each of the 21 tests reviewed and the assumptions used to calculate the fire resistance times for these assemblies are provided.

National Bureau of Standards Tests

In 1971, B. C. Son with the U.S. Department of Commerce, National Bureau of Standards (NBS – now the National Institute of Standards and Technology) conducted a series of full-scale and small-scale fire resistance tests on unprotected floor assemblies [28]. All tests followed the E119 time-temperature curve. One full-scale floor assembly utilized nominal 2x10 sawn lumber joists spaced 16 inches on center. A second full-scale floor assembly utilized nominal 2x8 sawn lumber joists also spaced 16 inches on center. Design values and dimensions for 2x8 and 2x10 joists were taken from FHA No. 300: *Minimum Property Standards for One and Two Living Units*; however, upon review of the report, it appears the writers did not know what was actually tested, as they stated, “To avoid overloading the joists, the lumber was assumed to be Rocky Mountain Region Douglas Fir. This has an allowable stress level of 1050 psf in bending according to Table III page 250 of the FHA Minimum Property Standards (4).”

In 1971, lumber sizes and grades were standardized under U.S. Department of Commerce’s Voluntary Product Standard 20: *American Softwood Lumber Standard* (PS 20-70) [29]. Lumber sizes for dry 2x8’s were 1.5 inches x 7.25 inches and 2x10’s were 1.5 inches x 9.25 inches. Lumber grades had also been standardized and Construction grade was limited to 2x4 lumber. Lumber sizes and grades in the report appear to be for lumber available in the early to mid-1960’s, not likely tested in 1971.

As a result of the confusion about actual lumber sizes and grades tested, dimensions for both the 2x8 and 2x10 joists were based on PS 20-70. In addition, since the design values for Construction grade Douglas fir lumber were not recognized in 1971, design values for a common grade of lumber used for floor joists, #2 Douglas Fir – Larch (DFL), with a repetitive-member bending stress of 1450 psi, was used.

The 2x10 floor was sheathed with two layers of ½” plywood (Test #2). Half of the 2x10 floor assembly was also covered with carpet (Test #4). The 2x8 floor was sheathed differently on each half. One half of the 2x8 floor assembly was sheathed with a single layer of 5/8” tongue-and-groove plywood (Test #9). The other half of the floor assembly was sheathed with a single layer of ½” plywood with all edges blocked using 2x3 lumber (Test #10).

The dead load of the 2x10 floor assembly was estimated to be 6.8 psf. A superimposed load of 63.7 psf was added, resulting in a total load of 70.5 psf. Using NDS behavioral equations and standard dry dimensions of 1.5 inches x 9.25 inches, the allowable resisting moment was estimated to be 31,020 in-lb. Given a span of 163 inches, the induced moment was 25,910 in-lb (84% of full design load). Failure was recorded at 11:38 minutes.

The dead load of the 2x8 floor assembly was estimated to be 6.2 psf. A superimposed load of 21 psf was added, resulting in a total load of 27.2 psf. Using NDS behavioral equations and standard dry dimensions of 1.5 inches x 7.25 inches, the allowable resisting moment was estimated to be 19,050 in-lb. Given a span of 163 inches, the induced moment was 9,940 in-lb (52% of full design load). Failure was recorded at 13:00 minutes.

Factory Mutual Tests

In 1974, Factory Mutual witnessed a series of full-scale fire resistance tests conducted at the NGC Research Center. These tests were conducted on unprotected floor assemblies constructed with lumber joists, and all tests followed the E119 time-temperature curve. Two of the tests utilized nominal 2x10 sawn joists spaced 24 inches on center [30][31] and two of the tests utilized nominal 2x8 sawn joists spaced 16 inches on center [32][33].

Two of the Factory Mutual full-scale floor assemblies consisted of #2 MG (medium-grain) grade 2x10 Southern pine joists sheathed with a single layer of 23/32" plywood. The joists had an allowable bending stress for repetitive member assemblies of 1450 psi. The actual dimensions were reported as 1.5 inches x 9.125 inches. Test FC 209 was topped with vinyl tile flooring. Test FC 212 was topped with nylon carpet.

Dead loads of the 2x10 floor assemblies were estimated to be 4.7 psf and 4.8 psf for FC 209 and FC 212, respectively. Superimposed loads of 57.4 psf and 57.3 psf, respectively, were added to each assembly, resulting in a total load of 72.1 psf for both assemblies. Using NDS behavioral equations and measured dry dimensions of 1.5 inches x 9.125 inches, the allowable resisting moment of joists in both assemblies was estimated to be 30,180 in-lb. Given a span of 157 inches, the moment induced in joists of both assemblies was 31,890 in-lb (106% of full design load). Failure was recorded at 13:34 and 12:06 minutes for FC 209 and FC 212, respectively.

Two additional Factory Mutual full-scale floor assemblies that were tested consisted of #2 grade 2x8 Douglas fir sawn lumber joists sheathed with a single layer of 23/32" plywood. The joists had an allowable bending stress for repetitive member assemblies of 1450 psi. The actual dimensions were reported as 1.5 inches x 7.25 inches. Test FC 213 was topped with vinyl tile flooring. Test FC 216 was topped with nylon carpet.

Dead loads of the 2x8 floor assemblies were estimated to be 4.4 psf and 5 psf for FC 213 and FC 216, respectively. Superimposed loads of 53.3 psf and 52.7 psf, respectively, were added to each assembly, resulting in a total load of 57.7 psf for both assemblies. Using NDS behavioral equations and measured dry dimensions of 1.5 inches x 7.25 inches, the allowable resisting moment of joists in both assemblies was estimated to be 19,050 in-lb. Given a span of 157 inches, the moment induced in joists of both assemblies was 19,640 in-lb (102% of full design load). Failure was recorded at 10.2 and 12.9 minutes for FC 213 and FC 216, respectively.

NBS / HUD Tests

In 1982, NBS conducted a series of full-scale tests on selected residential floor assemblies for the U. S. Department of Housing and Urban Development (HUD) [34]. Two of the tests were conducted on unprotected floor assemblies constructed with lumber joists and followed the E119 time-temperature curve. The assemblies utilized nominal 2x8 sawn lumber joists spaced 24 inches on center. The 2x8 joists were #2 grade Southern pine lumber with an allowable bending stress for repetitive member assemblies of 1400 psi. The floors were sheathed with a single layer of 23/32" plywood (Test #6 & #7).

The dead load of the floor assembly was estimated to be 4.6 psf. A superimposed load of 54 psf was added, resulting in a total load of 58.6 psf. Using NDS behavioral equations and standard dry dimensions of 1.5 inches x 7.25 inches, the allowable resisting moment was estimated to be 18,400 in-lb. Given a span of 110 inches, the induced moment was 14,770 in-lb (80% of full design load). Failure was recorded at 14:42 minutes in Test #6 and 13:10 minutes in Test #7.

USDA Forest Product Laboratory Tests

In 1983, the U.S. Forest Product Laboratory (FPL) funded a series of full-scale fire

resistance tests on unprotected floor assemblies at Construction Technology Laboratories [35]. The floor assemblies were constructed with 2x10 sawn lumber joists spaced 16 inches on center. The tests all followed the E119 time-temperature curve fire exposure.

Materials for the floor assembly tests were obtained from a local lumber yard. Lumber joists were nominal 2x10 Douglas fir-Larch joists, but the grade of the material was not reported. Results from limited destructive bending tests (20 pieces) and non-destructive testing (161 pieces) of the materials were reported. The average bending strength of the 20-piece sample was 5,280 psi with a COV=0.47 and the average edgewise Modulus of Elasticity (E) was 1.5E6 psi with a COV=0.25. While this limited sample cannot be used to determine bending design values for this sample, it does indicate that the material was at or below current #2 grade DFL bending design values. To use the procedures developed in Chapter 1, calculations were conducted assuming current design values for #2 grade DFL with an allowable bending stress for repetitive member assemblies of 1140 psi. The actual dimensions were reported as 1.47 inches x 9.11 inches. The 2x10 floors were sheathed with a single layer of 23/32" plywood.

It should be noted that the 2.85 factor adjusts the allowable design stress to a lower bound estimate of the average ultimate strength based on the assumed COV of clear wood (16%) rather than the COV of 47% measured in the 20-piece full-size, as-graded lumber sample. This added conservatism in the design procedure ensures that the calculated fire resistance time is a reasonable lower bound even for wood materials with highly variable properties.

Using NDS behavioral equations and measured dry dimensions of 1.47 inches x 9.11 inches, the allowable resisting moment of the joists was estimated to be 23,150 in-lb.

Dead loads of the floor assemblies were estimated to be 4.5 psf for all tests. Superimposed loads of 11.4 psf on six low load tests and 79.2 psf on five high load tests were added to the assemblies, resulting in total loads of 15.9 psf and 83.7 psf, respectively. Given the reported span of 156 inches, the induced moment that was intended to be applied to the floor joists was 5,330 in-lb (23% of full design load) for the lightly-loaded floor assemblies and 28,400 in-lb (123%) for the heavily-loaded floor assemblies. However, the actual loading was much higher.

The loading apparatus used at Construction Technologies Laboratories consisted of 16 interconnected hydraulic rams. At the ends of the hydraulic rams, a three-legged tripod structure was used to apply the load to the floor assembly. This tripod system had been used on tests of two-way concrete slabs, but had not been tested on repetitive member "ribbed" assemblies, such as a wood joist floor assembly. For decades, these tests have been reviewed and the validity of the results questioned because of the difficulties associated with estimating the loading on the assemblies over time [36, 37]. Different attempts to model the load distribution have met with unanswered questions about stiffness of the sheathing, charring of the sheathing, and the ability of the sheathing to distribute loads. Clearly the loads were non-uniform since "rippling", characterized as deflections of the sheathing along the line of the application of the loading was observed in the high-load tests between 3 and 6 minutes. Analysis assuming that the sheathing was initially stiff enough to distribute the loads by bending to the joists indicates that the initial load on the joist directly under the ram would have been approximately 200% of the assumed load and that joists on either side would have received approximately 50% of the assumed load. When this same analysis is conducted assuming sheathing had charred to the point that it could not distribute the load by bending, the load on the joist under the ram drops to 150% of the assumed load, and the joists on either side would increase to approximately 75% of the assumed load. Assuming that the latter case represents a lower bound estimate of the load on joists under the rams, the induced moments in these joists was assumed to be 150% of the induced moments assuming a uniform load. As a result, the apparent induced moment on the critical joists under the rams was estimated to be 8,000 in-lb (35% of full design load) in the lightly-loaded tests and 42,590 in-lb (184% of

full design load) in the highly-loaded tests. First-joist failures ranged from 16.7 to 18.5 minutes in the lightly-loaded tests and 5.5 to 7.5 in the highly-loaded tests. Floor assembly failure times were typically more than first-joist failure times, but due to non-uniform loading conditions on the joists, those failure times were not included in this analysis.

Underwriters' Laboratory Tests

In 2008, Underwriters' Laboratory (UL) conducted a series of full-scale fire resistance tests of unprotected floor assemblies [38]. For this series of tests, the loads placed on the floor assemblies were intended to represent typical loading conditions during a fire. A load of 40 psf was placed along two of the four perimeter sides of the floor assembly and two 300-pound concentrated loads were placed near the center of the assembly to represent two fire service personnel on the floor. One of the tests was a full-scale sawn floor assembly with a non-uniform loading pattern on portions of the floor. The test followed the E119 time-temperature curve fire exposure.

The floor assembly consisted of #2 grade 2x10 Spruce-Pine-Fir (SPF) sawn lumber joists spaced at 16 inches on center and sheathed with a single layer of 1x6 subflooring and topped with 1x4 wood flooring. The joists had an allowable bending stress for repetitive member assemblies of 1110 psi. Actual dimensions were reported as 1.5 inches x 9.125 inches. Dead load of the 2x10 floor assembly was estimated to be 6 psf. As previously noted, a target uniform load of 40 psf was applied at the perimeter edge of two intersecting sides of the floor; however, due to proximity of the load to the joist bearing reaction on one edge of the floor and the use of three joists at the end of the floor assembly, the effective loads on the interior joists were likely much less than reported. In fact, deflection measurements taken during the test suggest that joists at the end of the assembly were only loaded to approximately the same level as joists in the middle of the floor assembly; therefore, all calculations were done assuming that the maximum load ratios were those reported at the middle joists. Using NDS behavioral equations and measured dry dimensions of 1.5 inches x 9.125 inches, the allowable resisting moment was estimated to be 23,040 in-lb. Given a span of 155 inches, the induced moment was estimated to be 7,760 in-lb (34% of full design load). Failure was recorded at 18.75 minutes.

In 2011, UL conducted another series of full-scale fire resistance tests of unprotected floor assemblies [39]. For this series of tests, a uniform load was used. Two of the tested floor assemblies utilized sawn lumber. Floor assembly #6 used #2 grade Douglas Fir-Larch 2x10 joists and appeared to be loaded at approximately 91% of design load. In Test #6, the furnace temperature was initially allowed to run at temperatures nearly 50% higher than the E119 time-temperature curve specified and resulted in failure at approximately 7 minutes. Since the furnace temperature was not controlled at the standard E119 conditions assumed in this model, this test results were not included in this analysis.

Floor assembly #7 utilized 2x8 Douglas fir joists taken from deconstruction of a circa 1940 home in Ohio. The grade of the material was not known, but based on the time period and using the mid-quality grade of Douglas fir joists reported in the 1944 NDS [40], Structural grade Douglas fir 2x10 joists were assumed with an allowable bending design value of 1900 psi. Actual dimensions were reported as 1.75 inches x 7.56 inches. The floor was sheathed with a single layer of 23/32 OSB sheathing.

Dead load of the 2x8 floor assembly was estimated to be 4.5 psf. A superimposed load of 42.3 psf was added, resulting in a total load of 46.8 psf. Using NDS behavioral equations and reported dimensions of 1.75 inches x 7.56 inches, the allowable resisting moment of the joists was estimated to be 31,670 in-lb. Given a span of 155 inches, the induced moment was 15,690 in-lb (50% of full design load). Failure was recorded at 18.1 minutes.

Results of Analysis

The fire resistance of joists from each of the unprotected floor joist assemblies is provided in Table 2.6 and Figure 2-6. On average, the calculated fire resistance times conservatively underpredicted actual observed fire resistance times by approximately 1 minute, ranging from a maximum underprediction of 2.8 minutes to a maximum overprediction of 2.2 minutes (see Table 2.6).

Given the previously discussed loading issues and uncertainty in resistance estimates, the higher variability of this analysis was expected. In addition, the model is expected to under-predict fire resistance times since the model underestimates the average ultimate strength for wood members that have higher property variability, such as sawn lumber joists.

Table 2.6 Measured and Calculated Floor Joist Structural Fire Resistance Times

Designation	Species	Breadth (in)	Depth (in)	ASD Stress Ratio	Measured (Structural) t_f (min)	Calculated (Structural) t_f ¹ (min)
NBS#2 & #4	Douglas fir	1.5	9.25	0.84	11.6	12.5
NBS#9 & #10	Douglas fir	1.5	7.25	0.52	13.0	15.2
FC 209	Southern pine	1.5	9.13	1.06	13.6	10.8
FC 212	Southern pine	1.5	9.13	1.06	12.1	10.8
FC 213	Douglas fir	1.5	7.25	1.03	10.2	11.0
FC216	Douglas fir	1.5	7.25	1.02	12.9	11.0
NBSIR #6	Southern pine	1.5	7.25	0.80	14.7	12.6
NBSIR #7	Southern pine	1.5	7.25	0.80	13.2	12.6
FPL Trial	Douglas fir	1.5	9.11	0.35	16.7	16.5
FPL #1	Douglas fir	1.47	9.11	0.35	17.8	16.5
FPL #2	Douglas fir	1.47	9.11	0.35	16.8	16.5
FPL #3	Douglas fir	1.47	9.11	0.35	18.0	16.5
FPL #4	Douglas fir	1.47	9.11	0.35	18.4	16.5
FPL #5	Douglas fir	1.47	9.11	0.35	18.5	16.5
FPL #6	Douglas fir	1.47	9.11	1.84	6.2	4.8
FPL #7	Douglas fir	1.47	9.11	1.84	6.8	4.8
FPL #8	Douglas fir	1.47	9.11	1.84	7.5	4.8
FPL #9	Douglas fir	1.47	9.11	1.84	5.5	4.8
FPL #10	Douglas fir	1.47	9.11	1.84	6.3	4.8
UL NC9140#1	Spruce-Pine-Fir	1.5	9.13	0.34	18.8	17.0
UL 2011#7	Douglas fir	1.75	7.56	0.50	18.1	18.4

¹ Assumed a nominal char rate of 1.5 in/hr.

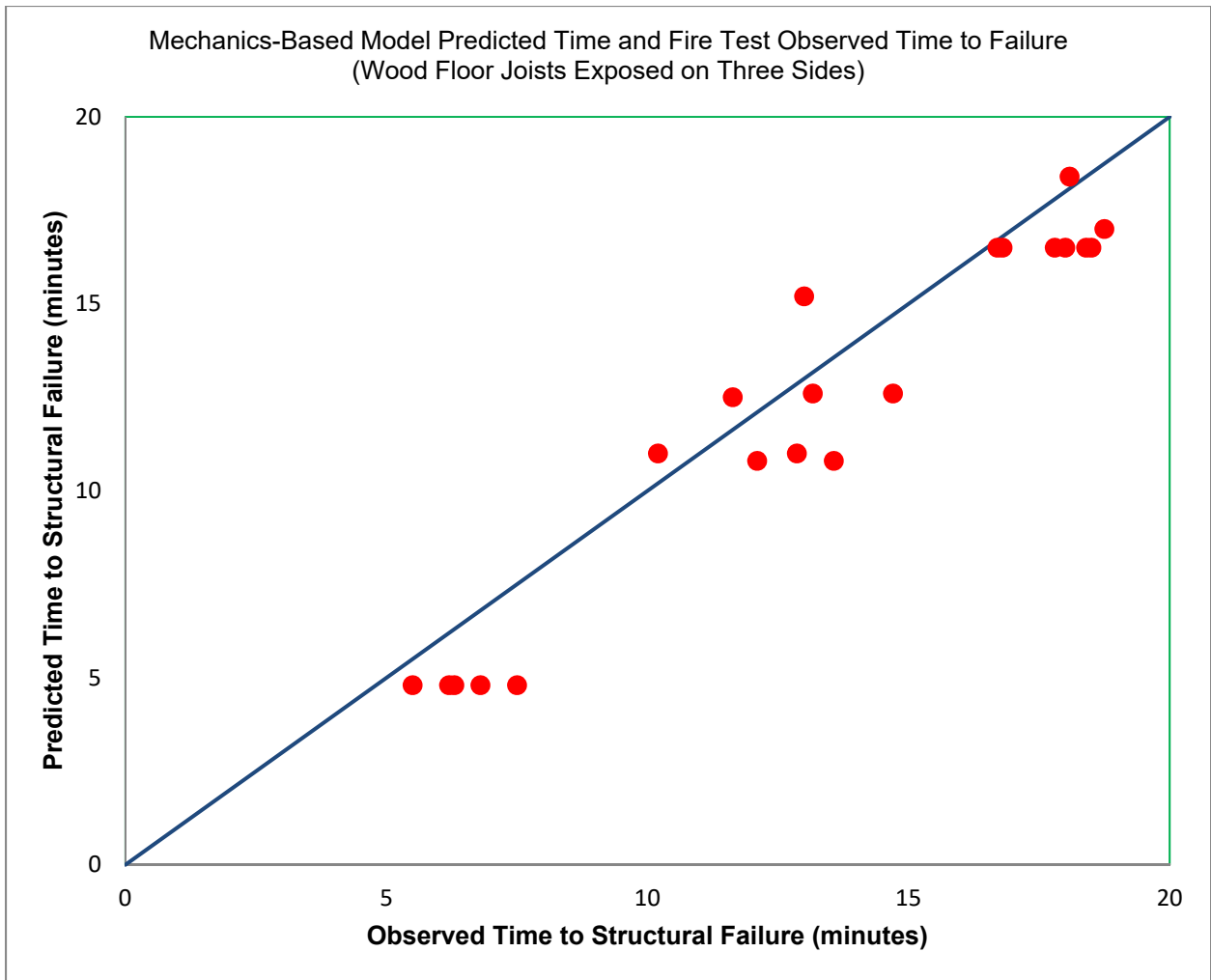

Figure 2-6 Comparison of Predicted to Observed Time to Failure (Floor joists Exposed on Three sides)

2.7 Structural Composite Lumber

Over the last decade, a number of public and proprietary tests have been conducted to demonstrate that the procedures in Chapter 1 of this report can be used to design Structural Composite Lumber (SCL) manufactured in accordance with requirements of ASTM D5456 [41] and designed in accordance with NDS provisions. This section contains a summary and analysis of test results that have been made available. SCL products tested include laminated strand lumber (LSL), laminated veneer lumber (LVL) and parallel strand lumber (PSL).

FPL Tension Tests

In 2006, White reported on fire resistance testing of SCL at FPL [42]. Fourteen SCL products were exposed to a standard E119 time-temperature curve in a small vertical furnace to determine the one-dimensional char rate for each product. Char rates were determined to be in the range expected for other wood products. Ten of these SCL products were then tension tested in the FPL intermediate-scale furnace while being exposed to the E119 time-temperature curve. These fire resistance tests utilized the same configuration as the sawn lumber and glued-laminated timber tension tests reported in section 2.4 of this report.

In reviewing intermediate-scale tension test data, it was noted that some larger LVL cross-sections appeared to fail earlier than expected. In consultation with the SCL manufacturers and FPL staff, it was determined that some of the thicker LVL cross-sections were made from thinner LVL that were then field-glued by an unknown third party. The type of adhesives and the quality of the bond was also unknown. In at least some cases, it was suspected that the secondary bond lines failed prematurely, causing char to fall off and increasing the effective char rate; therefore, for purposes of this analysis, all of the test results for specimens with secondary bond lines were excluded. In addition, one test of an experimental product in the study was also excluded. All other specimens were analyzed as solid cross-sections using the provisions of this report. The measured times to structural failure are compared to calculated results in Table 2.7A and in Figure 2-7.

Table 2.7A Measured and Calculated SCL Tension Member Structural Fire Resistance Times

Test No.	Designation	Species	SCL Width (in.)	SCL Depth (in)	ASD Stress Ratio	Measured (Structural) t_f (min)	Calculated (Structural) t_f^1 (min)
2	LVL #3	Aspen	1.65	9.53	0.64	13	16
5	LVL #5	Douglas fir	1.69	9.45	0.08	21	23
6	LVL #5	Douglas fir	3.54	9.45	0.33	46	47
9	LVL #7	Eucalyptus	1.61	9.41	0.28	18	19
10	LVL #8	Southern pine	1.77	9.41	0.26	18	22
12	LVL #11	Yellow poplar	1.73	9.06	0.46	14	19
13	PSL #12	Douglas fir	6.93	9.88	0.26	101	101

¹ Assumed a nominal char rate of 1.5 in/hr.

AWC Beam Tests

In 2014, AWC funded a series of SCL bending tests at the Western Fire Center (WFC) [43]. Six fire resistance tests of SCL beams were conducted in accordance with ASTM E119. The beams were exposed on three surfaces (bottom and sides) and loaded in flexure to various percentages of their design load. The test plan was developed to encompass a range of SCL types, beam sizes and load ratios. Several of these products had larger cross-sections that required thinner laminations to be glued together to form larger cross-sections. This gluing was done under controlled conditions using adhesives that meet the elevated temperature performance requirements for glulam and SCL in ASTM D7247 [64], and were bonded under in-plant, controlled conditions.

All beams were loaded to a predetermined load using 2 hydraulic cylinders. Lateral bracing was provided at the ends and at the load points. After the full-scale tests, WFC found that the actual load was slightly greater than the target load for each beam. The ASD stress ratios and calculated structural failure times based on the actual loads reported by WFC are reported in Table 2.7B and compared against measured times in Figure 2-7.

Table 2.7B Measured and Calculated SCL Beam Structural Fire Resistance Times

Test No.	Designation	SCL Width (in.)	SCL Depth (in.)	ASD Stress Ratio	Measured (Structural) t_f (min)	Calculated (Structural) t_f^1 (min)
1	LSL	3.5	9.5	0.84	35	26
3	PSL	5.25	9.5	0.56	66	58
5	PSL	3.5	9.5	1.12	26	23
6	PSL	7.0	9.5	0.28	119	99
7	LVL	3.5	9.5	0.56	33	30
9	LVL	7.0	9.5	1.13	50	49

¹ Assumed a nominal char rate of 1.5 in/hr.

Proprietary Beam Tests

In 1994, the Technical University Braunschweig (TUB) conducted two fire resistance tests of loaded PSL beams [44]. The beam tests were conducted in accordance with DIN 4102-2 [45], a European fire test standard similar to ASTM E119. In each test, two PSL beams spanned 187 inches across the horizontal furnace and were spaced 47” apart. The PSL beams were covered with foam concrete slabs which were positioned and able to deform freely with the beams. Lateral bracing was provided by friction of the slabs. The measured times to structural failure are compared to calculated results in Table 2.7C and in Figure 8.

In 1997, the Southwest Research Institute (SWRI) conducted two fire resistance tests of loaded parallel-strand lumber (PSL) beams in accordance with ASTM E119 [46]. The beams were exposed on three surfaces (bottom and sides), and loaded to full design load using 3 hydraulic cylinders. Lateral bracing was provided at the ends and at the load points. While the fire resistance model in this report significantly underpredicted actual structural fire resistance times, analysis of deflection data recorded during the tests indicate an issue with the loading that resulted in less than full design load at the end of the tests. The initial ASD stress and calculated structural fire

resistance times are reported in Table 2.7C and compared against measured times in Figure 2-7.

Table 2.7C Measured and Calculated SCL Beam Structural Fire Resistance Times

Designation	SCL Width (in.)	SCL Depth (in.)	ASD Stress Ratio	Measured (Structural) t_f (min)	Calculated (Structural) t_f^1 (min)
TUB PSL 1	3.94	3.94	1.0	24	24
TUB PSL 2	4.53	19.21	1.0	44	42
SWRi PSL 1	7.87	16.0	1.0	99	73
SWRi PSL 2	8.86	11.8	1.0	112	73

¹ Assumed a nominal char rate of 1.5 in/hr.

Proprietary Column Tests

In 1994, TUB conducted two fire resistance tests of loaded PSL columns [47]. The column tests were conducted in accordance with DIN 4102-2. The first column was 7.87 inches x 7.87 inches and had an unbraced length of 148 inches. The second column was 7.09 inches x 7.09 inches and had an unbraced length of 118 inches. The columns were loaded concentrically through steel plates at each end. For design purposes, the columns were assumed to be pinned at each end; however, analysis of the results suggest that the bearing moment created by concentrically-loaded wood columns with square-cut ends bearing on rigid steel or concrete plates such as found in a fire test laboratory would result in an effective length, L_e , of approximately $0.7L_u$. For analysis purposes of this report, the effective length was estimated to be $L_e = 0.7L_u$. This shorter effective length was used to estimate ASD stress ratios and calculated structural failure times reported in Table 2.7D and compared against measured times in Figure 8.

In 1997, the National Research Council of Canada (NRC) conducted two fire resistance tests of loaded parallel-strand lumber (PSL) columns [48]. These column tests were conducted in accordance with CAN/ULC S101 [49]. The first column was 9.84 inches x 9.84 inches. The second column was 10.50 inches x 10.50 inches. Both columns had unbraced lengths of 150 inches and the exposed length of the column was 120 inches. The columns were loaded concentrically through steel plates at each end. For design purposes, the columns were initially assumed to be fixed at each end by lightweight steel braces; however, the braces were not stiff enough to prevent the column from rotating at the ends. A separate analysis suggested that the effective length factor for design of these columns would be approximately 0.9 which would result in an effective length of $L_e = 0.9L_u$. The first column fire test had furnace temperatures well above the ASTM E119 curve throughout the entire duration of the test, so results were not reported. The second column test was run with loads calculated for an effective length, L_e , of $0.9L_u$ which resulted in underprediction of the fire resistance time. Based on a review of these and other column tests, it appears that the effective length adjustment previously used with the TUB tests, $L_e = 0.7L_u$, results in the best estimate of fire resistance of the second column test and was used to estimate the ASD stress ratio and calculated structural fire resistance time reported in Table 2.7D and compared to measured times in Figure 8.

Table 2.7D Measured and Calculated SCL Column Structural Fire Resistance Times

Designation	Species	SCL Width (in.)	SCL Depth (in.)	ASD Stress Ratio	Measured (Structural) t_f (min)	Calculated (Structural) t_f^1 (min)
TUB PSL 1	Southern pine	7.87	7.87	0.66	42	41
TUB PSL 2	Southern pine	7.09	7.09	0.75	35	37
NRC PSL 2	Southern pine	10.50	10.50	0.92	59	57

¹ Assumed a nominal char rate of 1.5 in/hr.

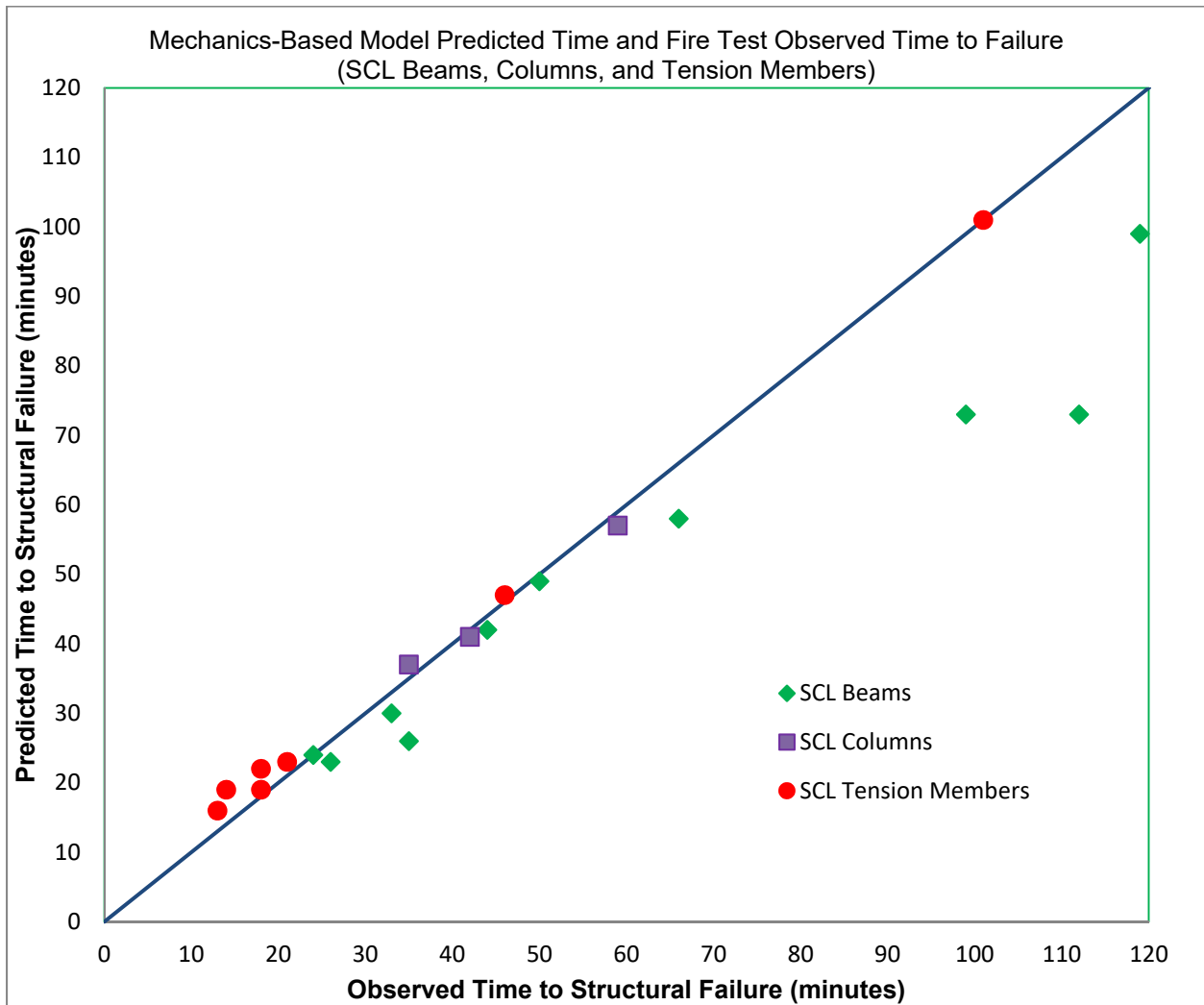

Figure 2-7 Comparison of Predicted to Observed Time to Failure (SCL tests)

2.8 Cross-Laminated Timber

A series of wall and floor tests have been conducted on exposed CLT slab assemblies. Summary descriptions and comparison of these results follows. All CLT in these tests used a polyurethane adhesive available at the time of testing.

NRC CLT Floor and Wall Tests

In 2011, FPInnovations (FPI) in collaboration with the National Research Council of Canada (NRC) conducted a series of 8 full-scale fire resistance tests of CLT floors and walls [50]. All tests followed the ULC S101 time-temperature curve, a fire exposure comparable to the ASTM E119 time-temperature curve. Two of the CLT floors and two of the CLT walls were exposed directly to the flames (unprotected).

Loading of the floors and walls was determined using Canadian standards. For purposes of this analysis, allowable stress design (ASD) values were determined by using the relevant grades from the CLT product standard, PRG-320 [51]. Structural failure time was then calculated using NDS design provisions, developed per Chapter 1 of this report and ASD design values from PRG-320.

NRC Test #3 - Unprotected Floor:

The first unprotected floor test (NRC #3) was a 5-ply CLT slab. Plies were each 1-3/8" thick for a total thickness of 6-7/8 inches. This CLT was constructed using SPF 1950f-1.7E lumber for the face and center laminations and SPF No. 3 grade lumber for the two crossing laminations. This construction matched the grade and layup for CLT Grade E1 from PRG-320.

The dead load of the CLT floor was estimated to be 16 psf. A superimposed load of 245 psf was added, resulting in a total load of 261 psf. Using NDS behavioral equations and standard properties from PRG 320, the allowable resisting moment was calculated as 10,400 ft-lb/ft. To model this specific test result, additional conservatisms built into CLT bending design values were removed (calculations assumed $C_F = 1.0$, $C_{fu} = 1.10$, $C_V = 1.0$, and removal of the 0.85 bending factor) resulting in an adjusted allowable resisting moment of 13,500 ft-lb/ft. Given a span of 186 inches, the induced moment was 7,850 ft-lb/ft (76% of full design load). Failure was recorded at 96 minutes due to burn-through at a lap joint.

NRC Test #4 - Unprotected Wall:

The first unprotected wall test (NRC #4) was a 5-ply CLT slab. Plies were each 1-3/8" thick for a total thickness of 6-7/8 inches. This CLT was constructed using SPF 1950f-1.7E lumber for the face and center laminations and SPF No. 3 grade lumber for the two crossing laminations. This construction matched the grade and layup for CLT Grade E1 from PRG-320.

The dead load of the CLT wall was estimated to be 153 plf. A superimposed load of 22,820 plf was added, resulting in a total load of 22,970 plf. Using standard design properties from PRG 320 and NDS behavioral equations assuming an unbraced wall height of 120 inches and a buckling length coefficient, K_e , of 0.7 (see justification in 2.8) for concentrically-loaded, square-end columns bearing on a rigid foundation, the initial allowable compression capacity was estimated to be 83,200 plf. Failure was recorded at 113 minutes due to structural failure.

NRC Test #7 - Unprotected Floor:

The second unprotected floor test (NRC #7) was a 7-ply CLT slab. Plies were each 1-3/8" thick for a total thickness of 9-5/8 inches. This CLT was constructed using SPF No.1/No.2 grade

lumber for all laminations. For the relevant design properties needed for fire calculations, this construction matched the grade and layout for CLT Grade V2 from PRG-320.

The dead load of the CLT floor was estimated to be 22 psf. A superimposed load of 304 psf was added, resulting in a total load of 326 psf. Using NDS behavioral equations and standard properties from PRG 320, the allowable resisting moment was calculated as 8,275 ft-lb/ft. To model this specific test result, additional conservatisms built into the derivation of CLT design values were removed (calculations assumed $C_f = 1.3$, $C_{fu} = 1.15$, $C_v = 1.0$, and removal of the 0.85 bending factor) resulting in an adjusted allowable resisting moment of 14,600 ft-lb/ft. Given a span of 186 inches, the induced moment was 9,825 ft-lb/ft (119% of full design load). Failure was recorded at 179 minutes due to structural failure.

NRC Test #8 - Unprotected Wall:

The second unprotected wall test (NRC #8) was a 5-ply CLT slab. The plies were each 13/16" thick for a total thickness of 4-1/16 inches. This CLT was constructed using SPF No.1/No.2 grade lumber for all laminations. For the relevant design properties needed for fire calculations, this construction matched the grade for CLT Grade V2 from PRG-320.

The dead load of the CLT wall was estimated to be 92 plf. A superimposed load of 4,933 plf was added, resulting in a total load of 5,025 plf. Using standard design properties from PRG 320 and NDS behavioral equations assuming an unbraced wall height of 120 inches and a buckling length coefficient, $K_e = 0.7$ for concentrically-loaded, square-end columns bearing on a rigid foundation, the initial allowable compression capacity was estimated to be 28,800 plf. Failure was recorded at 57 minutes due to structural failure.

Intertek CLT Wall Test

In May 2012, Intertek conducted a full-scale fire resistance test of a CLT wall [52] using a 5-ply CLT slab. Plies were each 1-3/8" thick for a total thickness of 4-1/16 inches. This CLT was constructed using SPF 1950f-1.7E lumber for the face and center laminations and SPF No. 3 grade lumber for the crossing laminations. This construction matched the grade and layout for CLT Grade E1 from PRG-320. All tests followed the CAN/ULC S101 time-temperature curve. Structural fire resistance was then calculated using provisions in Chapter 1 with appropriate ASD design values from PRG-320. The combined dead load and superimposed load of resulted in a total load of 20,250 plf. Using standard design properties from PRG 320 and NDS behavioral equations assuming an unbraced wall height of 120 inches and a buckling length coefficient, $K_e = 0.7$ for concentrically-loaded, square-end columns bearing on a rigid foundation, the initial allowable compression capacity was estimated to be 41,900 plf. Failure was recorded at 32 minutes due to structural failure.

Results of Analysis

Adjustments to the general design provisions derived in Chapter 1 were required to calculate the structural failure times of tested CLT floor and wall assemblies. First, the nominal char rate of the CLT was found to be approximately 1.5 inches/hr in small-scale tests; however, during full-scale tests, lamination falloff was observed. Working backwards from thermocouple data, lamination falloff was noted to occur at a time approximately related to the approach of the char front to the glueline. Calculation of the char depth, a_{char} , was adjusted to account for the lamination falloff as follows:

$$a_{char} = 1.2 \left[n_{lam} \cdot h_{lam} + \beta_n \left(t - (n_{lam} \cdot t_{gi}) \right)^{0.813} \right]$$

where:

- β_n = nominal char rate (in./hr.), linear char rate based on 1-hour exposure
- t = exposure time (hrs.)

and

$$t_{gi} = \left(\frac{h_{lam}}{\beta_n} \right)^{1.23}$$

- t_{gi} = time to reach glued interface (hr.)
- h_{lam} = lamination thickness (in.)

and

$$n_{lam} = \frac{t}{t_{gi}}$$

- n_{lam} = number of laminations charred (rounded down to lowest integer)

As previously mentioned, a second adjustment was related to conservative assumptions made when assigning CLT bending design values. When design values were assigned for the various grades of CLT, bending stresses were based on reference design values for lumber, not on adjusted design values. As a result, bending design values for CLT E-grades using E-rated laminations were not increased by the flat-use factor, C_{fu} , provided in the NDS. Similarly, design values for CLT V-grades using visually-graded laminations were not increased by the size factor, C_F , nor C_{fu} . In addition, a factor of 0.85 was taken on bending stresses. While significant in overall magnitude, the effect of these combined conservative factors typically has little impact on structural design of floors because spans tend to be limited by deflection and vibration. However, for fire design, these conservative factors can result in significant underpredictions of structural failure times when exposed to fire. For model verification purposes using these CLT fire test results, these conservatisms were removed so that actual fire resistance times could be compared with the fire resistance prediction times. The adjustments, for the purpose of verifying this model should not be construed as a recommendation to deviate from standard design values and assumptions.

The third adjustment was related to shear stiffness modeling. Initial calculations attempted to estimate the change in both the effective bending stiffness, EI_{eff} , and the effective shear stiffness, GA_{eff} . After reviewing the sensitivity of these calculations, it was found that tracking changes in GA_{eff} rather than using the relative EI_{eff} change for both EI_{eff} and GA_{eff} generally resulted in less than 1% difference in the final results. For that reason, it is recommended that changes to GA_{eff} due to charring be rolled into the changes in EI_{eff} , greatly simplifying the calculations and avoiding the need for development of additional adjustments to the procedures in Chapter 1.

A fourth adjustment was related to estimating the effective length of the wall height when designing the wall as a column. In these tests, the strong axis laminations were loaded parallel to grain and bearing was directly on a rigid base. As a result, the initial loading calculations were assumed an effective length of $L_e = 0.7L_u$ as discussed previously in Section 2.7 SCL column tests. As with bending design value adjustments, use of a reduced effective length was for model verification purposes in order to represent actual laboratory conditions but should not be construed as a recommendation to deviate from standard design assumptions.

Measured and calculated fire resistance times for each unprotected CLT test are provided in Table 2.8 and Figure 2-8. The first exposed floor test was terminated early, at about 96 minutes, due to burn-through of the CLT at one of the lap joints. While burn-through would technically be

a failure in an E119 test, it did not result in a structural failure and could have been easily avoided by covering joints on the unexposed side with a floor covering; therefore, the observed failure time was not included in the final comparison of predicted structural failure. For the remaining tests, calculated fire resistance times predicted actual observed fire resistance times very well (see Table 2.8).

Table 2.8 Measured and Calculated CLT Structural Fire Resistance Times

Designation	Species	CLT Application	CLT Thickness (in)	ASD Stress Ratio	Measured (Structural) t_f (min)	Calculated (Structural) t_f^1 (min)
NRC #3	Black Spruce	Floor	6.875	0.76	- ²	113
NRC #4	Black Spruce	Wall	6.875	0.28	113	109
NRC #7	Black Spruce	Floor	9.625	1.19	179	177
NRC #8	Black Spruce	Wall	4.0625	0.17	57	59
Intertek Test	Black Spruce	Wall	4.125	0.48	32	29

¹ Assumed a nominal char rate of 1.5 in/hr.

² Test halted at 96 minutes due to burn-through at unbacked lap joint.

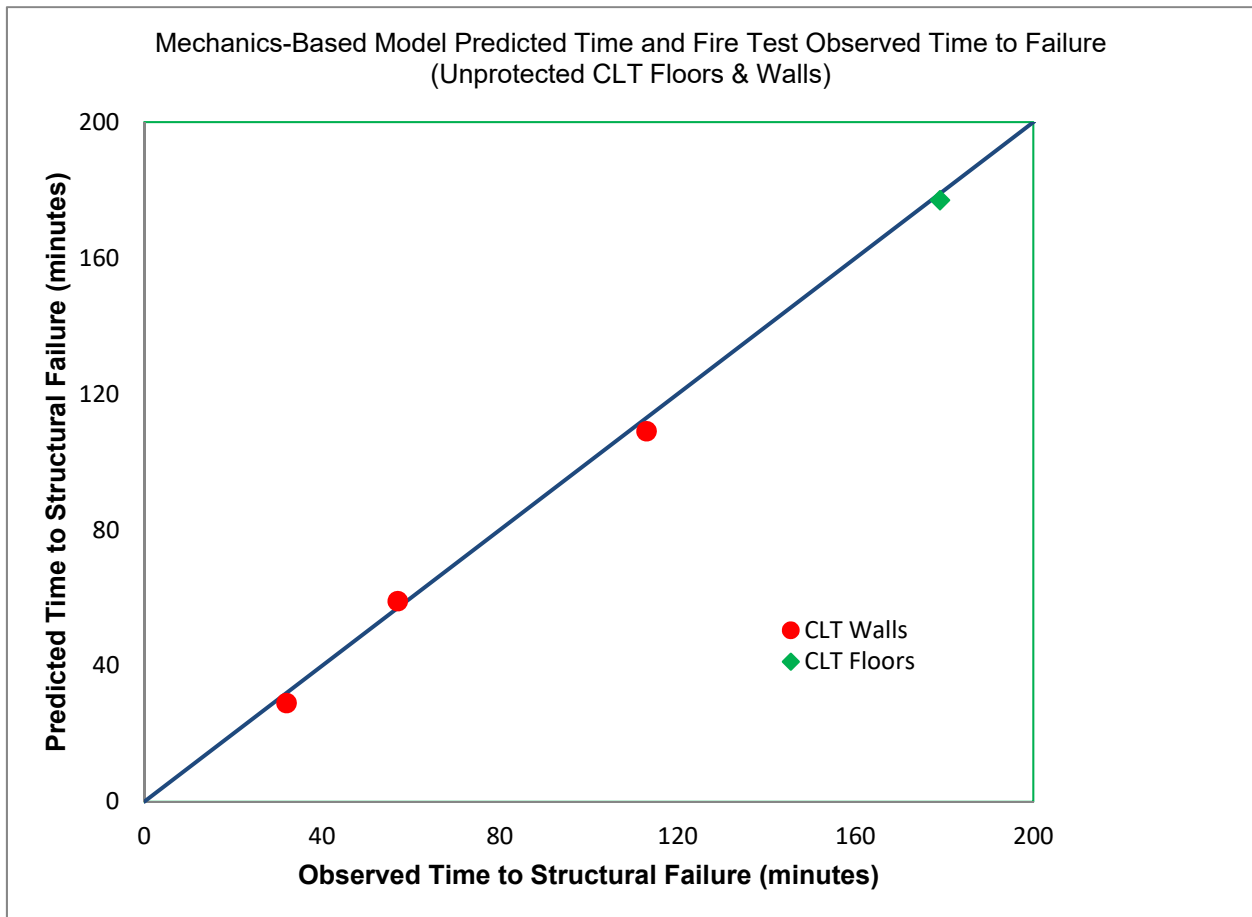

Figure 2-8 Comparison of Predicted to Observed Time to Failure (CLT tests)

2.9 Summary

As can be seen in Figures 2-3 through 2-8, the mechanics-based method which uses a standard nominal char rate, $\beta_n=1.5$ in/hr, for all species, a non-linear char rate adjustment, a constant char acceleration factor of 1.2, and a standard variability adjustment in the design to ultimate adjustment factor predicts average resistance times for beams, columns, decks, and light-frame sawn wood members that closely track actual fire resistance times for tested members. While further refinements of this method are possible, these comparisons suggest that standardized adjustments to design stresses, a standardized accelerated char rate, and the use of *NDS* behavioral equations adequately provide a sound methodology for fire design of exposed wood members.

Part III: Protection of Structural Members and Connections

3.1 General

Protective materials are often used to enhance the fire resistance of wood structural members and connections. Where protective materials are used, various empirical models based on ASTM E119 fire tests have been developed to quantify the benefit of these protective materials. The procedures discussed in this section provide the background for and validation of empirical design procedures to quantify the added fire resistance time of specific protection materials.

3.2 Background

In North America, the original methodology for calculating fire resistance ratings of assemblies using the Component Additive Method (CAM) was developed in the early 1960's by the Fire Test Board of the National Research Council of Canada (NRC) and adopted into U.S. building codes in the 1970's [53]. The methodology resulted from detailed review of 135 fire test reports on wood stud walls and 73 fire test reports on wood-joint floor assemblies, applying the "Ten Rules of Fire Resistance Rating" by Tibor Harmathy, an eminent fire researcher at NRC (see Appendix C). Harmathy's "Ten Rules" provided a method for combining the individual contributions of various materials and layers to obtain the fire resistance rating of an assembly. Fire tests were used to validate the methodology and to develop time values that were assigned to various materials for contribution to the overall fire resistance ratings of tested assemblies. These tests included both loadbearing and non-loadbearing assemblies protected with wood, gypsum wallboard, and other membranes. Fire resistance ratings ranged from 20 to 90 minutes.

The Fire Test Board evaluated the contribution of each element in an assembly and developed a methodology that allowed the fire resistance rating to be calculated as the sum of the contributions from:

1. fire resistance contributed by the exposed membrane,
2. fire resistance of framing members
3. fire resistance contributed by other materials such as cavity insulation, in some cases.

Wall and Ceiling Coverings

The times assigned to protective wall and ceiling coverings were based on the ability of these membranes to remain in place when subjected to the ASTM E 119 fire resistance test (see Table 3.2a). Based on historical construction details, the protective membranes were attached with fasteners spaced not more than 7 inches on center and a minimum penetration into the wood framing of 1 inch for floor/ceiling assemblies and 1.5 inches for wall assemblies. The "assigned time" used in CAM should not be confused with the "finish rating" of a membrane. A "finish rating" is the time it takes for the temperature to rise 250°F on the unexposed surface of a material when the material is exposed to a standard ASTM E 119 Time-Temperature curve. In developing CAM, it was determined that the primary function of the membrane on the unexposed side of a wall or floor/ceiling assembly was to brace the members, hold any insulation in place, and slow the transmission of heat through the assembly.

Description of Finish	Time, min.
3/8-inch Douglas fir plywood, phenolic bonded	5
1/2-inch Douglas fir plywood, phenolic bonded	10
5/8-inch Douglas fir plywood, phenolic bonded	15
3/8-inch gypsum board	10
1/2-inch gypsum board	15
5/8-inch gypsum board	20
1/2-inch Type X gypsum board	25
5/8-inch Type X gypsum board	40
Double 3/8-inch gypsum board	25
1/2 + 3/8-inch gypsum board,	35
Double 1/2-inch gypsum board	40

Notes:

1. On walls, gypsum board shall be installed with the long dimension parallel to framing members with all joints finished. However, 5/8-inch Type X gypsum wallboard may be installed horizontally with the horizontal joints unsupported.
2. On floor/ceiling or roof/ceiling assemblies, gypsum board shall be installed with the long dimension perpendicular to framing members and shall have all joints finished.
3. Recommended fastener schedule:
Wall Assemblies – Type S or W screws with a minimum 1.5-inch penetration into the wood member at 7 inches o.c.
Ceiling Assemblies – Type S or W screws with a minimum 1-inch penetration into the wood member at 7 inches o.c.

Wood Framing Members

Fire resistance times assigned to wood studs and wood joists were based on the ability of framing members to provide structural support when subjected to the ASTM E 119 fire resistance test without benefit of a protective membrane (see Table 3.2b). These times were derived, in part, from the result of full-scale fire tests of unprotected wood stud walls and wood joist floor assembly tests where structural elements were loaded to full design capacity.

Description of Framing Component	Time, min.
Wood studs, 16 inches o.c.	20
Wood joists, 16 inches o.c.	10

Insulation

For wall assemblies, additional fire resistance was recognized when specific insulation materials, such as high-density mineral wool insulation (MWI) or fiber glass insulation (FGI) batts, were used. The time assigned to each type of insulation was based on the increased fire resistance relative to assemblies tested without insulation (see Table 3.2c).

Table 3.2c Time Assigned to Additional Protection

Description of Additional Protection	Time, min.
Add to the fire resistance rating of wood stud walls if the spaces between the studs are filled with rockwool or slag mineral wool batts weighing not less than 1/4 lb./sq. ft. of wall surface.	15
Add to the fire resistance rating of non-loadbearing wood stud walls if the spaces between the studs are filled with glass fiber batts weighing not less than 1/4 lb./sq. ft. of wall surface.	5

Membrane on Unexposed Side

Since the primary function of the membrane on the unexposed side of a wall is to brace the structural members, hold insulation in place, and prevent the transmission of heat through the assembly, it was deemed reasonable to allow substitution of various exterior cladding materials as the membrane on the unexposed side. Within CAM a listing of acceptable sheathing, building paper, and exterior finish were provided and permitted to be used in any combination (see Table 3.2d) or, alternatively, any membrane or combination of membranes with a total assigned time of at least 15 minutes were permitted.

Table 3.2d Membrane on Exterior Face of Walls

Sheathing	Paper	Exterior Finish
5/8-inch T & G lumber 5/16-inch Exterior grade plywood 1/2-inch gypsum board	Sheathing paper	Lumber siding Wood shingles and shakes 1/4-inch Ext. grade plywood 1/4-inch hardboard Metal siding Stucco on metal lath Masonry veneer
None	None	3/8-inch Ext. grade plywood

Note:

Any combination of sheathing, paper (if required), and exterior finish listed below may be used.

Fire resistance testing of roof/ceiling and floor/ceiling assemblies is typically done with exposure from below the assembly. To comply with CAM, floor/ceiling and roof/ceiling assemblies must have a protective membrane on the exposed side of the assembly. Since the primary function of the membrane on the unexposed side of the roof/ceiling or floor/ceiling assembly is to brace the members, hold any insulation in place, and prevent the transmission of heat through the assembly, the upper membrane must consist of a subfloor or roof deck with minimum finish requirements (see Table 3.2e) or, alternatively, any combination of membranes with a total assigned time of at least 15 minutes were permitted.

Table 3.2e Flooring or Roofing Membrane

Assembly	Structural members	Subfloor or roof deck	Finish flooring or roofing
Floor	Wood	1/2-inch plywood or 11/16-inch T&G softwood lumber	Hardwood or softwood flooring on building paper; or Resilient flooring, parquet floor, felted- synthetic-fiber floor coverings, carpeting, or ceramic tile on 3/8-inch-thick panel-type underlay; or Ceramic tile on 1-1/4-inch mortar bed.
Roof	Wood	1/2-inch plywood or 11/16-inch T&G softwood lumber	Finish roofing material with or without insulation.

3.3 AWC Stud Wall Tests

AWC and its predecessor organizations conducted a series of fire resistance tests of light-frame wood stud wall between 1950 and 1975. During that time, the standard wall configuration was a 10' x 10' wall using 2x4 Select Structural grade Douglas Fir-Larch or 2x4 #1 Dense Grade Southern Pine studs. These grades were chosen to allow results from a single, highly-loaded test to be applied to similar wall assemblies constructed with lower grade studs. The load capacity of these walls was typically limited by bearing of the studs on the wall plates which was unaffected by grade.

In 1982, design values for compression perpendicular-to-grain stress ($F_{c\perp}$) changed as a result of modifications made to ASTM D245 *Standard Practice for Establishing Structural Grades and Related Allowable Properties for Visually Graded Lumber*. These modifications changed the basis for development of compression perpendicular-to-grain, $F_{c\perp}$, design values from $F_{c\perp}$ at proportional limit to $F_{c\perp}$ at 0.04" deformation. Because of this change, designs which had previously been limited by $F_{c\perp}$, such as 2x4 bearing wall assemblies, were limited by other criteria. Recognizing that the fire resistance of an assembly under a given load would not change just because the bearing stress had changed, full design load of 2x4 walls designed using old and new $F_{c\perp}$ design values were calculated and compared. For 2x4 wall studs, design capacity became limited by the calculated buckling load rather than the calculated bearing load. In order to continue the use of 2x4 wall assemblies that were based on pre-1982 $F_{c\perp}$ design values, an adjustment factor was calculated by setting the new design load equal to the old design load and solving for the load ratio, $R=0.78$, based on 2x4 Select Structural grade Douglas Fir-Larch, which was the most conservative adjustment for all species and grades. As a result of this analysis, a load factor was developed for all wood stud wall assemblies tested at the reduced load associated with the pre-1982 $F_{c\perp}$ design values. The load factor limited the maximum load to 78% of the full design load for wall studs based on an effective length/stud depth (L_e/d) ratio of 33 or greater. While the 78% limit allowed a means for continued use of 2x4 wall assemblies tested pre-1982, it was conservative for L_e/d ratios less than 33 and very conservative for typical wall assemblies built with 2x6 or deeper studs. New test data for other L_e/d and load ratios were needed.

From 1999 through 2004, the American Wood Council (AWC) conducted a number of full-scale 2x4 and 2x6 wall tests. These wall tests were unique since they were the first public tests conducted at the higher design loads associated with changes to the 1982 NDS. Results from these assemblies are summarized in Table 3.3a and footnoted assemblies are described in DCA3 [54].

Table 3.3a Summary of 1999-2004 Wall Fire Resistance Tests for Different Constructions

ID	Studs	Stud Spacing (in. o.c.)	Cavity Insulation	Exposed Side			Unexposed Side			Fire Resistance (minutes)
				Sheathing Type	Fastener		Sheathing Type	Fastener		
					Type & Size	Spacing (in. o.c.)		Type & Size	Spacing (in. o.c.)	
WP-1229 (07-22-99)	2x6	16	5.5" MWI	5/8" Type X GWB [H]	2-1/4" Type S screws	7	5/8" Type X GWB [H]	2-1/4" Type S screws	7	79
WP-1231 ¹ (09-14-99)	2x6	16	5.5" MWI	5/8" Type X GWB [H]	2-1/4" Type S screws	12	5/8" Type X GWB [H]	2-1/4" Type S screws	12	70
WP-1232 ¹ (09-16-99)	2x6	16	None	5/8" Type X GWB [H]	2-1/4" Type S screws	7	5/8" Type X GWB [H]	2-1/4" Type S screws	7	64
WP-1345 (08-20-03)	2x6	16	R-19 FGI	5/8" Type X GWB [H]	2-1/4" Type S screws	12	5/8" Type X GWB [H]	2-1/4" Type S screws	12	58
WP-1346 ¹ (08-22-03)	2x6	16	R-19 FGI	5/8" Type X GWB [V]	2-1/4" Type S screws	12	5/8" Type X GWB [V]	2-1/4" Type S screws	12	61
WP-1242 (02-23-00)	2x4	16	3.5" MWI	5/8" Type X GWB [H]	2-1/4" Type S screws	7	5/8" Type X GWB [H]	2-1/4" Type S screws	7	71
WP-1248 ¹ (03-29-00)	2x4	16	3.5" MWI	5/8" Type X GWB [H]	2-1/4" Type S screws	12	5/8" Type X GWB [H]	2-1/4" Type S screws	12	65
WP-1249 (03-31-00)	2x4	16	None	5/8" Type X GWB [H]	2-1/4" Type S screws	7	5/8" Type X GWB [H]	2-1/4" Type S screws	7	58
WP-1260 (10-20-00)	2x4	16	None	5/8" Type X GWB [V]	2-1/4" Type S screws	7	5/8" Type X GWB [V]	2-1/4" Type S screws	7	56
WP-1407 (08-11-04)	2x4	16	R-13 FGI	5/8" Type X GWB [V]	2-1/4" Type S screws	7	5/8" Type X GWB [V]	2-1/4" Type S screws	7	56 ²
WP-1259 (10-18-00)	2x6	24	None	5/8" Type X GWB [H] 5/8" Type X GWB [H]	2-1/4" Type S screws 2-1/4" Type S screws	24 8	5/8" Type X GWB [H] 5/8" Type X GWB [H]	2-1/4" Type S screws 2-1/4" Type S screws	24 8	104
WP-1262 ¹ (11-03-00)	2x6	24	5.5" MWI	5/8" Type X GWB [H] 5/8" Type X GWB [H]	2-1/4" Type S screws 2-1/4" Type S screws	24 8	5/8" Type X GWB [H] 5/8" Type X GWB [H]	2-1/4" Type S screws 2-1/4" Type S screws	24 8	123
WP-1244 ¹ (02-25-00)	2x6	16	5.5" MWI	5/8" Type X GWB [H]	2-1/4" Type S screws	12	7/16" OSB	6d common nails	6/12	60+
WP-1408 ¹ (08-13-04)	2x6	16	R-19 FGI	5/8" Type X GWB [V]	2-1/4" Type S screws	7	3/8" OSB	6d common nails	6/12	60+
WP-1261 ¹ (11-01-00)	2x4	16	3.5" MWI	5/8" Type X GWB [H]	2-1/4" Type S screws	12	3/8" OSB	6d common nails	6/12	60+

¹ Wall assembly described in DCA 3: *Fire Resistance-Rated Wood-Frame Wall and Floor/Ceiling Assemblies*.

² Improper edge nailing (nails too close to the edge of the stud) may have adversely affected this assembly.

Effects of Lumber Size, Fastener Spacing, and Insulation

Several of the AWC tested wall assemblies varied only by a single construction variable, which permitted a relative comparison between contributions from each variable. By combining like tests and comparing the differences in the fire resistance times, a table of relative times was developed that provided an estimate of the impact of each variable as shown in Table 3.3b.

Table 3.3b Comparison of 1999-2004 Wall Fire Resistance Test Results

Variable	Variable Change	Impact of Change
Lumber Size and Load Ratio ¹	2x4 @ 1.0F _c ' → 2x6 @ 0.6 F _c '	+6 minutes
Gypsum Wallboard screw spacing	7" o.c. → 12" o.c.	-8 minutes
Insulation	None → Mineral Wool Insulation	+15 minutes

¹ Wall assemblies constructed with 2x6 studs were limited by compression perpendicular-to-grain, F_{c⊥}, of 625 psi which resulted in an induced load of approximately 60% of the full design load based on adjusted compression parallel-to-grain, F_c' only.

Contribution of Studs Without Insulation

To estimate the contribution of lumber studs, the design procedures for exposed wood members in Section 4.1 were used. All fire tested walls were nominal 10 feet x 10 feet, with unbraced stud lengths, L_u, of 115.5 inches. The walls were initially loaded concentrically through concrete-encased steel I-beams.

Charring of a stud on three sides creates an eccentricity about the major axis of the stud due to a shift in the centerline of the remaining section relative to the load applied at the top or bottom of the wall through I-beams. This eccentricity results in a moment in the stud which increases as the fire progresses, ultimately resulting in structural failure of the studs. Design of studs for this eccentricity is addressed with the column eccentricity provisions in NDS Section 15.4.1. For design purposes, walls were assumed to be pinned at each end; however, analysis of the results suggested that the bearing moment created by concentrically-loaded wood studs with square-cut bearing on wood plates loaded through rigid beams, such as found in a fire test frame, resulted in an effective length, L_e , of approximately $0.7L_u$. For analysis purposes in this report, the effective length was estimated to be $L_e = 0.7L_u$. The shorter effective length was used to estimate the adjusted f_c/F_c' stress ratios and calculated fire resistance times reported in Table 3.3c.

Table 3.3c Calculated Wall Stud Fire Resistance Times

Stud Size	Bearing Stress Ratio ¹ (f_c / F_c')	Axial Compression Stress Ratio (f_c / F_c')		Calculated Fire Resistance Time (min)
		$K_e=1.0$ ²	$K_e=0.7$ ³	
2x4	61%	78%	42%	12
	78%	100%	54%	10
2x6	100%	61%	42%	14

¹ The Bearing Stress Ratio limits the allowable load on 2x6 studs as a result of the calculated compression perpendicular-to-grain stress, $F_{c\perp}'$.

² The Axial Compression Stress Ratio for $K_e=1.0$ limits the allowable load on 2x4 studs as a result of the calculated compression parallel-to-grain stress, F_c' , assuming concentric loading and pinned-end reactions at each end of studs.

³ The Axial Compression Stress Ratio for $K_e=0.7$ is the basis of the calculated fire resistance times and is based on the calculated compression parallel-to-grain stress, F_c' , assuming concentric loading and square-end bearing reactions at each end of studs.

Contribution of Insulation

Increases in calculated fire resistance times for studs protected on the sides by insulation varies slightly by stud depth and load ratio. As a result, the fire resistance time of studs with insulation was evaluated assuming normal charring at the exposed edge of a stud and delayed charring at the protected sides of the stud. Failure was assumed to occur when the reduced cross-section of the stud was no longer able to support the applied load. Mineral wool insulation with a nominal weight of 2.5 pounds per cubic foot was estimated to delay initiation of charring by 19 minutes on each protected surface. Fiberglass insulation with a minimum thermal rating of R-13 was estimated to delay initiation of charring by 3 minutes on each protected surface. Given these estimated times for protection provided by the insulation, fire resistance times were computed for loaded studs protected on the sides of the studs with mineral wool insulation or fiberglass insulation, and are provided in Table 3.3d. Because studs protected with insulation on the sides is a common configuration, the effective contribution of the insulation can be separated from the time assigned to the stud to develop times assigned to the insulation as shown in the last column of Table 3.3d. Note that the times assigned for insulation in Table 3.3d are less than the 19-minute and 3-minute times assigned to the insulation because only the sides of the studs are protected by the insulation, while the facing edge is exposed to the fire.

Table 3.3d Time Assigned to Wood Studs Protected with Insulation

Description of Framing Component	Axial Compression Ratio		Time Assigned to Insulated Stud min.	Time Assigned to Insulation Only min.
	(K _e = 1.0)	(K _e = 0.7)		
Fire resistance rating of wood stud walls where spaces between studs are filled with mineral wool insulation weighing not less than 2.5 pounds per cubic foot.				
2x4 studs	1.00	0.54	23	13
	0.78	0.42	25	14
2x6 studs	0.61	0.42	30	16
Fire resistance rating of wood stud walls where spaces between studs are filled with minimum fiberglass insulation (R-13).				
2x4 studs	1.00	0.54	12	2
	0.78	0.42	14	2
2x6 studs	0.61	0.42	16	2

Contribution of Gypsum Wallboard

The results from the relative comparisons provided in Table 3.3b and the calculated fire resistance of studs provided in Table 3.3c and Table 3.3d were evaluated to assign times to gypsum wallboard as shown in Table 3.3e.

Table 3.3e Time Assigned to Gypsum Wallboard Membrane

Description of Finish	Stud Spacing, in.	Time, min.
5/8-inch Type X gypsum wallboard 2.25" drywall screws @ 7" o.c.	16	48
5/8-inch Type X gypsum wallboard 2.25" drywall screws @ 8" o.c.	24	44
5/8-inch Type X gypsum wallboard 2.25" drywall screws @ 12" o.c.	16	40

Calculated Assembly Resistance

To verify the fire resistance time assigned to each component, the assemblies reported in Table 3.3a were compared against the estimates using the sum of the assigned times in Tables 3.3c through 3.3e. The results of this analysis are provided in Table 3.3f and Figure 3-1.

Table 3.3f Calculated Stud Wall Fire Resistance Times

ID	Studs	Stud Spacing (inches o.c.)	Cavity Insulation	Exposed Side			Unexposed Side			Lumber Stud		GWB Time (min.)	Insulation Time (min.)	Calc'd Time (min.)	Measured Time (min.)	Time Diff. (min.)
				Sheathing Type	Fastener		Sheathing Type	Fastener		Design Stress Ratio	Time (min.)					
					Type & Size	Spacing (in. o.c.)		Type & Size	Spacing (in. o.c.)							
WP-1229 (07-22-99)	2x6	16	5.5" MWI	5/8" Type X GWB [H]	2-1/4" Type S screws	7	5/8" Type X GWB [H]	2-1/4" Type S screws	7	0.60	14	48	16	78	79	-1
WP-1231 (09-14-99)	2x6	16	5.5" MWI	5/8" Type X GWB [H]	2-1/4" Type S screws	12	5/8" Type X GWB [H]	2-1/4" Type S screws	12	0.60	14	40	16	70	70	0
WP-1232 (09-16-99)	2x6	16	None	5/8" Type X GWB [H]	2-1/4" Type S screws	7	5/8" Type X GWB [H]	2-1/4" Type S screws	7	0.60	14	48	0	62	64	-2
WP-1345 (08-20-03)	2x6	16	R-19 FGI	5/8" Type X GWB [H]	2-1/4" Type S screws	12	5/8" Type X GWB [H]	2-1/4" Type S screws	12	0.60	14	40	2	56	58	-2
WP-1346 (08-22-03)	2x6	16	R-19 FGI	5/8" Type X GWB [V]	2-1/4" Type S screws	12	5/8" Type X GWB [V]	2-1/4" Type S screws	12	0.60	14	40	2	56	61	-5
WP-1242 (02-23-00)	2x4	16	3.5" MWI	5/8" Type X GWB [H]	2-1/4" Type S screws	7	5/8" Type X GWB [H]	2-1/4" Type S screws	7	1.00	10	48	13	71	71	0
WP-1248 (03-29-00)	2x4	16	3.5" MWI	5/8" Type X GWB [H]	2-1/4" Type S screws	12	5/8" Type X GWB [H]	2-1/4" Type S screws	12	1.00	10	40	13	63	65	-2
WP-1249 (03-31-00)	2x4	16	None	5/8" Type X GWB [H]	2-1/4" Type S screws	7	5/8" Type X GWB [H]	2-1/4" Type S screws	7	1.00	10	48	0	58	58	0
WP-1260 (10-20-00)	2x4	16	None	5/8" Type X GWB [V]	2-1/4" Type S screws	7	5/8" Type X GWB [V]	2-1/4" Type S screws	7	1.00	10	48	0	58	56	2
WP-1407 (08-11-04)	2x4	16	R-13 FGI	5/8" Type X GWB [V]	2-1/4" Type S screws	7	5/8" Type X GWB [V]	2-1/4" Type S screws	7	1.00	10	48	2	60	56	4
WP-1259 (10-18-00)	2x6	24	None	5/8" Type X GWB [H]	2-1/4" Type S screws	24	5/8" Type X GWB [H]	2-1/4" Type S screws	24	0.60	14	88	0	102	104	-2
WP-1262 (11-03-00)	2x6	24	5.5" MWI	5/8" Type X GWB [H]	2-1/4" Type S screws	24	5/8" Type X GWB [H]	2-1/4" Type S screws	24	0.60	14	88	16	118	123	-5
				5/8" Type X GWB [H]	2-1/4" Type S screws	8	5/8" Type X GWB [H]	2-1/4" Type S screws	8							

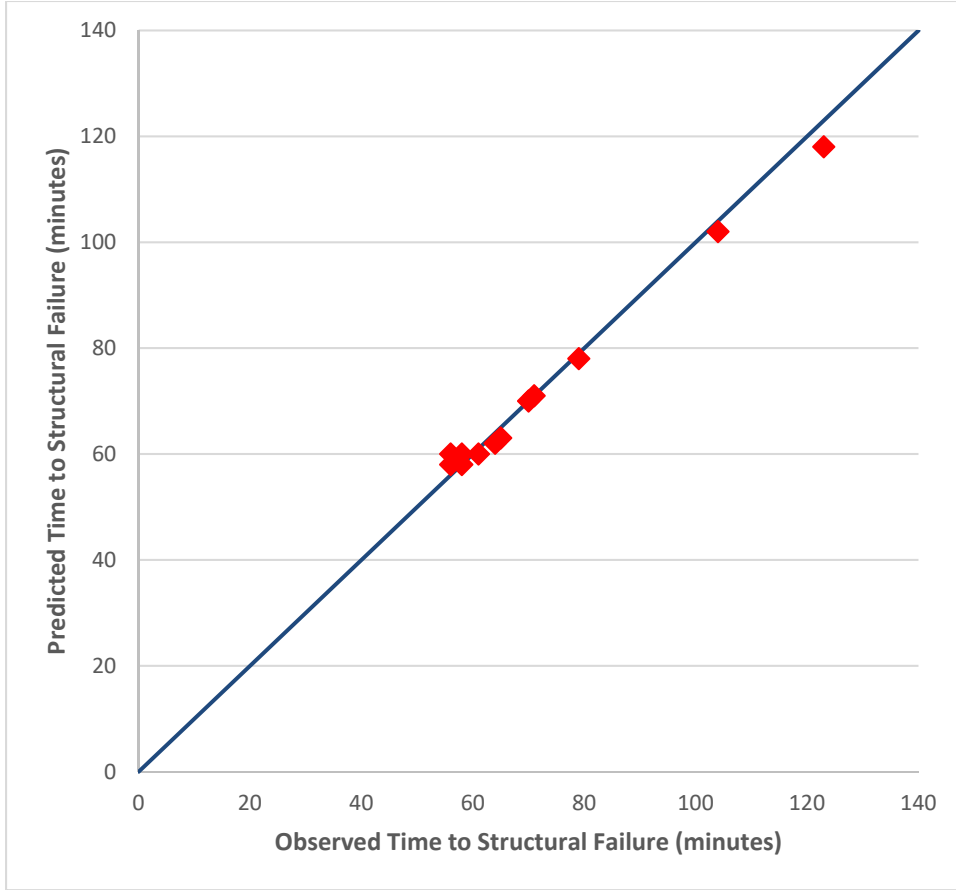

Figure 3-1 Comparison of Predicted to Observed Time to Failure (Stud Wall tests)

As a final comparison of the assigned component fire resistance times, three trial assemblies were evaluated comparing the AWC tests-based estimate with the CAM estimate, and the results are provided in Table 3.3h.

Table 3.3h Comparison of Calculated Wall Stud Fire Resistance Times with CAM Estimates

ID	Studs	Stud Spacing (inches o.c.)	Cavity Insulation	Exposed Side			Unexposed Side			Lumber Stud		GWB ² Time	Insulation ³ Time	Calc'd Time	CAM Time	Time Diff.
				Sheathing Type	Fastener		Sheathing Type	Fastener		Design Stress Ratio	Time ¹					
					Type & Size	Spacing (in. o.c.)		Type & Size	Spacing (in. o.c.)							
CAM-1	2x4	16	None	5/8" Type X GWB [H]	2-1/4" Type S screws	7	5/8" Type X GWB [H]	2-1/4" Type S screws	7	0.78	12	48	0	60	60	0
CAM-2	2x4	16	3.5" MWI	5/8" Type X GWB [V]	2-1/4" Type S screws	7	5/8" Type X GWB [V]	2-1/4" Type S screws	7	0.78	12	48	15	75	75	0
CAM-3	2x4	16	R-13 FGI	5/8" Type X GWB [V]	2-1/4" Type S screws	7	5/8" Type X GWB [V]	2-1/4" Type S screws	7	0.78	12	48	2	62	65	-3

¹ Time assigned in Table 3.3c

² Time assigned in Table 3.3e

³ Time assigned in Table 3.3d

Wall Studs Protected with Plywood Paneling

In 1974, the National Forest Products Association (now AWC) funded a test of an asymmetrical wall assembly at Factory Mutual Research [55]. The wood wall assembly was constructed with Stud grade Engelmann spruce 2x4 studs spaced at 16 inches on center. Wall height was 10 feet and was sheathed on the fire-exposed side with 1/4-inch Luan paneling and on the unexposed side with 1/2-inch regular gypsum wallboard. The wall was loaded with a combined dead plus live load of 1024 pounds per stud.

To estimate the fire resistance contribution of the lumber studs, the design procedures in Section 4.1 were used. The studs were assumed to have unbraced stud lengths, L_u , of 115.5 inches. The walls were loaded concentrically. For analysis purposes in this report, the effective length was estimated to be $L_e = 0.7L_u$. This shorter effective length provided a load ratio of 82% based on NDS design provisions with an estimated fire resistance time of 11 minutes.

To estimate the contribution of the 1/4-inch Luan paneling, the char rate equation in Section 4.1 was used. Assuming a nominal char rate of 1.5 inch/hr, the contribution from the 1/4-inch (0.22-inch thick) Luan paneling was 6 minutes. The total estimated fire resistance time to structural failure was 17 minutes compared with an actual structural fire resistance time of 22 minutes.

3.4 Light-Weight Floor-Ceiling Tests

A number of fire resistance tests of light-frame lumber joist, metal-plate parallel-chord wood truss, and prefabricated wood I-joist floor/ceiling assemblies have been conducted over the last 50 years. Unfortunately, the older reports are hard to source. Table 3.4a summarizes the information contained in the available referenced reports.

Table 3.4a Floor/Ceiling Fire Resistance Test Results

ID	Structural Members	Member Spacing (inches o.c.)	Cavity Insulation	Exposed Side			Unexposed Side Sheathing Type	Test Time (min.)
				Sheathing Type	Fastener			
					Type & Size	Spacing (in. o.c.)		
FM FC-181 (08-31-72)	2x10	16	3.5 FGI	1/2" Type X GWB [R]	1" Type S screws	12	5/8" WSP + 3/8" PBD	60+
UL R1319-65 (11-16-64)	2x10	16	<none>	1/2" Type X GWB [R]	1" Type S screws	12	19/32" WSP + 15/32" WSP	60+
UL R3543-8 (07-08-68)	2x10	16	<none>	1/2" Type X GWB [R]	1" Type S screws	11	5/8" WSP + 1/2" PBD	60+
UL R2717-29 (01-24-64)	2x10	16	<none>	1/2" Type X GWB [R]	1" Type S screws	12	5/8" WSP + 3/8" PBD	60+
UL R3501-29 (03-23-64)	2x10	16	<none>	1/2" Type X GWB [R]	1" Type S screws	12	5/8" WSP + 3/8" PBD	60+
UL R1319-66 (03-23-64)	2x10	16	<none>	1/2" Type X GWB [D]	1-5/8" 5d Nails	6	19/32" WSP + 15/32" WSP	60+
FM FC-77 (11-03-67)	2x10	16	<none>	1/2" Type X GWB [R]	1" Type S screws	12	1-11/32" Fiber Decking	60+
UL R1319-47 (05-08-63)	2-2x10	48	<none>	5/8" Type X GWB [R]	1" Type S screws	12	1-1/8" WSP	60+
UL R3501-5 (07-15-52)	2x10	16	<none>	5/8" Type X GWB [D]	1-7/8" 6d Nails	6	19/32" WSP + 15/32" WSP	60+
FM FC-172 (02-25-72)	2x10	24	<none>	5/8" Type X GWB [D] 5/8" Type X GWB [D]	1-1/4" Type S screws 1-7/8" Type S screws	24 12	1/2" WSP	60+
FM FC-214 (07-06-78)	12" PCT 2x4 chords	24	<none>	1/2" Type X GWB [D] 1/2" Type X GWB [D]	1-1/4" Type S screws 1-7/8" Type S screws	24 12	19/32" WSP	69
FM FC-235 (08-06-76)	12" PCT 2x4 chords	24	<none>	5/8" Type X GWB [D] 8"x20.5" GWB pieces over unbacked joints	1-5/8" Type S screws	12	3/4" WSP	50
FM FC-249 (04-13-77)	12" PCT 2x4 chords	24	<none>	5/8" Type C GWB [R]	1" Type S screws	12	3/4" WSP	58
FM FC-250 (05-10-77)	12" PCT 2x4 chords	24	<none>	<none>	-		3/4" WSP	10
UL R9500-1 (02-02-81)	12" PCT 2x4 chords	24	<none>	5/8" Type C GWB [F]	1" Type S screws	12	23/32" WSP	61
FM FC-426 (1986)	14" PCT 2x4 chords	24	<none>	5/8" Type C GWB [F] 5/8" Type C GWB [F]	1-1/4" Type S screws 1-7/8" Type S screws	24 12	23/32" WSP	112

WHI-651-0311.1 ¹ (02-09-90)	11-1/4" IJ 3/8" web	24	1.5" MWI (2.5 pcf)	5/8" Type C GWB [F]	1-1/8" Type S screws	12	23/32" WSP	60
WHI-694-0159 ¹ (06-19-84)	9-1/4" IJ 7/16" web	24	1.5" MWI (2.5 pcf)	5/8" Type C GWB [R]	1-1/8" Type S screws	12	23/32" WSP	60
UL NC3369 ¹ (09-28-01)	9-1/4" IJ 3/8" web	24	2" MWI (3.5 pcf)	5/8" Type C GWB [R] 1x4 wood setting strip	1-1/8" Type S screws	7	23/32" WSP	65
NGC FC-687 ¹ (02-25-07)	9-1/2" IJ 3/8" web	24	<none>	1/2" Type C GWB [D] 1/2" Type C GWB [D]	1" Type S screws 1-5/8" Type S screws	12 12	23/32" WSP	64
NRC A-4440.1 ¹ (06-24-97)	9-1/2" IJ 3/8" web	24	<none>	1/2" Type X GWB [R] 1/2" Type X GWB [R]	1-1/4" Type S screws 1-5/8" Type S screws	12 12	23/32" WSP	75
NRC A-4219.13.2 ¹ (03-23-98)	9-1/2" IJ 3/8" web	24	FGI	1/2" Type X GWB [R] 1/2" Type X GWB [R]	1-1/4" Type S screws 1-5/8" Type S screws	12 12	23/32" WSP	74
PFS #92-56 ¹ (12-16-92)	9-1/4" IJ 3/8" web	24	3.5" FGI	5/8" Type C GWB [D] 5/8" Type C GWB [R] 5/8" Type C GWB [R]	1-5/8" Type S screws 1" Type S screws 1-5/8" Type S screws	12 8 8	23/32" WSP	122+

¹ Wall assembly described in DCA 3: Fire Resistance-Rated Wood-Frame Wall and Floor/Ceiling Assemblies.

FGI – fiberglass insulation
 GWB – gypsum wallboard
 WSP – wood structural panel
 PBD – particleboard
 PCT – metal plate-connected truss
 IJ – wood I-joist

Contribution of Wood Structural Members

To estimate the fire resistance contribution of wood structural members in these tests, design procedures for exposed wood members in Section 4.1 were used. However, for lumber joists, only summary reports were available. Lumber joists tested prior to 1970 were assumed to have been surfaced in the green condition, so initial dimensions assigned by lumber grading agencies prior to 1970 were used. All lumber joists were nominal 2x10s. Based on test results, it appears that some of the floor joists were not loaded to full design capacity, so a range of fire resistance times were calculated based on three-sided exposure and stress ratios from 50% to 100% of design as shown in Table 3.4b.

For parallel-chord trusses analyzed in this study, the fire resistance time of wood chord members was calculated assuming a four-sided exposure of the bottom chord with full-length members without splice plates as shown in Table 3.4b. All chords were 4x2 members and presumed to be loaded to 100% design load. Where chords have been spliced with light-gage metal splice plates, fire resistance times of 3-6 minutes have been reported [56].

Calculation of the fire resistance of I-joists was more complex since there were different elements, conditions of exposure, protection, and sizes for each test. The calculated fire resistance time for common elements are provided in Table 3.4b. Protection times assigned to mineral wool and fiberglass insulation of 17 and 3 minutes, respectively, were derived using the procedures for studs in Section 3.3; however, increases in calculated fire resistance times from insulation varied relative to the location and amount of protection provided by the insulation to I-joist flanges and webs. As a result, the estimated delay in initiation of charring on each wood surface protected by the insulation material was included in the calculation of fire resistance times of the flange and web element rather than provided as an additional time from the insulation alone.

Table 3.4b Estimated Fire Resistance Times for Wood Structural Members

Description	Dimension	Design Stress Ratio	Predicted Time (minutes)
Lumber Joists			
2x10 (prior to 1970)	1.75" x 9.5"	50 - 100%	19 - 13
2x10 (after 1970)	1.5" x 9.25"	50 - 100%	16 - 11
2x10 - Doubled (prior to 1970)	3.5" x 9.5"	50 - 100%	42 - 29
Truss - Parallel Chord			
2x2 (no splice plates)	1.5" x 1.5"	100%	7
4x2 (no splice plates)	3.5" x 1.5"	100%	10
4x2 (unprotected splice plates)	3.5" x 1.5"	100%	3 - 6 ¹
I-joists - Flanges			
<i>4-sides exposed</i>			
1-1/2 x 1-5/16	1.5" x 1.31"	100%	6
1-1/2 x 1-1/2	1.5" x 1.5"	100%	7
1-3/4 x 1-5/16	1.75" x 1.31"	100%	7
3-1/2 x 1-1/2	3.5" x 1.5"	100%	10
<i>Bottom and sides exposed, top protected with fiberglass insulation</i>			
1-1/2 x 1-5/16	1.5" x 1.31"	100%	7
1-1/2 x 1-1/2	1.5" x 1.5"	100%	8
1-3/4 x 1-5/16	1.75" x 1.31"	100%	8
3-1/2 x 1-1/2	3.5" x 1.5"	100%	11
<i>Bottom and sides exposed, top protected with mineral wool insulation</i>			
1-1/2 x 1-5/16	1.5" x 1.31"	100%	9
1-1/2 x 1-1/2	1.5" x 1.5"	100%	9
1-3/4 x 1-5/16	1.75" x 1.31"	100%	10
3-1/2 x 1-1/2	3.5" x 1.5"	100%	17
<i>Bottom exposed, top and sides protected with fiberglass insulation</i>			
1-1/2 x 1-5/16	1.5" x 1.31"	100%	8
1-1/2 x 1-1/2	1.5" x 1.5"	100%	9
1-3/4 x 1-5/16	1.75" x 1.31"	100%	9
3-1/2 x 1-1/2	3.5" x 1.5"	100%	12
<i>Bottom exposed, top and sides protected with mineral wool insulation</i>			
1-1/2 x 1-5/16	1.5" x 1.31"	100%	19
1-1/2 x 1-1/2	1.5" x 1.5"	100%	20
1-3/4 x 1-5/16	1.75" x 1.31"	100%	19
3-1/2 x 1-1/2	3.5" x 1.5"	100%	20
<i>Top and sides protected with mineral insulation, bottom protected with 3/4" wood strips</i>			
1-1/2 x 1-5/16	1.5" x 1.31"	100%	22
1-1/2 x 1-1/2	1.5" x 1.5"	100%	22
1-3/4 x 1-5/16	1.75" x 1.31"	100%	22
3-1/2 x 1-1/2	3.5" x 1.5"	100%	25
<i>All sides protected with mineral wool insulation</i>			
1-1/2 x 1-5/16	1.5" x 1.31"	100%	23
1-1/2 x 1-1/2	1.5" x 1.5"	100%	24
1-3/4 x 1-5/16	1.75" x 1.31"	100%	24
3-1/2 x 1-1/2	3.5" x 1.5"	100%	27

I-joists - Webs				
<i>Both sides exposed</i>				
	3/8"	0.375"	100%	2
	7/16"	0.4375"	100%	3
<i>Both sides protected with fiberglass insulation</i>				
	3/8"	0.375"	100%	5
	7/16"	0.4375"	100%	6
<i>Both sides protected with mineral wool insulation</i>				
	3/8"	0.375"	100%	21
	7/16"	0.4375"	100%	22

¹ Estimate taken from testing of metal splice plate tests reported in Improving the Fire Endurance of Wood Truss Systems, White & Cramer, Pacific Timber Engineering Conference, Gold Coast Australia, 1993 [56].

Contribution of Gypsum Wallboard

Using the calculated fire resistance of structural members from Table 3.4b, the additional time provided by gypsum wallboard protection could be estimated. While it was apparent in most cases that Type C gypsum wallboard provided additional fire resistance, the actual amount varied. Since the fire performance characteristics of Type C gypsum wallboard vary by manufacturer, fire resistance contributions were conservatively assumed to only provide the same additional resistance time as Type X gypsum wallboard for fire resistance-rating calculations. Also, since test results from the lumber joist assemblies did not provide adequate information for comparison, those test results were not used in the analysis.

Results from truss and I-joist assembly tests provided in Table 3.4a and the calculated fire resistance of the structural members provided in Table 3.4b were compared and added fire resistance times contributed by gypsum wallboard were assigned.

Table 3.4c Time Assigned to Gypsum Wallboard Membrane

Description of Finish	Time, min.
1/2-inch Type X gypsum wallboard – single layer	30
5/8-inch Type X gypsum wallboard – single layer	40
1/2- inch Type X gypsum wallboard – two layers	60
5/8-inch Type X gypsum wallboard – two layers	80
5/8-inch Type X gypsum wallboard – three layers	120

Calculated Assembly Resistance

Results from the calculated fire resistance times for structural members provided in Table 3.4b were combined with times assigned to gypsum wallboard membranes provided in Table 3.4c and compared with assembly test results from Table 3.4a as tabulated in Table 3.4d and shown graphically in Figure 3-2. Fire resistance times for trusses were estimated using the fire resistance time assigned to wood trusses without splice plates (wood failure time) since trusses with chord splices with light-gage metal plates were not available. Fire resistance times for I-joist structural members were estimated using the lesser of the flange fire resistance time or web fire resistance time for each test.

Table 3.4d Calculated Floor/Ceiling Structural Fire Resistance Times

ID	Structural Members	Member Spacing (inches o.c.)	Cavity Insulation	Exposed Side			Unexposed Side Sheathing Type	Member		GWB Time	Insulation Time	Calc'd Time	Measured Time	Time Diff.
				Sheathing Type	Fastener			Design Stress Ratio	Time					
					Type & Size	Spacing (in. o.c.)								
FM FC-181 (08-31-72)	2x10	16	3.5 FGI	1/2" Type X GWB [R]	1" Type S screws	12	5/8" WSP + 3/8" PBD	1.0	11	30	0	41	60+ ³	-
UL R1319-65 (11-16-64)	2x10	16	<none>	1/2" Type X GWB [R]	1" Type S screws	12	19/32" WSP + 15/32" WSP	1.0	13	30	0	43	60+ ³	-
UL R3543-8 (07-08-68)	2x10	16	<none>	1/2" Type X GWB [R]	1" Type S screws	11	5/8" WSP + 1/2" PBD	1.0	13	30	0	43	60+ ³	-
UL R2717-29 (01-24-64)	2x10	16	<none>	1/2" Type X GWB [R]	1" Type S screws	12	5/8" WSP + 3/8" PBD	1.0	13	30	0	43	60+ ³	-
UL R3501-29 (03-23-64)	2x10	16	<none>	1/2" Type X GWB [R]	1" Type S screws	12	5/8" WSP + 3/8" PBD	1.0	13	30	0	43	60+ ³	-
UL R1319-66 (03-23-64)	2x10	16	<none>	1/2" Type X GWB [D]	1-5/8" 5d Nails	6	19/32" WSP + 15/32" WSP	1.0	13	30	0	43	60+ ³	-
FM FC-77 (11-03-67)	2x10	16	<none>	1/2" Type X GWB [R]	1" Type S screws	12	1-11/32" Fiber Decking	1.0	13	30	0	43	60+ ³	-
UL R1319-47 (05-08-63)	Double 2x10	48	<none>	5/8" Type X GWB [R]	1" Type S screws	12	1-1/8" WSP	1.0	29	40	0	69	60+ ³	-
UL R3501-5 (07-15-52)	2x10	16	<none>	5/8" Type X GWB [D]	1-7/8" 6d Nails	6	19/32" WSP + 15/32" WSP	1.0	13	40	0	53	60+ ³	-
FM FC-172 (02-25-72)	2x10	24	<none>	5/8" Type X GWB [D] 5/8" Type X GWB [D]	1-1/4" Type S screws 1-7/8" Type S screws	24 12	1/2" WSP	1.0	11	80	0	91	60+ ³	-
FM FC-214 (07-06-78)	12" PCT 2x4 chords	24	<none>	1/2" Type X GWB [D] 1/2" Type X GWB [D]	1-1/4" Type S screws 1-7/8" Type S screws	24 12	19/32" WSP	1.0	10	60	0	70	69	1
FM FC-235 (08-06-76)	12" PCT 2x4 chords	24	<none>	5/8" Type X GWB [D] 8"x20.5" GWB pieces over unbacked joints	1-5/8" Type S screws	12	3/4" WSP	1.0	10	40	0	50	50	0
FM FC-249 (04-13-77)	12" PCT 2x4 chords	24	<none>	5/8" Type C GWB [R]	1" Type S screws	12	3/4" WSP	1.0	10	40 ¹	0	50	58	-8
FM FC-250 (05-10-77)	12" PCT 2x4 chords	24	<none>	<none>	-	-	3/4" WSP	1.0	10	0	0	10	10	0
UL R9500-1 (02-02-81)	12" PCT 2x4 chords	24	<none>	5/8" Type C GWB [F]	1" Type S screws	12	23/32" WSP	1.0	10	40 ¹	0	50	61	-11
FM FC-426 (1986)	14" PCT 2x4 chords	24	<none>	5/8" Type X GWB [F] 5/8" Type X GWB [F]	1-1/4" Type S screws 1-7/8" Type S screws	24 12	23/32" WSP	1.0	10	80 ¹	0	90	112	-22
WHI-651-0311.1 (02-09-90)	11-1/4" IJ 3/8" web	24	1.5" MWI (2.5 pcf)	5/8" Type C GWB [F]	1-1/8" Type S screws	12	23/32" WSP	1.0	20	40 ¹	0 ²	60	60	0

WHI-694-0159 (06-19-84)	9-1/4" IJ 7/16" web	24	1.5" MWI (2.5 pcf)	5/8" Type C GWB [R]	1-1/8" Type S screws	12	23/32" WSP	1.0	20	40 ¹	0 ²	60	60	0
UL NC3369 (09-28-01)	9-1/4" IJ 3/8" web	24	2" MWI (3.5 pcf)	5/8" Type C GWB [R] 1x4 wood setting strip	1-1/8" Type S screws	7	23/32" WSP	1.0	20	40 ¹	0 ²	60	65	-5
NGC FC-687 (02-25-07)	9-1/2" IJ 3/8" web	24	<none>	1/2" Type C GWB [D] 1/2" Type C GWB [D]	1" Type S screws 1-5/8" Type S screws	12 12	23/32" WSP	1.0	2	60 ¹	0 ²	62	64	-2
NRC A-4440.1 (06-24-97)	9-1/2" IJ 3/8" web	24	<none>	1/2" Type X GWB [R] 1/2" Type X GWB [R]	1-1/4" Type S screws 1-5/8" Type S screws	12 12	23/32" WSP	1.0	2	60	0 ²	62	75	-13
NRC A-4219.13.2 (03-23-98)	9-1/2" IJ 3/8" web	24	FGI	1/2" Type X GWB [R] 1/2" Type X GWB [R]	1-1/4" Type S screws 1-5/8" Type S screws	12 12	23/32" WSP	1.0	5	60	0 ²	65	74	-9
PFS #92-56 (12-16-92)	9-1/4" IJ 3/8" web	24	3.5" FGI	5/8" Type C GWB [D] 5/8" Type C GWB [R] 5/8" Type C GWB [R]	1-5/8" Type S screws 1" Type S screws 1-5/8" Type S screws	12 8 8	23/32" WSP	1.0	5	120 ¹	0 ²	125	122+ ⁴	-

¹ Added fire resistance provided by Type C gypsum wallboard used the same values as Type X gypsum wallboard since the performance improvement over the minimum requirement for Type X varies by manufacturer as a result of proprietary formulations.

² Increases in calculated fire resistance times from the use of insulation varied relative to the location and protection provided to the I-joint flanges and webs. As a result, the contribution was included in the calculation of the fire resistance time of the I-joint taking the shortest estimated time from the I-joint flange and I-joint web rather than provided as an additional time from the insulation alone.

³ Test terminated when 1-hr target test time was reached, so actual structural failure time not known.

⁴ Test terminated due to burn-through of floor sheathing rather than structural failure.

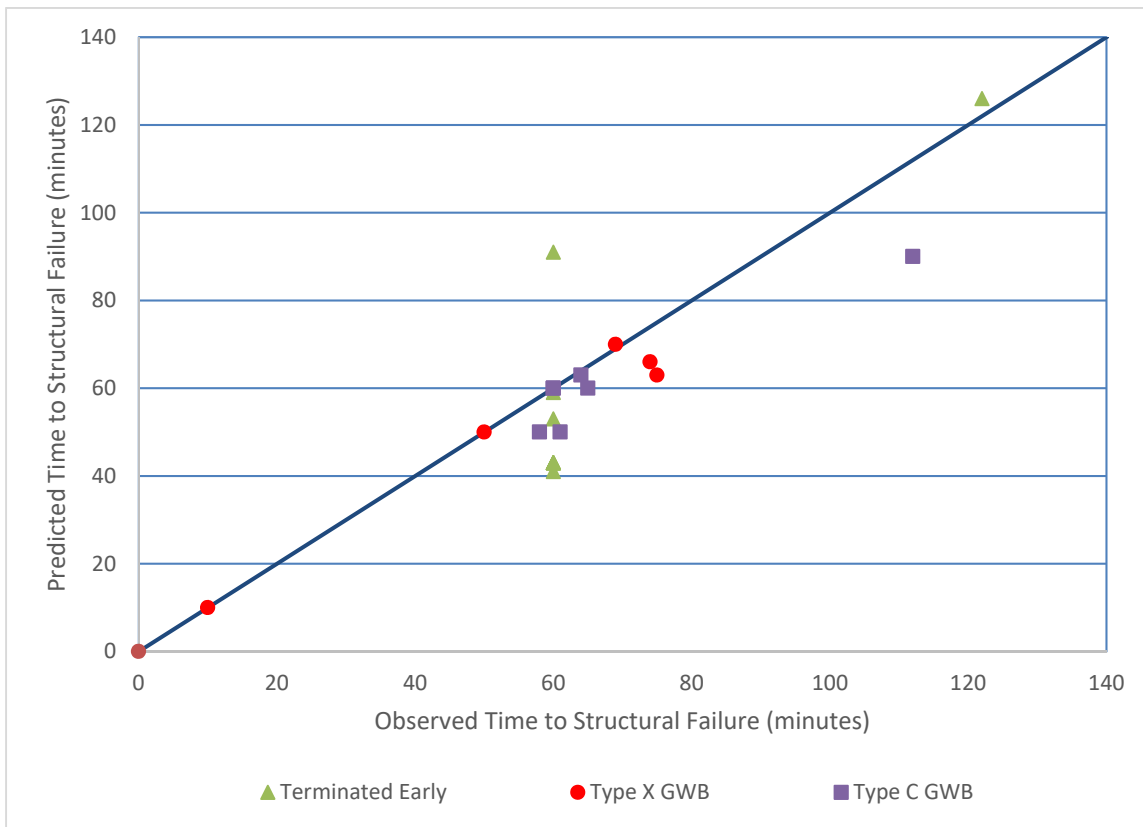

Figure 3-2 Comparison of Predicted to Observed Time to Failure (Floor-Ceiling Assembly tests)

3.5 Rim Board Tests

Fire resistance tests of light-frame wood rim board products, conducted by the USDA Forest Products Laboratory (FPL), were reported in 2003 [57]. Rim boards constructed of oriented strand board (OSB), plywood, Com-Ply, and laminated veneer lumber (LVL) were tested with no applied load. Thermal and char measurements were made on each specimen tested in a small-scale vertical furnace. A number of configurations were also tested in the FPL intermediate-scale horizontal furnace. Single and double rim boards were tested without protection and single rim boards were also tested with gypsum wallboard (GWB) protection.

Rim Boards – Unprotected

For unprotected, single-ply rim boards tested, thermocouples were used to measure unexposed surface temperatures in five locations. Due to the presence of insulating pads on thermocouples, researchers reported that the thermocouples likely reached target temperatures slightly earlier than expected, but no effort was made to adjust the results. Test results are reported in Table 3.5a. In these tests, the time for the char front to reach the unexposed side was estimated to occur when the first thermocouple reading reached 300°C (572°F) which is slightly higher than 288°C (550°F) that has historically been assumed for the char front; however, the difference in time was deemed insignificant. It was also noted that, in most cases, the highest thermocouple reading reached the target char front temperature before flame penetration was observed. Also, the time at which the thermal resistance threshold, defined by an average temperature rise of 139°C (250°F) or a single thermocouple temperature rise of 181°C (325°F), was reached consistent with E119 requirements. The time to reach the thermal threshold averaged 88% (COV=0.02) of the time to reach the char front temperature.

Tests of unprotected, double-ply rim boards were also conducted in the FPL small-scale furnace. Thermocouples were placed between the first and second plies of the rim board and on the unexposed surface of the second ply. Test results are reported in Table 3.5b. Rim board plies were glued together with a phenol-resorcinol adhesive, so the char rate of the composite was assumed to be representative of a single rim board.

Modeling of char depth using the non-linear char equation from Section 4.1 over-predicted the time for the char front to reach the unexposed side, especially for narrower single-ply rim boards. This result was expected for the narrower rim boards since the specimens were relatively thin compared with previous char testing determined from one-dimensional tests of semi-infinite wood slabs [42]. However, while thermocouples between the first and second plies of the double-ply rim board indicated that the char rate of the first ply followed the TR10 nonlinear char equation, the total time for the char front to reach the unexposed side of the second ply was also faster. This result suggests that the charring rate accelerates as the char front approaches burn-through of these one-dimensional wood slabs, likely due to the introduction of increased oxygen and escape of trapped moisture in advance of the char front. To account for this effect in one-dimensional wood elements, an “element char-through” (ECT) model was developed to predict an accelerated char rate as the char front approaches the unexposed surface of both single-ply and double-ply rim boards. In the ECT model, the non-linear char equation is initially used. Depth of the uncharred wood remaining when the char rate of the rim boards accelerated was numerically determined to be approximately 0.6 inches, at which time the char rate increased to approximately 2.1 inches/hour. Estimates using the TR10 non-linear char equation and the one-dimensional ECT model are provided in Table 3.5c, and the goodness-of-fit of the ECT model is shown graphically in Figure 3-3.

Table 3.5a Unprotected Single Rim Boards – Test Results

Test no.	Rim Board Description			Test Times (minutes)		
	Rim Board Type	Layers	Thickness (in.)	Thermal Rise (139/181°C)	Char Front (300°C)	Flame Penetration
1695	OSB-A	1	1.10	29	33	35
1696	OSB-A	1	1.10	28	32	33
1697	OSB-B	1	1.14	31	36	39
1698	OSB-B	1	1.14	30	35	35
1688	OSB-C	1	1.14	32	36	36
1689	OSB-C	1	1.18	33	38	37
1686	Plywood	1	0.94	21	23	25
1687	Plywood	1	0.94	21	23	25
1690	Com-Ply	1	1.10	30	34	37
1691	Com-Ply	1	1.06	30	34	37
1692	LVL	1	1.26	36	40	40
1693	LVL	1	1.22	37	42	41
1694	LVL	1	1.22	35	41	43

Table 3.5b Unprotected Double Rim Boards – Test Results

Test no.	Rim Board Description			Test Times (minutes)		
	Rim Board Type	Layers	Thickness (in.)	Thermal Rise (139/181°C)	Char Front (300°C)	
				Layers 1 & 2	Layer 1	Layers 1 & 2
1702	OSB-A	2	2.20	75	40	81
1704	OSB-B	2	2.28	78	42	83
1700	OSB-C	2	2.28	85	43	88
1699	Plywood	2	1.89	56	31	60
1703	Com-Ply	2	2.09	73	38	80
1701	LVL	2	2.44	87	45	90
1705	LVL	2	2.44	87	46	89

Table 3.5c Modeling Unprotected Rim Boards

Test no.	Rim Board Description			Test Times	Model Estimates (minutes)	
	Rim Board Type	Layers	Thickness (in.)	Char Front (300°C)	Non-linear Char Eqn.	Element Char-Through Model
1695	OSB-A	1	1.10	33	41	33
1696	OSB-A	1	1.10	32	41	33
1697	OSB-B	1	1.14	36	43	34
1698	OSB-B	1	1.14	35	43	34
1688	OSB-C	1	1.14	36	43	34
1689	OSB-C	1	1.18	38	45	36
1686	Plywood	1	0.94	23	34	27
1687	Plywood	1	0.94	23	34	27
1690	Com-Ply	1	1.10	34	41	33
1691	Com-Ply	1	1.06	34	39	31
1692	LVL	1	1.26	40	48	39
1693	LVL	1	1.22	42	47	37
1694	LVL	1	1.22	41	47	37
1702	OSB-A	2	2.20	81	96	82
1704	OSB-B	2	2.28	83	101	86
1700	OSB-C	2	2.28	88	101	86
1699	Plywood	2	1.89	60	80	67
1703	Com-Ply	2	2.09	80	90	76
1701	LVL	2	2.44	90	109	94
1705	LVL	2	2.44	89	109	94

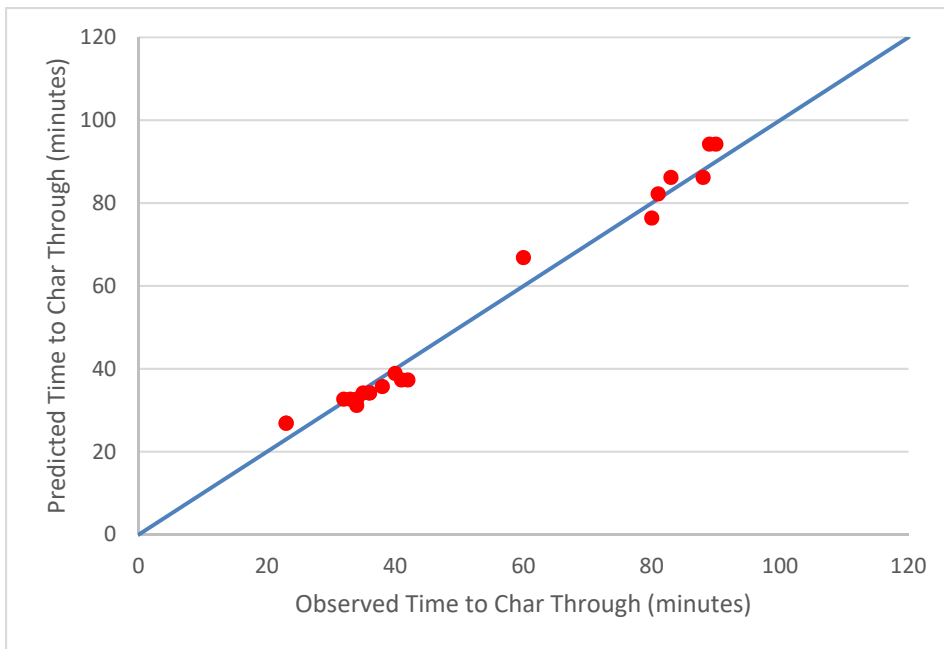

Figure 3-3 Comparison of Predicted to Observed Time to Char Through (Unprotected Rimboard)

Rim Boards –Protected with Gypsum Wallboard

Fire tests of single-ply rim boards protected with gypsum wallboard were also conducted in the small-scale furnace at FPL [57]. Thermocouples were placed on the unexposed face of the rim boards. In some tests, thermocouples were placed between the gypsum wallboard and rim board. Test results are reported in Table 3.5d.

Table 3.5d Protected Rim Boards – Test Results

Test no.	Protection Description			Rim Board Description		Test Times (minutes)			
	Protection Type	Layers	Thickness (in.)	Rim Board Type	Thickness (in.)	Thermal Rise (139°C)		Char Temp (300°C)	
						GWB Only	GWB + Rim Board	GWB Only	GWB + Rim Board
1718	H - Type X GWB (direct)	1	0.50	OSB-C	1.14	14	63	18	65
1736	I - Reg. GWB (direct)	1	0.50	OSB-C	1.14	14	62	18	66
1735	K - Type X GWB (direct)	1	0.63	OSB-C	1.14	27	81	30	89
1706	J - Type X GWB (direct)	1	0.63	OSB-C	1.14	-	71	-	76
1709	J - Type X GWB (air gap)	1	0.63	OSB-C	1.14	-	67	-	70
1719	H - Dbl. Type X GWB (direct)	2	1.00	OSB-C	1.14	47	112	55	125
1710	J - Dbl. Type X GWB (direct)	2	1.25	OSB-C	1.14	-	126	-	134
1707	J - Type X GWB (direct)	1	0.63	Plywood	0.94	-	58	-	65
1708	J - Type X GWB (air gap)	1	0.63	Plywood	0.94	-	60	-	65
1711	J - Dbl. Type X GWB (direct)	2	1.25	Plywood	0.94	-	111	-	117
1720	H - Type X GWB (direct)	1	0.50	OSB-A	1.10	17	55	22	57
1722	J - Type X GWB (direct)	1	0.63	OSB-A	1.10	18	64	22	66
1721	H - Dbl. Type X GWB (direct)	2	1.00	OSB-A	1.10	48	111	58	117

To estimate the added fire resistance provided by gypsum wallboard protection to the total fire resistance time, the ECT model developed for unprotected rim boards was used to estimate the contribution of gypsum wallboard in protected rim board tests. The added fire resistance for each gypsum wallboard configuration was then determined by subtracting unprotected rim board time estimates from protected rim board test times provided in Table 3.5e.

Table 3.5e Contribution of Gypsum Wallboard Protection

Test no.	Protection Description			Rim Board Description		Tested GWB + Rim Board Time	Calc'd Rim Board Time	Added Time GWB	Added Time GWB/layer
	Protection Type	Layers	Thickness (in.)	Rim Board Type	Thickness (in.)				
1718	H - Type X GWB (direct)	1	0.50	OSB-C	1.14	65	34	31	31
1736	I - Reg. GWB (direct)	1	0.50	OSB-C	1.14	66	34	32	32
1735	K - Type X GWB (direct)	1	0.63	OSB-C	1.14	89	34	55	55
1706	J - Type X GWB (direct)	1	0.63	OSB-C	1.14	76	34	42	42
1709	J - Type X GWB (air gap)	1	0.63	OSB-C	1.14	70	34	36	36
1719	H - Dbl. Type X GWB (direct)	2	1.00	OSB-C	1.14	125	34	91	45
1710	J - Dbl. Type X GWB (direct)	2	1.25	OSB-C	1.14	134	34	100	50
1707	J - Type X GWB (direct)	1	0.63	Plywood	0.94	65	27	38	38
1708	J - Type X GWB (air gap)	1	0.63	Plywood	0.94	65	27	38	38
1711	J - Dbl. Type X GWB (direct)	2	1.25	Plywood	0.94	117	27	90	45
1720	H - Type X GWB (direct)	1	0.50	OSB-A	1.10	57	33	24	24
1722	J - Type X GWB (direct)	1	0.63	OSB-A	1.10	66	33	33	33
1721	H - Dbl. Type X GWB (direct)	2	1.00	OSB-A	1.10	117	33	84	42

When comparing the results of Table 3.5d and Table 3.5e, it was apparent that using the time to reach an average thermal rise of 139°C (250°F) or time to reach a char temperature of 300°C (572°F) significantly under-predicted the added contribution of gypsum wallboard. A comparison of the three times and times assigned to the GWB protection in earlier investigations (Sections 3.3 and 3.4) is provided in Table 3.5f.

Table 3.5f Comparison of Gypsum Wallboard Protection Contribution

Protection Type	Layers	Thickness (in.)	Time to Reach 139°C (min.)	Time to Reach 300°C (min.)	Added Time GWB (min.)	Time Assigned to GWB in 3.3 & 3.4 (min.)
H - 1/2" Type X GWB (direct)	1	0.50	14	18	31	30
I - 1/2" Reg. GWB (direct)	1	0.50	14	18	32	15
K - 5/8" Type X GWB (direct)	1	0.63	27	30	55	40
J - 5/8" Type X GWB (direct)	1	0.63	-	-	42	40
J - 5/8" Type X GWB (air gap)	1	0.63	-	-	36	40
H - Dbl. 1/2" Type X GWB (direct)	2	1.00	47	55	91	60
J - Dbl. 5/8" Type X GWB (direct)	2	1.25	-	-	100	80
J - 5/8" Type X GWB (direct)	1	0.63	-	-	38	30
J - 5/8" Type X GWB (air gap)	1	0.63	-	-	38	30
J - Dbl. 5/8" Type X GWB (direct)	2	1.25	-	-	90	80
H - 1/2" Type X GWB (direct)	1	0.50	17	22	24	30
J - 5/8" Type X GWB (direct)	1	0.63	18	22	33	40
H - Dbl. 1/2" Type X GWB (direct)	2	1.00	48	58	84	60
Average Time Assigned per Type						
H - 1/2" Type X GWB (direct)	1	0.50	16	20	28	30
I - 1/2" Reg. GWB (direct)	1	0.50	14	18	32	15
J - 5/8" Type X GWB (direct)	1	0.63	18	22	37	40
K - 5/8" Type X GWB (direct)	1	0.63	27	30	55	40
H - Dbl. 1/2" Type X GWB (direct)	2	1.00	48	57	88	60
J - Dbl. 5/8" Type X GWB (direct)	2	1.25	-	-	100	80
Average Time Assigned per Layer per Type						
H - 1/2" Type X GWB (direct)	1	0.50	20	24	36	30
I - 1/2" Reg. GWB (direct)	1	0.50	14	18	32	15
J - 5/8" Type X GWB (direct)	1	0.63	18	22	40	40
K - 5/8" Type X GWB (direct)	1	0.63	27	30	55	40

The added fire resistance contribution of gypsum wallboard to wood assemblies is more than the delayed temperature rise on the wood surface, as demonstrated in Table 3.5f. In fact, the added fire resistance time estimated from gypsum wallboard protection was approximately 60% longer than the time at which the first thermocouple on the wood surface reached 300°C (572°F). This synergistic behavior is likely due to several factors, including the continued shielding provided by the gypsum wallboard after calcination and the added thermal resistance provided by the water driven into the wood from the gypsum in the form of steam. To evaluate the final model against the small-scale furnace test results, the estimated rim board char-through resistance time determined using the ECT model, and the time assigned to gypsum wallboard in Table 3.5f were added together and compared to the tested char-through time of the assembly in Table 3.5g and Figure 3-4.

Table 3.5g Modeling Protected Rim Boards

Test no.	Protection Description			Rim Board Description		Model Estimates (minutes)			
	Protection Type	Layers	Thickness (in.)	Rim Board Type	Thickness (in.)	Tested GWB + Rim Board Time	Calc'd Rim Board Time	Time Assigned to GWB	Calc'd Rim + GWB Times
1718	H - Type X GWB (direct)	1	0.50	OSB-C	1.14	65	34	30	64
1736	I - Reg. GWB (direct)	1	0.50	OSB-C	1.14	66	34	15	49
1735	K - Type X GWB (direct)	1	0.63	OSB-C	1.14	89	34	40	74
1706	J - Type X GWB (direct)	1	0.63	OSB-C	1.14	76	34	40	74
1709	J - Type X GWB (air gap)	1	0.63	OSB-C	1.14	70	34	40	74
1719	H - Dbl. Type X GWB (direct)	2	1.00	OSB-C	1.14	125	34	60	94
1710	J - Dbl. Type X GWB (direct)	2	1.25	OSB-C	1.14	134	34	80	114
1707	J - Type X GWB (direct)	1	0.63	Plywood	0.94	65	27	40	67
1708	J - Type X GWB (air gap)	1	0.63	Plywood	0.94	65	27	40	67
1711	J - Dbl. Type X GWB (direct)	2	1.25	Plywood	0.94	117	27	80	107
1720	H - Type X GWB (direct)	1	0.50	OSB-A	1.10	57	33	30	63
1722	J - Type X GWB (direct)	1	0.63	OSB-A	1.10	66	33	40	73
1721	H - Dbl. Type X GWB (direct)	2	1.00	OSB-A	1.10	117	33	60	93

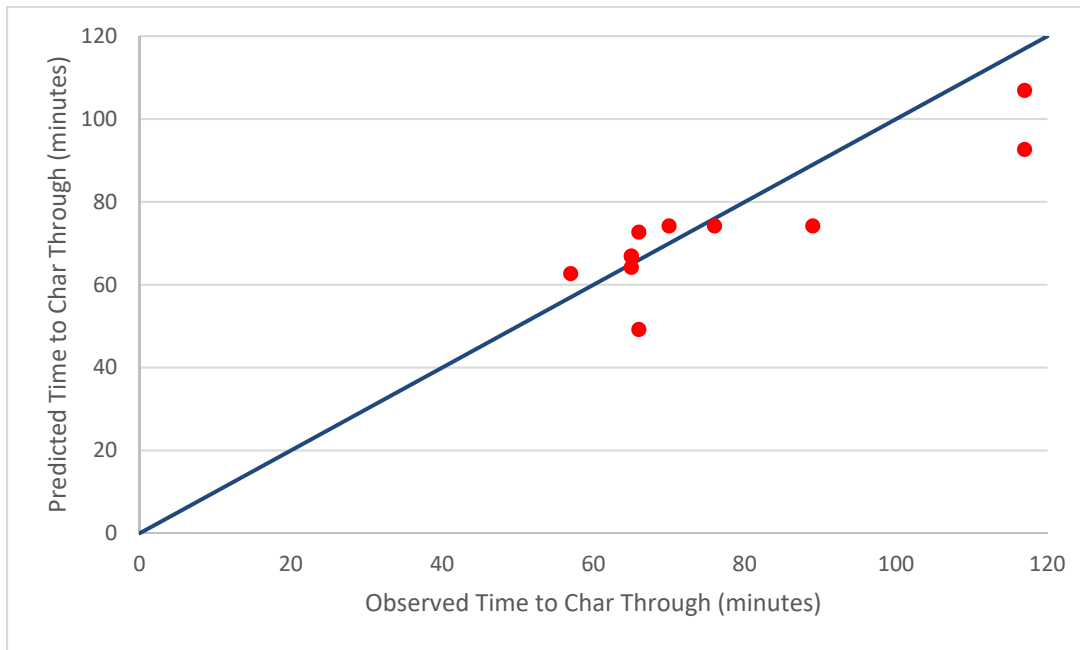

Figure 3-4 Comparison of Predicted to Observed Char-Through Time (GWB-protected Rimboard)

Rim Boards – Intermediate-Scale Tests

Tests of protected and unprotected single-ply rim boards were also investigated in the intermediate-scale horizontal furnace at FPL [57]. Two rim boards were laid edge-to-edge across the top of the horizontal furnace. At the edges where the rim boards abutted, a 6-inch strip of gypsum wallboard was glued across the seam to seal the gap. Thermocouples were placed on the unexposed face of the rim boards. Test results are reported in Table 3.5h.

Table 3.5h Rim Boards – Intermediate-Scale Furnace Test Results

Test no.	Protection Description			Rim Board Description		Test Times (minutes)		
	Protection Type	Layers	Thickness (in.)	Rim Board Type	Thickness (in.)	Thermal Rise (139/181°C)	Char Front (300°C)	Flame penetration
2128	< none >	-	-	OSB-C	1.14	24	29	33
2130	H - Type X GWB (direct)	1	0.50	OSB-C	1.14	73	76	53
2129	K - Type X GWB (direct)	1	0.63	OSB-C	1.14	77	80	46
2131	H - Dbl. Type X GWB (direct)	2	1.00	OSB-C	1.14	116	118	62
2127	< none >	-	-	LVL	1.22	36	40	44

Similar to the small-scale test results, the added fire resistance provided by gypsum wallboard protection to the total fire resistance time was estimated by subtracting the ECT time estimated for bare rim boards from the total time until the char front had reached the backside for protected rim boards. The added fire resistance for each gypsum wallboard configuration was then determined and provided in Table 3.5i.

Table 3.5i Added Contribution of Gypsum Wallboard Protection

Test no.	Protection Description			Rim Board Description		Tested GWB + Rim Board Time	Calc'd Rim Board (RB) Time	Added Time GWB	Added Time GWB/layer
	Protection Type	Layers	Thickness (in.)	Rim Board Type	Thickness (in.)				
2130	H - 1/2" Type X GWB (direct)	1	0.50	OSB-C	1.14	76	34	42	42
2129	K - 5/8" Type X GWB (direct)	1	0.63	OSB-C	1.14	80	34	46	46
2131	H - Dbl. 1/2" Type X GWB (direct)	2	1.00	OSB-C	1.14	118	34	84	42

To evaluate the final model against the intermediate-scale horizontal furnace test results, estimated rim board char-through time determined using the ECT model, and additional time assigned to the gypsum wallboard in Table 3.5f were added together and compared to the tested fire resistance of the assembly in Table 3.5j and Figure 3-5.

Table 3.5j Modeling Protected Rim Boards

Test no.	Protection Description			Rim Board Description		Model Estimates (minutes)			
	Protection Type	Layers	Thickness (in.)	Rim Board Type	Thickness (in.)	Tested GWB + Rim Board Time	Calc'd Rim Board Time	Time Assigned to GWB	Calc'd Rim + GWB Times
2128	< none >	-	-	OSB-C	1.14	29	34	-	34
2130	H - Type X GWB (direct)	1	0.50	OSB-C	1.14	76	34	30	64
2129	K - Type X GWB (direct)	1	0.63	OSB-C	1.14	80	34	40	74
2131	H - Dbl. Type X GWB (direct)	2	1.00	OSB-C	1.14	118	34	60	94
2127	< none >	-	-	LVL	1.22	40	37	-	37

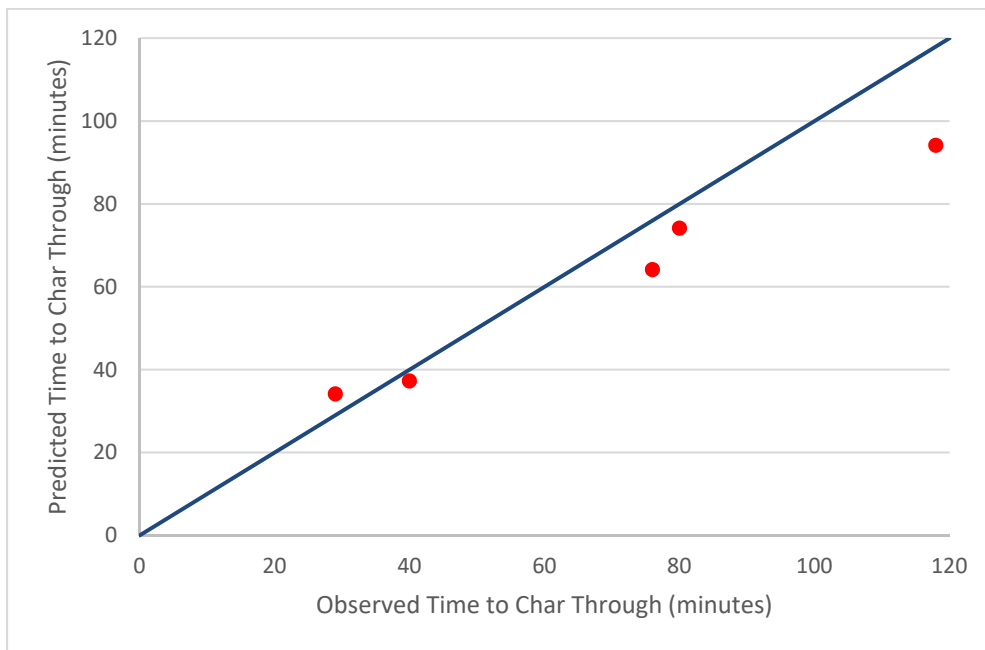

Figure 3-5 Comparison of Predicted to Observed Char-Through Time (Intermediate-Scale Rimboard Tests)

3.6 AWC GWB-Protected Beam Tests

In 2014, AWC funded a series of bending tests on SCL beams at the Western Fire Center (WFC) conducted in accordance with ASTM E119 [43]. The results of six unprotected beam tests were discussed in Section 2.7. Four additional beams, protected with gypsum wallboard (GWB), were also tested. The GWB-protected beams were protected with one or two layers of GWB on the three exposed surfaces (the bottom and sides of the beams) and loaded in flexure to percentages of their design load associated with the matching unprotected beam tests. Two of the beams were tested with one layer of 5/8” Type X GWB protection, and two were protected with two layers of 5/8” Type X GWB [43]. Test results are reported in Table 3.6a.

Table 3.6a Protected and Unprotected SCL Beam Tests – Full-Scale Furnace Test Results

Beam Description	Design Stress Ratio	Test Times (minutes)		
		Unprotected	1 Layer 5/8” Type X GWB	2 Layers 5/8” Type X GWB
3 1/2”-Wide LVL	56%	33	71	--
7”-Wide LVL	113%	50	--	139
3 1/2”-Wide LSL	84%	35	74	114

To determine the fire resistance contribution from 5/8” Type X GWB protection in each test configuration, the fire resistance time for the matching unprotected SCL beam test was subtracted from the fire resistance time of the protected SCL beam test. Based on this comparison, the additional contribution of the 5/8” Type X GWB averaged slightly over 40 minutes. While these tests evaluated the added fire resistance from GWB protection, the installation was intentionally designed to evaluate minimum installation detailing. For example, the vertical GWB surfaces overlapped the horizontal surfaces at the bottom of the beam, which allowed the vertical GWB to curl away from the wood members, exposing wood beneath the GWB earlier than it would have otherwise been exposed on the single-layer tests. Furthermore, the GWB joints and edges were not finished with tape and joint compound. If the GWB joints and edges had been finished, time to failure would have likely been at least 2 minutes longer. All GWB layers were attached with screws located 1” from GWB edges and ends and spaced 12” on center.

To evaluate the final model, the calculated fire resistance of the SCL beam using the design procedure for exposed wood members from Section 4.1 and the additional time assigned to the 5/8” Type X GWB were added together and compared to the tested fire resistance of the assembly in Table 3.6b and Figure 3-6.

Table 3.6b Added Contribution of Gypsum Wallboard Protection

Beam Description	Design Stress Ratio	GWB Description		Test Times (minutes)			Estimated Times (minutes)		
		Thickness (inches)	Layers	SCL Beam + GWB	SCL Beam Only	GWB Only	SCL Beam + GWB	SCL Beam Only	GWB Only
3 1/2”-Wide LVL	56%	5/8” Type X	1	71	33	38 ¹	70	30	40
7”-Wide LVL	113%	5/8” Type X	2	139	50	90	130	50	80
3 1/2”-Wide LSL	84%	5/8” Type X	1	74	35	39 ¹	66	26	40
3 1/2”-Wide LSL	84%	5/8” Type X	2	114	35	79	106	26	80

¹Gypsum wallboard corners were not finished, resulting in early penetration of fire.

When tested in accordance with ASTM E119, all ten SCL beams lasted longer in the fire tests than the calculated fire resistance corresponding to the actual applied load level. Accordingly, test results support the use of the calculation procedure in NDS Chapter 16 and TR10 for SCL. Furthermore, tests of SCL protected by 5/8” Type X GWB support assigning 40 minutes per layer of 5/8” Type X GWB.

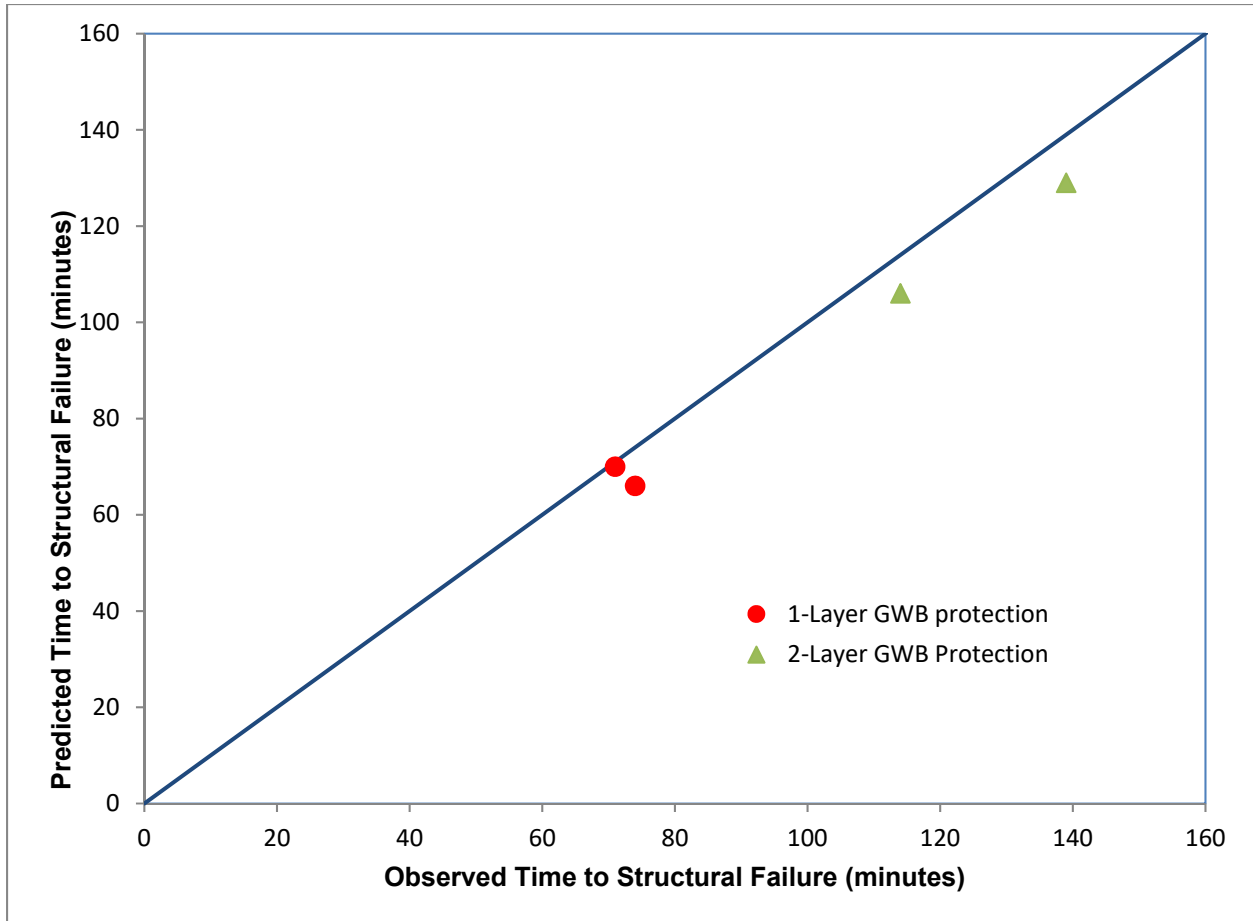

Figure 3-6 Comparison of Predicted to Observed Time to Failure (GWB-protected SCL Beams)

3.7 Cross-Laminated Timber Protected Wall and Floor Tests

Wall and floor tests have been conducted on protected CLT assemblies protected with gypsum wallboard (GWB). Summary descriptions and comparison of these results follows. All CLT in these tests used a polyurethane adhesive available at the time of testing.

3.7.1 NRC Protected CLT Floor and Wall Tests

As discussed in 2.8, in 2011, FPIInnovations (FPI), in collaboration with the National Research Council of Canada (NRC), conducted a series of 8 full-scale fire resistance tests of CLT floors and walls [50]. All tests followed the ULC S101 time-temperature curve, a fire exposure comparable to the ASTM E119 time-temperature curve. Three of the CLT floors and one of the CLT walls were protected with GWB.

As reported in Section 2.8 for unprotected CLT floor and wall tests, loading of the floors and walls was based on Canadian standards. For purposes of this analysis, allowable stress design (ASD) values were determined by using relevant grades from the CLT product standard, PRG-320 [51]. Structural fire resistance was then calculated using NDS design provisions and appropriate ASD design values from PRG-320.

NRC Test #1 - Protected Floor:

The first GWB protected floor test (NRC #1) was a 3-ply CLT slab. Plies were each 1-1/2 inches thick for a total thickness of 4-1/2 inches. This CLT was constructed using SPF 1650f-1.5E lumber for the face laminations and SPF No. 3 grade lumber for the crossing lamination. This construction matched the grade of CLT Grade E2 from PRG-320. The CLT was protected with two layers of 1/2” Type X GWB.

Dead load of the CLT floor was estimated to be 15 psf. A superimposed load of 56 psf was added, resulting in a total load of 71 psf. Using NDS behavioral equations and standard properties from PRG 320, the allowable resisting moment was 4,575 ft-lb/ft. To model this specific test result, additional conservatisms built into the derivation of CLT design values were removed (calculations assumed $C_F = 1.0$, $C_{fu} = 1.10$, $C_V = 1.0$, and removal of the 0.85 bending factor), resulting in an adjusted allowable resisting moment of 5,900 ft-lb/ft. Given a span of 186 inches, the induced moment was 2,150 ft-lb/ft (47% of full ASD design load). Testing was terminated at 77 minutes due to equipment concerns of laboratory staff. Using the provisions developed in Section 2.8, the fire resistance contribution of the CLT was estimated to be 48 minutes; however, since the test was terminated prior to structural failure, there was no way to estimate the contribution of the two layers of 1/2" Type X GWB.

NRC Test #2 - Protected Wall:

The first protected wall test (NRC #2) was a 3-ply CLT slab. Plies were each 1-1/2 inches thick for a total thickness of 4-1/2 inches. This CLT was constructed using SPF 1650f-1.5E lumber for the face laminations and SPF No. 3 grade lumber for the crossing lamination. This construction matched the grade of CLT Grade E2 from PRG-320. The CLT was protected with two layers of 1/2" Type X GWB.

Dead load of the CLT wall was estimated to be 142 plf. A superimposed load of 22,818 plf was added, resulting in a total load of 22,960 plf. Using standard design properties from PRG 320 and NDS behavioral equations assuming an unbraced wall height of 120 inches and a buckling length coefficient, K_e , of 0.7 for concentrically-loaded, square-end columns bearing on a rigid foundation (see justification in Section 2.8), allowable compression capacity was estimated to be 48,620 plf. Structural failure occurred at 106 minutes. Using the provisions developed in Section 2.8, the fire resistance contribution of the CLT was estimated to be 31 minutes, so the contribution of the two layers of 1/2" Type X GWB was estimated to be 75 minutes.

NRC Test #5 - Protected Floor:

The second protected floor test (NRC #5) was a 3-ply CLT slab. Plies were each 1-3/8 inches thick for a total thickness of 4-1/8 inches. This CLT was constructed using SPF No.1/No.2 grade lumber for all laminations. For relevant design properties needed for fire calculations, this construction matched the grade and layup of CLT Grade V2 from PRG-320. The CLT was protected with one layer of 5/8" Type X GWB.

Dead load of the CLT floor was estimated to be 11 psf. A superimposed load of 50 psf was added, resulting in a total load of 61 psf. Using NDS behavioral equations and standard properties from PRG 320, the allowable resisting moment was 2,025 ft-lb/ft. To model this specific test result, additional conservatisms built into the derivation of CLT design values were removed (calculations assumed $C_F = 1.3$, $C_{fu} = 1.15$, $C_V = 1.0$, and removal of the 0.85 bending factor), resulting in an adjusted allowable resisting moment of 3,575 ft-lb/ft. Given a span of 186 inches, the induced moment was 1,850 ft-lb/ft (91% of full ASD design load). The test was terminated at 86 minutes due to burn-through at a half-lap joints at the intersection of CLT panel edges. Using provisions developed in Section 2.8, the fire resistance contribution of the CLT was estimated to be 36 minutes; however, since the test was terminated prior to structural failure, there was no way to estimate the specific contribution of the 5/8" Type X GWB, but it was at least 50 minutes.

NRC Test #6 - Protected Floor:

The third protected floor test (NRC #6) was a 5-ply CLT slab. Plies were each 1-3/8 inches thick for a total thickness of 6-7/8 inches. This CLT was constructed using SPF No.1/No.2 grade lumber for all laminations. For relevant design properties needed for fire calculations, this construction matched the grade and layup of CLT Grade V2 from PRG-320. The CLT was protected with one layer of 5/8" Type X GWB.

Dead load of the CLT floor was estimated to be 18 psf. A superimposed load of 169 psf was added, resulting in a total load of 187 psf. Using NDS behavioral equations and standard properties from PRG 320, the allowable resisting moment was 4,675 ft-lb/ft. To model this specific test result, additional conservatisms built into the derivation of CLT design values were removed (calculations assumed $C_F = 1.3$, $C_{fu} = 1.15$, $C_V = 1.0$, and removal of the 0.85 bending factor) resulting in an adjusted allowable resisting moment of 8,225 ft-lb/ft. Given a span of 186 inches, the induced moment was 5,625 ft-lb/ft (120% of full

ASD design load). The test was terminated at 124 minutes due to burn-through at a half-lap joints at the intersection of CLT panel edges. Using provisions developed in Section 2.8, the fire resistance contribution of the CLT was estimated to be 110 minutes; however, since the test was terminated prior to structural failure, there was no way to estimate the contribution of the 5/8" Type X GWB.

3.7.2 AWC Protected CLT Wall Test

In 2012, AWC funded a protected CLT wall test (NGC-01) at NGC Testing Services [58]. The 5-ply CLT, with 1-3/8 inches thick plies for a total thickness of 6-7/8 inches. The CLT was constructed using SPF 1950f-1.7E for the face laminations and SPF No. 3 grade lumber for the crossing lamination. For relevant design properties needed for fire calculations, this construction matched the grade and layup of CLT Grade E1 from PRG-320.

Dead load of the CLT wall was estimated to be 92 plf. A superimposed load of 8,608 plf was added, resulting in a total load of 8,700 plf. NDS behavioral equations assume that the char layer will fall off when the char front reaches the glue-line; however, since the GWB was attached with 2-1/4" drywall screws spaced 12" on center, the first lamination was assumed to stay in place. Using standard design properties from PRG 320, modified assumptions about char layer fall off, and NDS behavioral equations assuming an unbraced wall height of 120 inches and a buckling length coefficient, $K_e = 0.7$ for concentrically-loaded, square-end columns bearing on a rigid foundation, the allowable compression capacity was estimated to be 83,160 plf. Structural failure occurred at 184 minutes. Using the provisions developed in Section 2.8, the fire resistance contribution of the CLT was estimated to be 141 minutes, so the contribution of the single layer of 5/8" Type X GWB was estimated to be 43 minutes.

3.7.3 AWC Protected CLT Floor Tests

In 2017, AWC funded a series of CLT floor tests at Western Fire Center (WFC) specifically designed to estimate the added fire resistance provided by Type X GWB when applied to the ceiling (fire exposed side) of a CLT floor/ceiling assembly [59]. The 5-ply CLT, with 1-3/8 inches thick plies, had a total thickness of 6-7/8 inches. The CLT was constructed using visually graded No. 2 SPF-S lumber, with relevant design properties as specified for Grade SL-V4 in APA Product Report PR-L319 [60]. A description of the three CLT floor assemblies in the series are as follows:

1. Unprotected CLT floor/ceiling assembly
2. CLT floor/ceiling assembly protected with a single layer of 5/8" Type X GWB directly attached to the CLT with 1-5/8" drywall screws spaced 12" o.c. in each direction with perimeter screws 1-1/2" from the edge.
3. CLT floor/ceiling assembly protected with three layers of 5/8" Type X GWB. The base layer was directly attached to the CLT with 1-5/8" drywall screws spaced 12" o.c. in each direction with perimeter screws 1-1/2" from the edge. The second layer was offset from the base layer ends and edges by 4 inches and attached to the CLT with 2-1/4" drywall screws spaced 12" o.c. in each direction with perimeter screws 1-1/2" from the edge. The face layer was offset from the second layer ends and edges by 4 inches and attached to the CLT with 3" drywall screws spaced 12" o.c. in each direction with perimeter screws 1-1/2" from the edge.

Dead load of the CLT floor assemblies was estimated to be approximately 15 psf for the unprotected assembly, 17.6 psf for the single-GWB-layer assembly, and 21.6 psf for the three-GWB-layer assembly. A superimposed load of 60 psf was added, resulting in a total load of 75, 78, and 82 psf, respectively. As specified in APA Product Report PR-L319, the allowable resisting moment is 4,150 ft-lb/ft. Given a strong axis span of 215 inches, the induced moment in the single-layer assembly was 3,125 ft-lb/ft (75% of full ASD design load). The induced moment was slightly greater in the three-layer assembly, due to dead load of the additional GWB layers.

Given the mass of CLT assemblies, E119 fire resistance tests of protected CLT floor/ceiling assemblies are difficult to run to structural failure. As mentioned in 3.7.1, the NRC floor-ceiling tests were terminated early due to burn-through of the floor slab at uncaulked CLT panel edge joints. While burn-through is a termination criterion in ASTM E119, it does not allow an accurate estimate of the fire resistance

contribution of the protection elements since burn-through time can be a function of detailing and quality of the edge joints.

In this series of fire tests, a single spline joint running the full length of the assembly was caulked with 5 layers of intumescent caulk. However, due to the crossing laminations spanning the furnace in the weak direction, the CLT assembly continued to support the load well beyond the expected fire resistance time estimated using strong axis flexural properties alone. Centerpoint deflections from the three tests are provided in Figure 3-7. Each test was terminated when the centerpoint deflection of the CLT assembly exceeded 12 inches. Based on the fact that structural failure occurred approximately 1 minute after the test was terminated on the three-layer test, a centerpoint deflection of 12 inches was determined to be a consistent comparison point at which structural failure was imminent for this particular test series. Centerpoint deflections of 12 inches was reached at 149, 190, and 277 minutes for the unprotected, single layer GWB, and three-layer GWB CLT floor/ceiling assemblies, respectively. The protection contribution of 5/8" Type X GWB is determined by subtracting the unprotected CLT floor/ceiling assembly fire resistance time of 149 minutes from the fire resistance times of the GWB-protected assemblies. The contribution of the single layer of 5/8" Type X GWB protection was 41 minutes and the contribution of three layers of 5/8" Type X GWB protection was 127 minutes (42 minutes per layer).

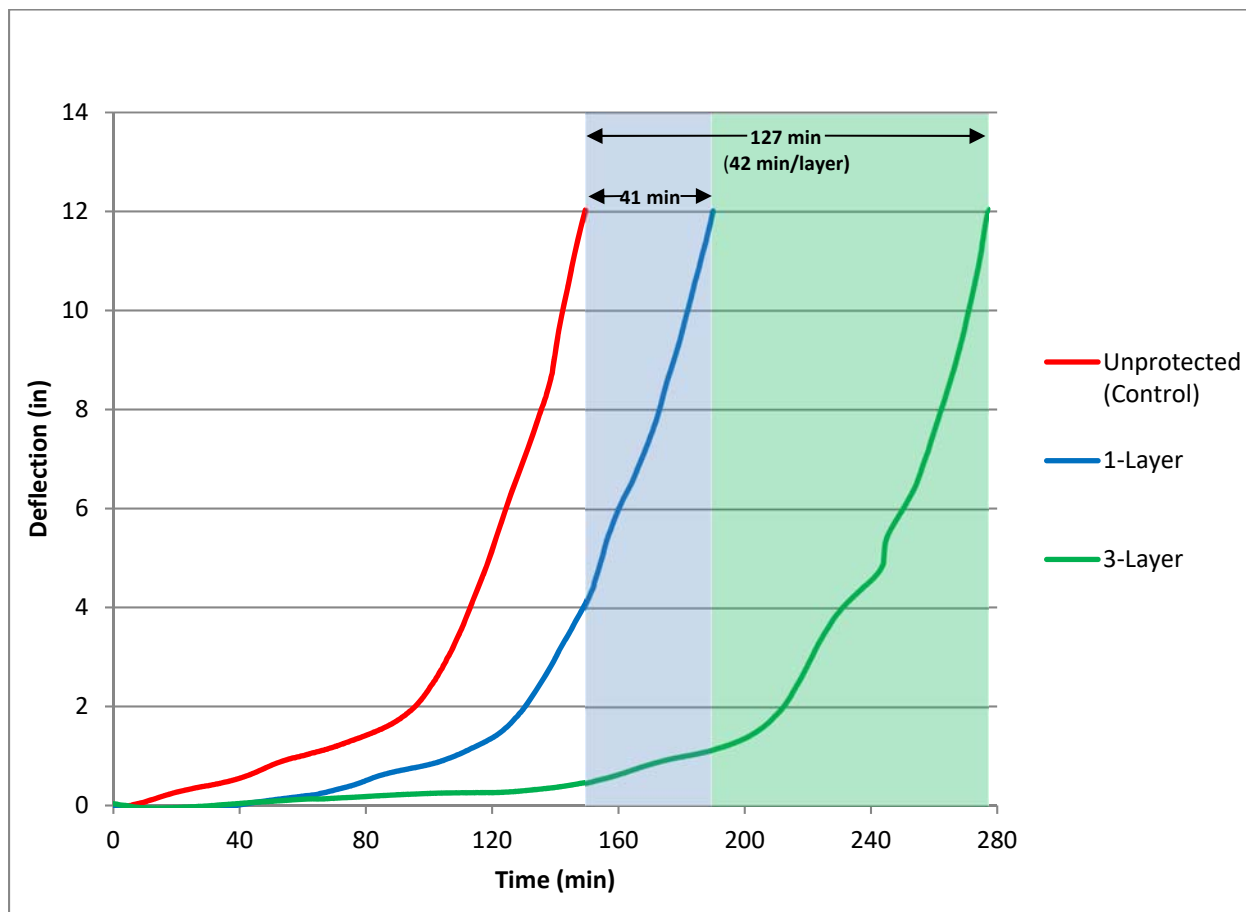

Figure 3-7 Vertical Deflection at Centerpoint of CLT Floor/Ceiling Assembly

3.7.4 Results of Analysis

The fire resistance of each protected CLT assembly is provided in Table 3.7a. For test results provided in 3.7.1 and 3.7.2, the fire resistance contribution of the CLT was estimated using the provisions developed in Section 2.8. For test results provided in 3.7.3, the fire resistance contribution of the CLT was determined directly in the unprotected CLT floor-ceiling assembly test, loaded to the same load level. A comparison of the estimated contribution of the GWB protection to the total measured fire resistance time is provided in Table 3.7b. Tests of CLT protected with Type X GWB support an assignment of 40 minutes

per layer to 5/8” Type X GWB and 30 minutes per layer to 1/2” Type X GWB as provided in Table 3.7c and Figure 3-8.

Table 3.7a Description of CLT Floor/Ceiling Assemblies

Designation	Application	CLT			Gypsum Wallboard		Test Time (min)
		Species	Thickness (in.)	ASD Stress Ratio	Type & Thickness	Number of Layers	
NRC #1	Floor	SPF	4.5	0.47	1/2” Type X	2	77 ¹
NRC #2	Wall	SPF	4.5	0.47	1/2” Type X	2	106
NRC #5	Floor	SPF	4.125	0.91	5/8” Type X	1	86 ²
NRC #6	Floor	SPF	6.875	1.20	5/8” Type X	1	124 ²
NGC-01	Wall	SPF	6.875	0.10	5/8” Type X	1	184
WFC 1	Floor	SPF	6.875	0.75	[none]	0	149 ³
WFC 2	Floor	SPF	6.875	0.75	5/8” Type X	1	190 ³
WFC 3	Floor	SPF	6.875	0.75	5/8” Type X	3	277 ³

¹ Test halted at 77 minutes due to laboratory equipment concerns.

² Test halted due to burn-through at CLT panel half-lap joint.

³ Test halted at 12” of vertical deflection at centerpoint of floor/ceiling assembly.

Table 3.7b Contribution of GWB to Fire Resistance Times

Designation	Application	Test Time (min)	CLT Time (min)	Gypsum Wallboard				
				Type & Thickness	Number of Layers	Added Time (min)	Added Time per Layer (min)	Assigned Time per Layer (min)
NRC #1	Floor	77 ¹	43 ⁴	1/2” Type X	2	-	-	30
NRC #2	Wall	106	31 ⁴	1/2” Type X	2	75	37	30
NRC #5	Floor	86 ²	36 ⁴	5/8” Type X	1	-	-	40
NRC #6	Floor	124 ²	110 ⁴	5/8” Type X	1	-	-	40
NGC-01	Wall	184	140 ⁴	5/8” Type X	1	44	44	40
WFC 2	Floor	190 ³	149 ³	5/8” Type X	1	41	41	40
WFC 3	Floor	277 ³	149 ³	5/8” Type X	3	127	42	40

¹ Test halted at 77 minutes due to laboratory equipment concerns.

² Test halted due to burn-through at CLT panel half-lap joint.

³ Test halted at 12” of vertical deflection at centerpoint of floor/ceiling assembly.

⁴ A nominal char rate of 1.5 inches/hr was assumed.

Table 3.7c Measured and Calculated CLT Structural Fire Resistance Times

Designation	Application	Gypsum Wallboard		Test Time (min)	Estimated Fire Resistance Times		
		Type & Thickness	Number of Layers		CLT ¹ (min)	GWB ² (min)	Total (min)
NRC #2	Wall	1/2" Type X	2	106	33	60	91
NGC-01	Wall	5/8" Type X	1	184	143	40	180
WFC 2	Floor	5/8" Type X	1	190	149	40	189
WFC 3	Floor	5/8" Type X	3	277	149	120	269

¹ A nominal char rate of 1.5 inches/hr was assumed.

² Estimate based on assigned values of 30 and 40 minutes per layer for 1/2" and 5/8" Type X GWB.

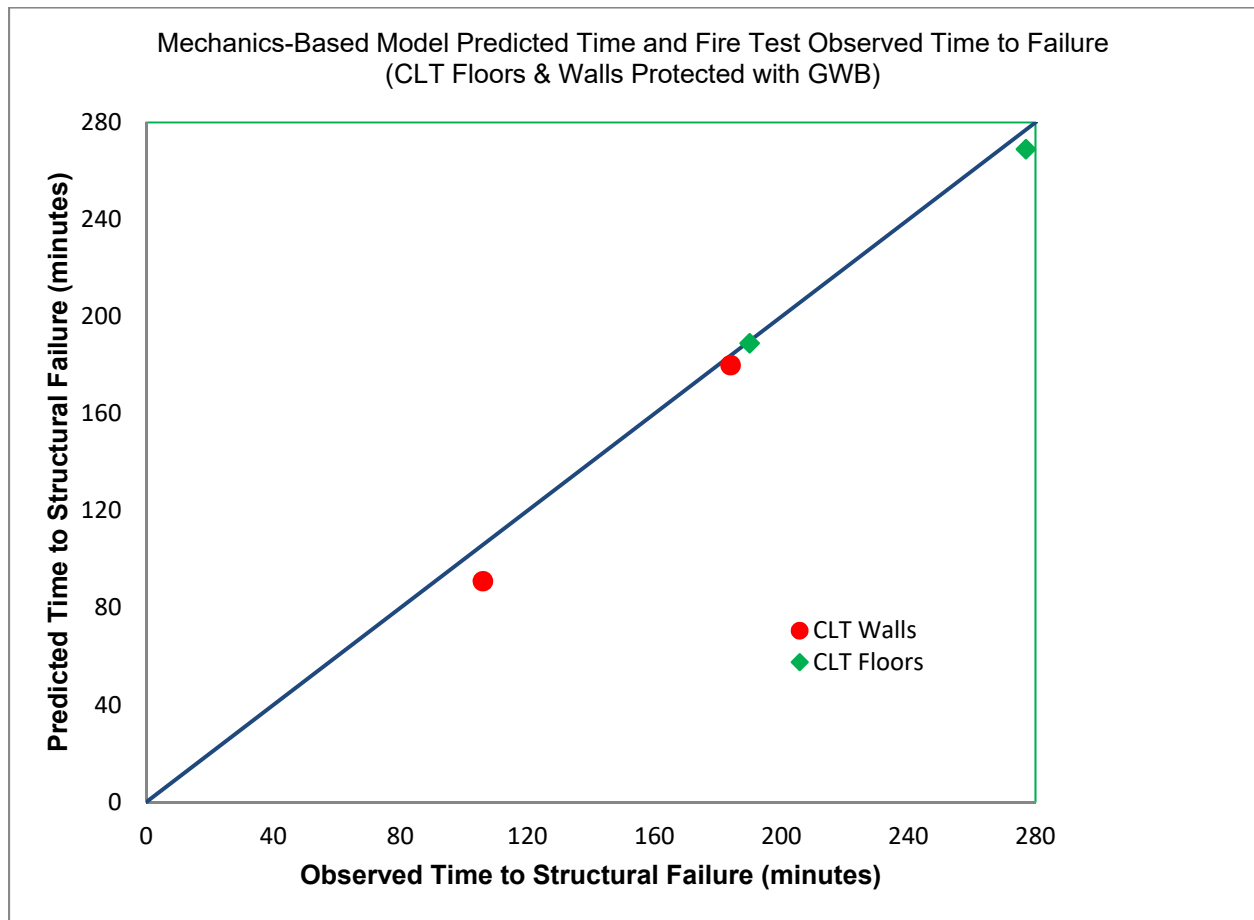

Figure 3-8 Comparison of Predicted to Observed Time to Failure (CLT tests)

3.8 SUMMARY

The results of comparative testing and analysis confirm the contribution of various protective materials to the total fire resistance time when an assembly is subjected to an ASTM E119 fire exposure. In this report, three protective element types were evaluated: solid wood (lumber, LVL, plywood, and OSB), Type X gypsum wallboard (GWB), and insulation (mineral wool and fiberglass batts).

3.8.1 Wood

Added fire resistance time for wood members protecting wood assemblies or wood structural elements was reviewed. Protection provided by extra wood, either by using larger members or adding wood layers attached directly to structural members, can be directly calculated using the char rate relationship in 4.1.1.2. The added fire resistance time, t_p , associated with the additional wood layer can be calculated as:

$$t_p = \left(\frac{d}{\beta_t}\right)^{1.23}$$

Where:

- d = depth of the protective layer of wood (inches)
- β_t = non-linear char rate constant (in/hr^{0.813})

For a nominal char rate of 1.5 inches/hr, which has been demonstrated applicable to lumber, glulam, SCL and CLT, the non-linear char rate constant is $\beta_t = 1.5 \text{ in/hr}^{0.813}$ and the equation to calculate the time associated with a protective wood membrane of a thickness, d, is as follows:

$$t_p = 60 \left(\frac{d}{1.5}\right)^{1.23} \text{ minutes}$$

To account for “element char-through” (ECT) in wood elements providing a barrier, an ECT model was developed. The ECT model uses an accelerated char rate as the char front approaches the unexposed, unbacked surface of a wood slab. In the ECT model, the non-linear char equation is used until the remaining depth of uncharred wood reaches a depth of 0.6 inches, at which time the char rate increased to a linear char rate of 2.1 inches/hour (17 minutes of additional fire resistance after 0.6 inches char depth is reached). The equation to calculate the time associated with char-through of a one-dimensional element is as follows:

$$t_p = \left[60 \left(\frac{d - 0.6}{1.5}\right)^{1.23} + 17 \right] \text{ minutes for } d \geq 0.6 \text{ inches}$$

$$t_p = 60 \left(\frac{d}{2.1}\right) \text{ minutes for } d < 0.6 \text{ inches}$$

Where wood is used to provide thermal separation, the assigned thermal separation time was found to be less than the added fire resistance time attributable to the wood protection. In Section 3.5 Rimboard Tests, analysis indicated that the time to reach the thermal resistance threshold, an average thermocouple temperature rise of 139°C (250°F) or a single thermocouple rise of 181°C (325°F), averaged 88% of the time to reach the char temperature of 300°C (572°F) and the added fire resistance time.

Where char contraction can limit the ability of a wood element to provide the added fire resistance time or thermal separation time, detailing should take into account the provisions of 1.5.1.

3.8.2 Gypsum Wallboard

A summary of tested E119 fire resistance times and assigned times for wood structural elements, insulation (if present), and Type X GWB protection are provided in Table 3.8a. On average, 1/2" Type X GWB provided approximately 36 minutes/layer (COV=0.19) and 5/8" Type X GWB provided approximately 44 minutes/layer (COV=0.11). These results support assigned fire resistance contribution values of 30 and 40 minutes/layer, respectively, when installed with at a maximum fastener spacing of 12" on center. Tests of GWB protected wood stud walls indicated that tighter fastener spacings increased the contribution of the GWB, a significant issue for some light-framed wall designs, but tighter spacings was not studied in other configurations, so no broadly applicable design recommendation is made for protected wood assemblies or members. Increased fastener penetration depth used to secure GWB increases the time that GWB can remain in place after the wood beneath begins to char and has also been recognized as significant for wood stud walls. Recent wood stud wall fire tests used 2-1/4" drywall screws to attach 5/8" Type X GWB, thus providing 1-5/8" of penetration into wood studs; however, most of the remaining tests in this analysis utilized drywall screws that provided only a minimum of 1" of penetration into wood or were attached to resilient channels. Specific rated assemblies, protected with Type X GWB have achieved fire resistance times greater than those provided in this report and, when used, should be constructed with the same fastener spacings and fastener penetrations used in the supporting fire tests.

Where GWB is used for thermal separation, the assigned thermal separation time is less than the added fire resistance time attributable to GWB protection. In Section 3.5 Rimboard Tests, analysis indicates that the time to reach the thermal resistance threshold, that was chosen as an average thermocouple temperature rise of 139°C (250°F) or a single thermocouple rise of 181°C (325°F), averaged 82% of the time to reach the char temperature of 300°C (572°F) and approximately 50% of the added fire resistance time.

Where panel contraction can limit the ability of GWB to provide the full added fire resistance time or thermal separation time, detailing should take into account the amount of shrinkage expected, noting that some proprietary Type X GWB products use additives that aid in reducing contraction. Results from E119 fire resistance tests of GWB protected assemblies inherently account for this contraction; therefore, detailing of assemblies based on these existing E119 tests should match the tested configuration.

Table 3.8a Summary of Fire Resistance Testing of GWB Protected Members and Assemblies

Assembly	Framing Element	Test Duration (min.)	Time Framing Alone (min.)	Time Cavity Ins. (min.)	GWB (Type X)						
					No. Layers	Thick-ness (in.)	Fastener Spacing (in.)	Time GWB (min.)	GWB Time/Layer (min.)		
								1/2"	5/8"		
Wall Studs	NGC WP-1229 (07-22-99)	2x6 studs @ 16" oc (5.5" MWI)	79	14	16	1	5/8	7"	49	49	
	NGC WP-1231 (09-14-99)	2x6 studs @ 16" oc (5.5" MWI)	70	14	16	1	5/8	12"	40	40	
	NGC WP-1232 (09-16-99)	2x6 studs @ 16" oc (no ins.)	64	14		1	5/8	7"	50	50	
	NGC WP-1345 (08-20-03)	2x6 studs @ 16" oc (R-19 FGI)	58	14	3	1	5/8	12"	41	41	
	NGC WP-1346 (08-22-03)	2x6 studs @ 16" oc (R-19 FGI)	61	14	3	1	5/8	12"	44	44	
	NGC WP-1259 (10-18-00)	2x6 studs @ 24" oc (no ins.)	104	14		2	5/8	8"	90	45	
	NGC WP-1262 (11-03-00)	2x6 studs @ 24" oc (5.5" MWI)	123	14	16	2	5/8	8"	94	46.5	
	NGC WP-1242 (02-23-00)	2x4 studs @ 16" oc (3.5" MWI)	71	10	13	1	5/8	7"	48	48	
	NGC WP-1248 (03-29-00)	2x4 studs @ 16" oc (3.5" MWI)	65	10	13	1	5/8	12"	42	42	
	NGC WP-1249 (03-31-00)	2x4 studs @ 16" oc (no ins.)	58	10		1	5/8	7"	48	48	
	NGC WP-1260 (10-20-00)	2x4 studs @ 16" oc (no ins.)	56	10		1	5/8	7"	46	46	
NGC WP-1407 (08-11-04)	2x4 studs @ 16" oc (R-13 FGI)	56	10	2	1	5/8	7"	44	44		
MPC Trusses	FM FC-214 (07-06-78)	12" PCT @ 24" oc 1.5" x 3.5" chords (no ins.)	69	10		2	1/2	12"	59	29.5	
	FM FC-235 (08-06-76)	12" PCT @ 24" oc 1.5" x 3.5" chords (no ins.)	50	10		1	5/8	12"	40	40	
	FM FC-249 (04-13-77)	12" PCT @ 24" oc 1.5" x 3.5" chords (no ins.)	58	10		1	5/8	12"	48	48	
	UL R9500-1 (02-02-81)	12" PCT @ 24" oc 1.5" x 3.5" chords (no ins.)	61	10		1	5/8	12"	51	51	
	FM FC-426 (1986)	14" PCT @ 24" oc 1.5" x 3.5" chords (no ins.)	112	10		2	5/8	12"	102	51	
I-Joists	WHI-651-0311.1 (02-09-90)	11-1/4" IJ @ 24" oc 1.5" x 3.5" Flange (1.5" MWI)	60	20		1	5/8	12"	40	40	
	WHI-694-0159 (06-19-84)	9-1/4" IJ @ 24" oc 1.5" x 3.5" Flange (1.5" MWI)	60	20		1	5/8	12"	40	40	
	UL NC3369 (09-28-01)	9-1/4" IJ @ 24" oc 1.31" x 1.75" Flange (2" MWI)	65	20		1	5/8	7"	45	45	
	NGC FC-687 (02-25-07)	9-1/4" IJ @ 24" oc 1.5" x 1.5" Flange (no ins.)	64	3		2	1/2	12"	61	30.5	
	NRC A-4440.1 (06-24-97)	9-1/2" IJ @ 24" oc 1.5" x 1.5" Flange (no ins.)	75	3		2	1/2	12"	72	36	
	NRC A-4219.13.2 (03-23-98)	9-1/4" IJ @ 24" oc 1.5" x 1.5" Flange (3.5" FGI)	74	6		2	1/2	12"	68	34	
PFS #92-56 (12-16-92)	9-1/4" IJ @ 24" oc 1.5" x 1.5" Flange (3.5" FGI)	122	6		3	5/8	8"	116	38.7		
Rim-Joists	FPL-RP-610 Test 1718	1.14" thick OSB	65	34		1	1/2	9"	31	31	
	FPL-RP-610 Test 1735	1.14" thick OSB	89	34		1	5/8	9"	55	55	
	FPL-RP-610 Test 1706	1.14" thick OSB	76	34		1	5/8	9"	42	42	
	FPL-RP-610 Test 1709	1.14" thick OSB	70	34		1	5/8	9"	36	36	
	FPL-RP-610 Test 1719	1.14" thick OSB	125	34		2	1/2	9"	91	45.5	
	FPL-RP-610 Test 1710	1.14" thick OSB	134	34		2	5/8	9"	100	50	
	FPL-RP-610 Test 1707	0.94" thick Plywood	65	27		1	5/8	9"	38	38	
	FPL-RP-610 Test 1708	0.94" thick Plywood	65	27		1	5/8	9"	38	38	
	FPL-RP-610 Test 1711	0.94" thick Plywood	117	27		2	5/8	9"	90	45	
	FPL-RP-610 Test 1720	1.10" thick OSB	57	33		1	1/2	9"	24	24	
	FPL-RP-610 Test 1722	1.10" thick OSB	66	33		1	5/8	9"	33	33	
	FPL-RP-610 Test 1721	1.10" thick OSB	117	33		2	1/2	9"	84	42	
	FPL-RP-610 Test 2130	1.14" x 23.2" OSB	76	33		1	1/2	12"	43	43	
	FPL-RP-610 Test 2129	1.14" x 23.2" OSB	80	33		1	5/8	12"	47	47	
FPL-RP-610 Test 2131	1.14" x 23.2" OSB	118	33		2	1/2	12"	85	42.5		
Beams	WFCi Report #14035	3.5"x 9.5" LVL	71	33		1	5/8	12"	38	38	
		7"x 9.5" LVL	139	50		2	5/8	12"	89	44.5	
		3.5"x 9.5" LSL	74	35		1	5/8	12"	39	39	
		3.5"x 9.5" LSL	114	35		2	5/8	12"	79	39.5	
CLT Walls	NRC #2	4-1/2" (3-ply) CLT	106	31		2	1/2	12"	75	37.5	
	NGC-01	6-7/8" (5-ply) CLT	184	141		1	5/8	12"	43	43	
CLT Floors	WFCi Report #17091	6-7/8" (5-ply) CLT	190	149		1	5/8	12"	41	41	
		6-7/8" (5-ply) CLT	277	149		3	5/8	12"	128	42.7	
									n	11	36
									Average	36	43.6
									COV	0.19	0.11
									Assigned	30	40

3.8.3 Insulation

Added fire resistance times for assemblies using insulation to protect wood elements were reviewed in wall and I-joist floor assemblies. Since there were different elements, conditions of exposure, thermal protection, and size for each test specimen, added fire resistance contribution was estimated by iteratively solving for the time delay provided to the protected wood surface. In the stud model, mineral wool insulation (2.5 pcf) and fiberglass insulation (R-13) were found to provide 19 and 3-minute delays, respectively, when the cavity between 2x4 and 2x6 studs were filled (Table 3.3f). For the I-joist model, mineral wool insulation (1.5 to 2-inch thick, 2.5 pcf) and fiberglass insulation (3.5-inch thick, R-13) were found to provide 17 and 3-minute delays, respectively, when the surfaces of the wood members were protected either directly or indirectly (see Table 3.4b).

Part IV: Design Procedures for Exposed and Protected Wood Members

4.1 Design Procedures for Exposed Wood Members

Failure of a member occurs when the load on the member exceeds the member capacity which has been reduced due to fire exposure. This mechanics-based design procedure calculates the capacity of exposed wood members using basic wood engineering mechanics and was originally incorporated into the 2001 *National Design Specification® for Wood Construction (NDS®)* [25] for fire resistance calculations of up to 2 hours. Actual mechanical and physical properties of the wood are used, and the capacity of the member is directly calculated for a given period of time. Section properties are computed assuming an effective char depth, a_{eff} , calculated at a given time assuming a non-linear char rate. Reductions of strength and stiffness of wood directly adjacent to the char layer and rounding at exposed edges are addressed by using an effective char depth that is 20% greater than the actual char depth. Average member strength properties are approximated from existing accepted procedures used to calculate design properties. Finally, wood members are designed using accepted engineering procedures found in the *NDS* [9].

4.1.1 Char Rate

4.1.1.1 The non-linear char rate to be used in this procedure is estimated from published nominal one-hour char rate data using the following equation:

$$\beta_t = \beta_n \frac{(1 \text{ hr})}{(1 \text{ hr})^{0.813}} \quad (\text{Equation 4.1-1})$$

Where:

- β_t = Non-linear char rate constant (in/hr^{0.813})
- β_n = Nominal char rate constant (in/hr), linear char rate based on 1-hour exposure
- t = Exposure time (hr)

A nominal char rate, β_n , of 1.5 inches/hour is applicable for sawn lumber and timbers, glued-laminated timbers, laminated veneer lumber, parallel strand lumber, laminated strand lumber, and cross-laminated timber.

4.1.1.2 For sawn lumber and timbers, glued-laminated timbers, laminated veneer lumber, parallel strand lumber, and laminated strand lumber, the char depth, a_{char} , for each exposed surface is calculated as:

$$a_{char} = \beta_t t^{0.813} \quad (\text{Equation 4.1-2})$$

4.1.1.3 For cross-laminated timber, fall-off of char has been noted during full-scale tests. The fall-off appears to occur as the char front approaches the glueline. To model this effect, the time required to reach the glueline for each lamination is calculated as:

$$t_{gl,i} = \left(\frac{h_{lam,i}}{\beta_t} \right)^{1.23} \quad (\text{Equation 4.1-3})$$

Where:

- $t_{gl,i}$ = time to reach glued interface for each lamination (hr.)

h_{lam} = lamination thickness (in.)

The number of laminations that could potentially fall off in this manner is estimated by subtracting each t_{gl} from the total time until the last partial lamination is determined. The value of n_{lam} is the maximum value in which the following equation is true:

$$t - \sum_{i=1}^{n_{lam}} t_{gl,i} \geq 0 \quad \text{(Equation 4.1-4)}$$

Where:

n_{lam} = number of laminations charred (rounded to lowest integer)

The values of $t_{gl,i}$ and n_{lam} determined in the above equations are used to calculate the char depth, a_{char} :

$$a_{char} = \sum_{i=1}^{n_{lam}} h_{lam,i} + \beta_t \left(t - \sum_{i=1}^{n_{lam}} t_{gl,i} \right)^{0.813} \quad \text{(Equation 4.1-5)}$$

For cross-laminated timber manufactured with laminations of equal thickness, calculation of the char depth, a_{char} , can be simplified as follows:

$$a_{char} = n_{lam} \cdot h_{lam} + \beta_t \left(t - (n_{lam} \cdot t_{gi}) \right)^{0.813} \quad \text{(Equation 4.1-6)}$$

Where:

$$t_{gi} = \left(\frac{h_{lam}}{\beta_t} \right)^{1.23} \quad \text{(Equation 4.1-7)}$$

and

$$n_{lam} = \frac{t}{t_{gi}} \quad \text{(Equation 4.1-8)}$$

4.1.1.4 For structural calculations, section properties are calculated using standard equations for area, section modulus and moment of inertia using the reduced cross-sectional dimensions. The dimensions are reduced by the effective char depth, a_{eff} , for each surface exposed to fire, where:

$$a_{eff} = 1.2 a_{char} \quad \text{(Equation 4.1-9)}$$

For sawn lumber and timbers, glued-laminated timbers, laminated veneer lumber, parallel strand lumber, and laminated strand lumber, assuming a nominal char rate, $\beta_n=1.5$ in./hr, the char depth, a_{char} , and effective char depth, a_{eff} , are shown in Table 4.1.1.4A.

**Table 4.1.1.4A Char Depth and Effective Char Depth
(for $\beta_n = 1.5$ inches/hour)**

Required Fire Resistance (hr)	Char Depth, a_{char} (in.)	Effective Char Depth, a_{eff} (in.)
1-Hour	1.5	1.8
1½-Hour	2.1	2.5
2-Hour	2.6	3.2

For cross-laminated timber manufactured with laminations of equal thickness and assuming a nominal char rate, β_n , of 1.5 in./hr, the char depth and the effective char depth for each exposed surface is shown in Table 4.1.1.4B:

Table 4.1.1.4B Effective Char Depth (for CLT with $\beta_n=1.5$ inches/hour)

Required Fire Resistance (hr)	Lamination Thickness, h_{lam} (in.)								
	5/8	3/4	7/8	1	1-1/4	1-3/8	1-1/2	1-3/4	2
	Char Depth, a_{char} (in.)								
1-Hour	<u>1.8</u>	1.8	1.7	1.7	1.7	1.6	1.5	1.5	1.5
1½-Hour	<u>2.8</u>	2.7	2.6	2.5	2.4	2.4	2.4	2.3	2.2
2-Hour	<u>3.7</u>	3.6	3.4	3.4	3.2	3.2	3.0	3.0	3.0
	Effective Char Depth, a_{eff} (in.)								
1-Hour	<u>2.2</u>	2.2	2.1	2.0	2.0	1.9	1.8	1.8	1.8
1½-Hour	<u>3.4</u>	3.2	3.1	3.0	2.9	2.8	2.8	2.8	2.6
2-Hour	<u>4.4</u>	4.3	4.1	4.0	3.9	3.8	3.6	3.6	3.6

For cross-laminated timber, reduced section properties must account for the influence of char depth on actual laminations. Unlike other laminated wood products with the strength axis oriented in one major axis, the influence of the material lost due to charring on cross-laminated timber has more influence on laminations oriented along the axis being stressed and less in the perpendicular axis. While product standards have developed models for the effects of the lamination properties in the major and minor strength axis, the effect of char depth has not been included. Therefore, effects of the char depth on actual section properties should be calculated using equations provided by the cross-laminated timber manufacturer based on the actual layup used in the manufacturing process. For an approximate conservative estimate, the procedures in 4.4.1.1.3 can be used to determine which laminations will char and thinner cross-laminated members of the same configuration and the same number of laminations as the remaining uncharred laminations can be used.

4.1.2 Approximation of Average Ultimate Strength and Capacity

For fire design, the estimated average ultimate capacity of a member is based on the reduction of cross-section and mechanical properties as a result of fire exposure. While the loss of cross-section and reduction of mechanical properties are addressed by reducing the section properties using the effective char layer thickness, average ultimate strengths must be determined from published allowable stress design (ASD) values at NDS reference conditions (ASD reference values). The average ultimate capacity of a wood member exposed to fire for a given time, t , is estimated using the average ultimate strengths and reduced cross-sectional properties. For sawn lumber and timbers, glued-laminated timbers, structural composite lumber, and cross-laminated timber members, the average ultimate strength can be approximated by multiplying the ASD reference values by the following adjustment factors, K :

Table 4.1.2 ASD Reference Value to Average Ultimate Strength Adjustment Factor

Member Strength	<i>K</i> ¹
Bending	2.85
Tension	2.85
Shear	2.75
Compression	2.58
Beam Buckling	2.03
Column Buckling	2.03

¹ Average ultimate strengths shall not be adjusted for *C_D*, *C_M*, nor *C_t* since these adjustments are addressed in the *K* factors and design methodology.

Axial/bending interactions can be calculated using this procedure. All average ultimate strength and cross-sectional properties should be adjusted prior to structural interaction calculations. The interaction calculations should then be conducted in accordance with appropriate *NDS* provisions.

4.1.3 Design of Members

Once average ultimate capacities have been determined using the effective section properties from Section 4.1.1 and the average ultimate strength approximations from Section 4.1.2, the wood member can be designed using accepted *NDS* design procedures for the following loading condition:

$$D + L \leq KR_{ASD} \quad \text{(Equation 4.1-10)}$$

Where;

- D* = Design dead load
- L* = Design live load
- R_{ASD}* = Nominal allowable design capacity
- K* = Factor to adjust from ASD reference value to average ultimate strength

4.2 Design Procedures for Timber Decks

Timber decks consist of planks that are at least 2 in. (nominal) thick. The planks span between supporting beams and can be arranged in different ways depending on the available lengths [20]. Usually, a single or double tongue-and-groove joint is used to connect adjoining planks, but splines or butted joints are also common.

In order to meet requirements for a given fire resistance rating, a timber deck needs to maintain its thermal separation function and load carrying capacity for the specified duration of exposure to standard fire conditions. The thermal separation requirement limits the temperature rise on the unexposed side of the deck to 250 °F above ambient temperature over the entire surface area, or 325 °F above ambient temperature at a single location. When the limits cannot be met by the decking alone, additional floor coverings can be used to increase the thermal separation time. The calculation procedures in this section do not address the adequacy of thermal separation.

Proper design requires that the deck support the specified load for the required resistance time. The structural design procedures described in Section 4.1 also apply to timber decks provided the uncharred thickness of the deck is greater than 0.6 inches. Single and double tongue-and-groove (T&G) decking should be designed as an assembly of wood beams fully-exposed on one face. Butt-jointed decking should be designed as an assembly of wood beams partially-exposed on the sides and fully-exposed on one face. To compute the effects of partial exposure of the decking on its sides, the char rate for this partial exposure should be reduced to 33% of the effective char rate.

4.3 Special Provisions for Glued Laminated Timber Beams

For structural glued laminated timber bending members that are required to have a fire-resistance rating and are manufactured with multiple lamination grades throughout the depth, the following layup requirements shall apply in addition to any requirements of the structural design:

1. Where the top of the beam will be exposed to fire, a balanced layup shall be specified.
2. Where the top of the beam will not be exposed to fire, an unbalanced layup shall be permitted, except as required by structural design.
3. For structural glued laminated timber bending members required to have a fire resistance rating of up to 1 hour, the beam shall be manufactured to the specified layup except that:
 - a. For unbalanced beams, a nominal 2-inch core lamination shall be removed and an additional nominal 2-inch outer tension lamination shall be placed adjacent to the outer tension lamination (Figure 4-1b).
 - b. For balanced beams, two nominal 2-inch core laminations shall be removed and an additional nominal 2-inch outer tension lamination shall be placed adjacent to the outer tension lamination at the top and bottom of the beam (Figure 4-2b).
4. For structural glued laminated timber bending members required to have a fire resistance rating of greater than 1 hour, the beam shall be manufactured to the specified layup except that:
 - a. For unbalanced beams, two nominal 2-inch core lamination shall be removed and two additional nominal 2-inch outer tension laminations shall be placed adjacent to the outer tension lamination (Figure 4-1c).
 - b. For balanced beams, four nominal 2-inch core laminations shall be removed and two additional nominal 2-inch outer tension laminations shall be placed adjacent to the outer tension lamination at the top and bottom of the beam (Figure 4-2c).

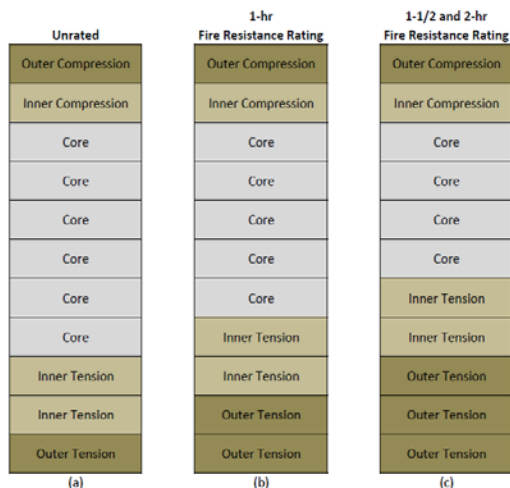

Figure 4-1 Typical Unbalanced Beam Layout



Figure 4-2 Typical Balanced Beam Layout

4.4 Protection of Wood Structural Members and Connections

The addition of protective materials to the surface of a wood member delays the onset of charring for the protected surface. Where protective materials are used to increase the fire resistance of structural wood members and connections, the protection time, t_p , from the protective material which delays charring of the protected surface shall be determined either by testing or engineering based on assigned values. Protection times assigned in 4.4.1 through 4.4.3 are calculated for exposed structural wood members in 4.1 through 4.3 based on the surfaces protected. Where all surfaces are protected by the protective material, the protection time is directly additive. Where protection is providing thermal separation to meet the requirements of ASTM E119 (average temperature rise on the unexposed side of the wood is limited to 250 °F (139 °C) above ambient temperature over the entire surface area, or 325 °F (181 °C) above ambient temperature at a single location), the added contribution of the protection to the thermal separation time shall be calculated per 4.4.1.3, 4.4.2.3, and 4.4.3.2 for wood protection, Type X gypsum board, and insulation, respectively.

4.4.1 Wood Protection

Wood is permitted for use to increase fire resistance of structural wood members and connections and to provide thermal separation.

4.4.1.1 The protection time, t_p , provided by extra wood, using either larger members or added wood layers, is calculated as:

$$t_p = 60 \left(\frac{d_p}{\beta_t} \right)^{1.23} \text{ minutes} \quad \text{(Equation 4.4-1)}$$

Where:

d_p = thickness of the protective layer of wood (inches)

β_t = non-linear char rate constant (in/hr^{0.813})

For a nominal char rate of 1.5 inches/hr, the non-linear char rate is $\beta_t = 1.5 \text{ in/hr}^{0.813}$ and the equation to calculate the protection time, t_p , associated with a protective wood membrane of a

thickness, d , is as follows:

$$t_p = 60 \left(\frac{d_p}{1.5} \right)^{1.23} \text{ minutes} \quad (\text{Equation 4.4-2})$$

Where wood elements are used as a fire barrier and the unexposed face is not in contact with the protected member, the protection time, t_p , associated with char-through of a wood element is as follows:

$$t_p = \left[60 \left(\frac{d_p - 0.6}{1.5} \right)^{1.23} + 17 \right] \text{ minutes for } d_p \geq 0.6 \text{ inches} \quad (\text{Equation 4.4-3a})$$

$$t_p = 60 \left(\frac{d_p}{2.1} \right) \text{ minutes for } d_p < 0.6 \text{ inches} \quad (\text{Equation 4.4-3b})$$

4.4.1.2 Fasteners attaching wood protection do not need to be protected; however, they should be of sufficient length to ensure that the protection stays in place for the required time.

4.4.1.3 The contribution of wood layers to the thermal separation time shall be equal to the sum of protection times assigned to each layer, determined in 4.4.1.1, except that where a single layer of wood is used to provide thermal separation or where the final layer on the unexposed side of the thermal separation is wood, the time assigned to that wood layer, determined in 4.4.1.1, shall be multiplied by 0.85.

4.4.1.4 Where char contraction will cause gaps to form between wood elements that are initially considered to be in contact, detailing shall be provided to ensure that wood elements provide the added fire resistance time or thermal separation time determined in 4.4.1.1 or 4.4.1.2, respectively. The size of gaps can be determined by multiplying the char depth by the char contraction factor as follows:

$$g = C_{CF} a_{char} \quad (\text{Equation 4.4-4})$$

Where:

g = gap created by char contraction, inches

a_{char} = char depth (calculated in 4.1.1.2), inches

C_{CF} = char contraction factor (may be taken as 0.30, per Section 1.5.1)

4.4.1.5 Char contraction at wood member ends and edges results in ignition of wood surfaces in the gaps created by the char contraction. As a result, ignition can be assumed to extend into these gaps a distance that is twice the char depth, $2a_{char}$, or additional detailing shall be provided to prevent charring at these locations. The effects of char contraction may be lessened or mitigated through use of fire-stopping materials such as mineral wool insulation, intumescent tapes and fire sealants. It is up to the designer to determine, in consultation with the fire-stop product manufacturer and the authority having jurisdiction, the applicability of such products and to verify their performance within the assembly by means of test data or other substantiated performance indicators.

4.4.2 Gypsum Board Protection

Fire-rated gypsum board (Type X) is permitted for use to increase fire resistance of wood members and assemblies and to provide thermal separation.

4.4.2.1 The protection time, t_p , provided by each layer of Type X gypsum board is provided in Table 4.4.2.1.

Table 4.4.2.1 Fire Resistance Time for Type X Gypsum Board¹

Protection Description ^{1,2}	Gypsum Board Cover of Members ^{3,4}	Gypsum Board Membrane Protection of Members & Assemblies ^{5,6}		Protection Time, t_p , until Charring of Protected Surface Begins (minutes)
	Maximum Fastener Spacing (inches)	Maximum Framing Spacing (inches)	Maximum Fastener Spacing (inches)	
1/2-inch Type X Gypsum Board	12	16 24	12 8	30 ⁷
5/8-inch Type X Gypsum Board	12	16 24	12 8	40 ^{8,9}

¹ Panel edges of the gypsum board face layer shall be taped and finished with joint compound and fastener heads shall be covered with joint compound.

² Each gypsum board layer shall be attached with fasteners of sufficient length to penetrate the wood element at least 1 inch or be attached to steel channels capable of supporting the weight of the gypsum board.

³ Where multiple layers of gypsum board are required, all adjoining panel edges shall be offset at least 16 inches from those of the adjacent underlying layer and attached with fasteners offset 4 inches in both orthogonal directions from the fasteners in all underlying layers.

⁴ Gypsum board cover attached to wood members shall be installed such that gypsum cover at outside corners overlaps by at least the thickness of the gypsum. For gypsum board cover attached to horizontal wood members (e.g. wood beams), side layers shall be installed first, followed by the bottom layer(s) to ensure that the edges of the side layers are covered.

⁵ At wall-to-ceiling intersections, gypsum board shall be installed such that the ceiling gypsum board is installed first, followed by the wall gypsum board to ensure that the ceiling gypsum board is supported by each layer of the wall gypsum board.

⁶ At wall-to-wall intersections, each layer of gypsum board shall be installed such that the gypsum board on the wall with a greater fire resistance rating is installed first, followed by the gypsum board on the intersecting wall.

⁷ For wood-frame walls with studs spaced 16 inches on center or less, the protection time, t_p , for 1/2" Type X gypsum board with 2-1/4" Type S drywall screws spaced at 7 inches on center or less at panel edges and in panel field shall be permitted to be increased to 33 minutes.

⁸ For wood-frame walls with studs spaced 16 inches on center or less, the protection time, t_p , for 5/8" Type X gypsum board with 2-1/4" Type S drywall screws spaced at 7 inches on center or less at panel edges and in panel field shall be permitted to be increased to 48 minutes.

⁹ For-wood-frame walls with studs spaced 24 inches on center or less, the protection time, t_p , for 5/8" Type X gypsum board with 2-1/4" Type S drywall screws spaced at 8 inches on center or less at panel edges and in panel field shall be permitted to be increased to 44 minutes.

4.4.2.2 Fasteners attaching gypsum board do not need to be protected; however, they should be of sufficient length to ensure that the gypsum board stays in place for the required time. Prescriptive requirements to meet this intent are provided in Table 4.4.2.1 footnotes.

4.4.2.3 The contribution of Type X gypsum board layers to the thermal separation time shall be equal to the sum of protection times assigned to each layer, determined in 4.4.2.1, except where a single layer of Type X gypsum board is used to provide thermal separation or where the final layer on the unexposed side of the thermal separation is Type X gypsum board, the time assigned to that Type X gypsum board layer, determined in 4.4.2.1, shall be multiplied by 0.50.

4.4.2.4 Where gypsum board contraction will cause gaps to form between gypsum board panels that are initially considered to be in contact, detailing shall be provided to ensure that the gypsum board provides the added fire resistance time or thermal separation time determined in 4.4.2.1 or 4.4.2.2, respectively. The effects of gypsum board contraction may be lessened or mitigated through use of fire-stopping materials such as mineral wool insulation, intumescent tapes and fire sealants. It is up to the designer to determine, in consultation with the fire-stop product manufacturer and the authority having jurisdiction, the applicability of such products and to verify their performance within the assembly by means of test data or other substantiated performance indicators.

4.4.3 Insulation

Mineral wool and fiberglass insulation are permitted for use to increase fire resistance of wood members and assemblies, and to provide thermal separation.

4.4.3.1 The protection time, t_p , provided by mineral wool or fiberglass insulation is a function of the protection provided to each wood surface that is protected. Table 4.4.3.1 provides values for two types of insulation. For each wood surface protected by insulation, initiation of charring shall be permitted to be delayed by the time provided in Table 4.4.3.1. For wall assemblies, insulation shall fill the entire study cavity. Protection times in 4.4.3.1 shall not be increased for additional layers of thickness of insulation beyond the tabulated values.

Table 4.4.3.1 Fire Resistance Time for Protected Wood Surfaces

Insulation Description	Minimum Thickness (inches)	Protection Time, t_p, until Charring of Protected Surface Begins (minutes)
Mineral wool insulation (minimum nominal density: 2.5 pcf)	3.5	19
	1.5	17
Fiberglass insulation (minimum R-13)	3.5	3

4.4.3.2 The contribution of insulation layers to the thermal separation time shall be equal to the sum of protection times assigned to each layer, determined in 4.4.3.1.

4.5 Wood Connections

Wood structural connections, including connectors, fasteners and members, shall be protected from fire exposure for the required fire resistance time. Protection of the connection shall be provided by wood, fire-rated gypsum board, other approved materials, or a combination thereof. Fasteners attaching the protection do not need to be protected; however, they should be of sufficient length to ensure that the protection stays in place for the required time.

4.5.1 Connection Protection Performance

Protection of wood structural connections shall be designed to limit the average temperature rise to 250 °F (139 °C), and the maximum temperature rise at any point to 325 °F (181 °C), at the interface between the connection and the protection. Design of the protection shall be in accordance with the thermal separation provisions of 4.4.1.3 for wood protection and 4.4.2.3 for gypsum board protection.

Exception: Connections in assemblies tested in accordance with ASTM E119. For tested assemblies, an option for the preliminary design of the protection would be to limit the average temperature at the interface between the connection and the protection to the charring temperature of wood (approximately 600 °F or 300 °C) using provisions of 4.4.1.1 for wood protection and 4.4.2.1 for gypsum board protection.

4.5.2 Gaps at Ends and Edges

Char contraction at unbonded wood member ends and edges results in ignition of wood surfaces in the gaps at these locations. The penetration of ignition into these gaps is assumed to be twice the char depth, $2a_{char}$. Since ignition occurs when the wood is initially exposed due to char contraction, the elevated temperature zone does not initially extend beyond the point of ignition into the gap; therefore, the char penetration into the gap does not need to be increased by the 1.2 factor required for structural calculations in 4.1.1.4. Protection of connections at ends and edges of wood members shall address this penetration to ensure the provisions of 4.5.1 are met.

4.5.3 Common Details

Example details for commonly used fasteners and connectors in timber framing are shown in Figure 4-3 (Beam to Column Connection Exposed to Fire Where Appearance is a Factor), Figure 4-4 (Beam to Girder - Concealed Connection), Figure 4-5 (Column Connections - Covered). The thickness of protection required to provide thermal separation for Figures 4-3, 4-4, and 4-5 was determined to be $d_p = 1.14a_{char}$ using the provisions of 4.5.1. In these Figures, note that the protection is inherent to the wood member. When added protection is provided by additional wood members or gypsum board, the protection time of each layer must be calculated separately and combined using the provisions from 4.4. The depth of the protection at member ends to address char contraction on Figure 4-4 was determined to be $d_p = 2a_{char}$ using the provisions of 4.5.2.

Required Wood Protection (for required fire resistance rating (FRR) in hours):

From Equation 4.4-2 and Section 4.4.1.3:

$$t_p = 0.85 \left[60 \left(\frac{d_p}{1.5} \right)^{1.23} \right] = 60(FRR) \quad \text{(Equation 4.5-1)}$$

$$d_p = 1.5(FRR/0.85)^{0.813} \text{ inches} \quad \text{(Equation 4.5-2)}$$

From Equation 4.1-2, determine a_{char} :

$$a_{char} = 1.5t^{0.813} = 1.5(FRR)^{0.813} \quad \text{(Equation 4.5-3)}$$

$$FRR = (a_{char}/1.5)^{1.23} \text{ hours} \quad \text{(Equation 4.5-4)}$$

Combining Equation 4.5-2 and 4.5-4:

$$d_p = 1.5[(a_{char}/1.5)^{1.23}/0.85]^{0.813} = 1.14a_{char} \text{ inches} \quad \text{(Equation 4.5-5)}$$

Char Contraction at Member Ends:

$$d_p = 2a_{char} \text{ inches} \quad \text{(Equation 4.5-6)}$$

Figure 4-3 Beam to Column Connection

Beam and Column Exposed to Fire Where Appearance is a Factor

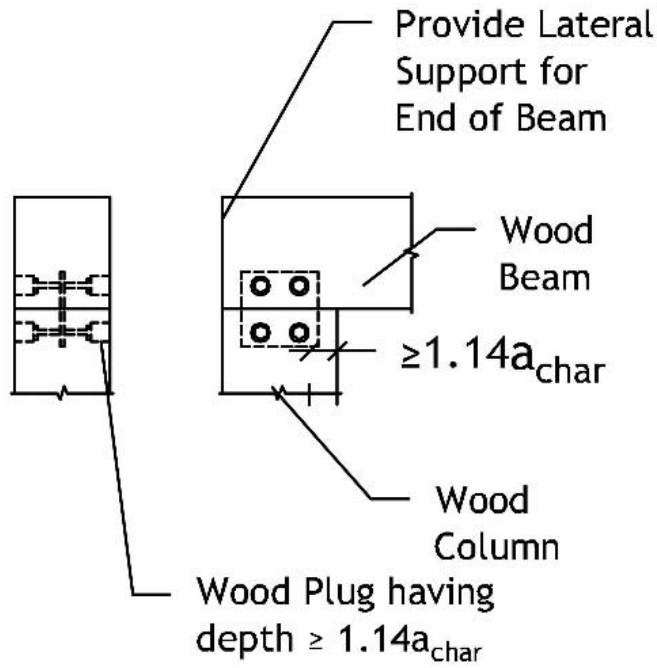

Figure 4-4 Beam to Girder - Concealed Connection

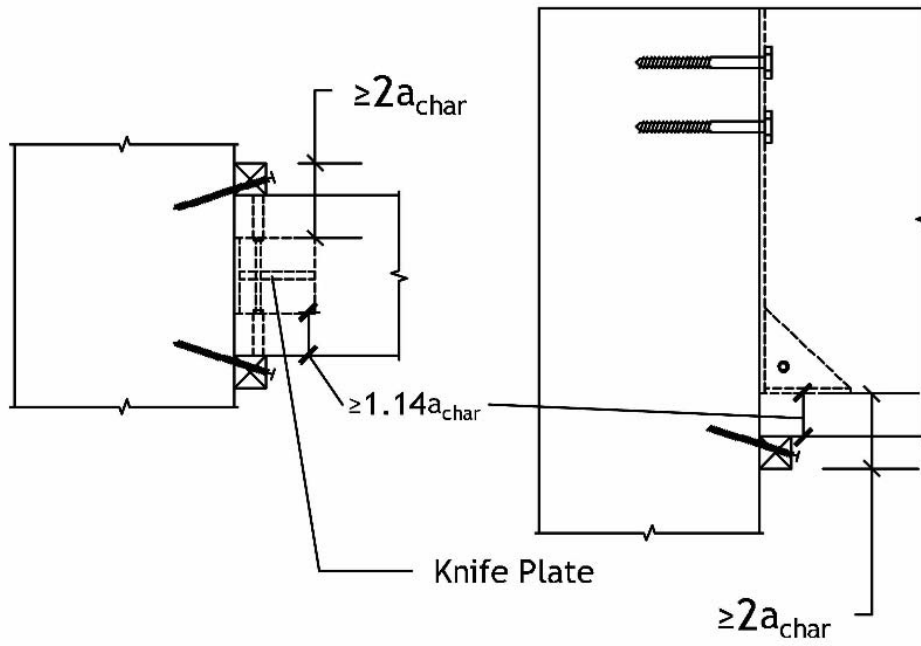
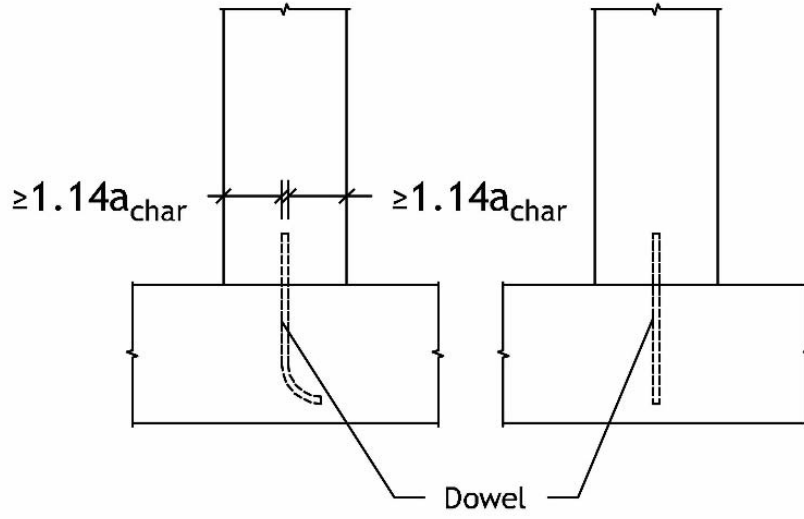

Figure 4-5 Column Connections - Covered



Part V: Application Guidelines and Design Examples

5.1 Application Guidelines for Wood Members

For given member sizes, different fire resistance times can be achieved by varying the percent of maximum design load applied to the member. Examples of the relationship between section size, load ratio, and fire resistance time are based on Sections 4.1 and 4.2. Tabulated design aids have been developed for some common design cases and are provided in Appendix A. Examples are also provided to demonstrate how to combine protection designed per Section 4.4 with exposed wood member designs per Section 4.1 and 4.2. Also provided are examples of protected wood connections.

Example 1: Exposed Beam - Allowable Stress Design

Simply-supported Douglas fir glulam beams span $L=18$ ft, and are spaced at $s=6$ ft. The design loads are $q_{live}=100$ psf and $q_{dead}=25$ psf. Timber decking nailed to the compression edge of the beams provides lateral bracing for at least the same fire resistance time as the beams (i.e. $C_L = 1.0$). Calculate the required section dimensions for a 1-hour structural fire resistance time when subjected to an ASTM E119 fire exposure.

For the structural design of the wood beam, calculate the maximum induced moment.

Calculate beam load:

$$W_{load} = s (q_{dead} + q_{live}) = (6)(25+100) = 750 \text{ plf}$$

Calculate maximum induced moment:

$$M_{max} = W_{load} L^2 / 8 = (750)(18^2)/8 = 30,375 \text{ ft-lb}$$

Calculate maximum induced shear:

$$V_{max} = W_{load} L / 2 = (750)(18)/2 = 6,750 \text{ lb}$$

Select a $6\frac{3}{4}$ " x $13\frac{1}{2}$ " 24F-V4 Douglas-fir glulam beam with a tabulated bending stress, F_b , equal to 2400 psi and a tabulated shear stress, F_v , equal to 265 psi.

Calculate beam section modulus:

$$S_s = bd^2/6 = (6.75)(13.5)^2/6 = 205 \text{ in}^3$$

Calculate the adjusted allowable bending stress (assuming $C_D=1.0$: $C_M=1.0$: $C_t=1.0$: $C_L=1.0$: $C_V=0.98$)

$$F'_b = F_b (C_D)(C_M)(C_t)(\text{lesser of } C_L \text{ or } C_V) = 2400 (1.0)(1.0)(1.0)(0.98) = 2343 \text{ psi} \quad (\text{NDS 5.3.1})$$

Calculate design resisting moment:

$$M_s' = F'_b S_s = (2343)(205.0)/12 = 40,032 \text{ ft-lb}$$

Structural Bending Check: $M_s' \geq M_{max}$ **40,032 ft-lb > 30,375 ft-lb** ✓

Calculate beam shear area:

$$A_s = bd = (6.75)(13.5) = 91.1 \text{ in}^2$$

Calculate the adjusted allowable shear stress (assuming $C_D=1.0$: $C_M=1.0$: $C_t=1.0$)

$$F'_v = F_v (C_D)(C_M)(C_t) = 265 (1.0)(1.0)(1.0) = 265 \text{ psi} \quad (\text{NDS 5.3.1})$$

Calculate design resisting shear:

$$V_s' = 2/3 F'_v A_s = 2/3(265)(91.1) = 16,094 \text{ lb}$$

Structural Shear Check: $V_s' \geq V_{max}$ **16,094 lb > 6,750 lb** ✓

For the fire design of the wood beam, mass loss due to charring is conservatively neglected so the loading is unchanged. Therefore, the maximum induced moment is unchanged. The fire resistance must be calculated.

Determine the effective char depth, a_{eff} :

$$a_{eff} = 1.8 \text{ inches} \quad (\text{NDS Table 16.2.1A})$$

Calculate section modulus for a beam exposed on three-sides:

$$S_f = (b-2a_{eff})(d-a_{eff})^2/6 = (6.75-3.6)(13.5-1.8)^2/6 = 71.9 \text{ in}^3 \quad (\text{NDS 16.2.1})$$

Calculate the adjusted bending strength (assuming $C_D=N/A$: $C_M=N/A$: $C_t=N/A$: $C_L=1.0$: $C_V=0.98$)

$$F_{b,f} = (2.85) F_b (\text{lesser of } C_L \text{ or } C_V) = 2.85(2400)(0.98) = 6703 \text{ psi} \quad (\text{NDS 16.2.2})$$

Calculate the resisting moment:

$$M_f' = F_{b,f} S_f = (6703)(71.9)/12 = 40,145 \text{ ft-lb} \quad (\text{NDS 16.2.2})$$

Fire Bending Check: $M_f' \geq M_{max}$ **40,145 ft-lb > 30,375 ft-lb** \checkmark
 Calculate shear area for a beam exposed on three-sides:
 $A_f = (b-2a_{eff})(d-a_{eff}) = (6.75-3.6)(13.5-1.8) = 36.9 \text{ in}^2$ (NDS 16.2.1)

Calculate the adjusted shear strength (assuming $C_D=N/A$: $C_M=N/A$: $C_t=N/A$)
 $F_{v',f} = (2.75) F_{v,f} = 2.75(265) = 729 \text{ psi}$ (Table 4.1.2)

Calculate the resisting shear:
 $V_f' = 2/3 F_{v',f} A_f = 2/3(729)(36.9) = 17,933 \text{ lb}$ (NDS 16.2.2)

Fire Shear Check: $V_f' \geq V_{max}$ **17,933 lb > 6,750 lb** \checkmark

Simplified alternative approach (using design aid in Appendix A):

Select the maximum design load ratio limit from Appendix A, Table 1B or calculate using the following equation:

$$R_s = \frac{2.85 S_f}{S_s C_D C_M C_t} = \frac{(2.85)(71.9)}{(205)(1.0)(1.0)(1.0)} = 1.0$$

Fire Check: $M_s' R_s \geq M_{max}$ **(40,032 ft-lb)(1.00) > 30,375 ft-lb** \checkmark

For this simple case, where bending moment in one axis is being checked, the design load ratio limit from Appendix A Table A1(1-hr), $R_s = 1.00$, need only be greater than the structural design load ratio, $r_s = M_{max} / M_s' = 30,375 / 40,032 = 0.76$.

Example 2: Exposed Column - Allowable Stress Design

A Southern pine glulam column with an effective column length, $L_e=168$ inches. The design loads are $P_{snow}=16,000$ lb and $P_{dead}=6,000$ lb. Calculate the required section dimensions for a 1-hour structural fire resistance time when subjected to an ASTM E119 fire exposure.

For the structural design of the wood column, calculate the maximum induced compression stress, f_c .

Calculate column load:

$$P_{load} = P_{dead} + P_{snow} = 6,000 + 16,000 = 22,000 \text{ lb}$$

Select an $8\frac{1}{2}'' \times 9\frac{5}{8}''$ Combination #48 Southern pine glulam column with a tabulated compression parallel-to-grain stress, F_c , equal to 2200 psi and a tabulated minimum modulus of elasticity, E_{min} , equal to 900,000 psi.

Calculate column area:

$$A_s = bd = (9.625)(8.5) = 81.81 \text{ in}^2$$

$$I_s = bd^3/12 = (9.625)(8.5)^3/12 = 492.6 \text{ in}^4$$

Calculate the adjusted allowable compression stress (assuming $C_D=1.15$: $C_M=1.0$: $C_t=1.0$):

$$E_{min}' = E_{min} (C_M)(C_t) = 900,000 (1.0)(1.0) = 900,000 \text{ psi} \quad (\text{NDS 5.3.1})$$

$$L_e/d_1 = 168/9.625=17.5 : L_e/d_2 = 168/8.5=19.7 : \text{Maximum } L_e/d = 19.7 \quad (\text{NDS 3.7.1.3})$$

$$F_{cE} = 0.822 E_{min}' / (L_e/d)^2 = 0.822 (900,000) / (19.7)^2 = 1894 \text{ psi} \quad (\text{NDS 3.7.1.5})$$

$$F_c^* = F_c (C_D)(C_M)(C_t) = 2200 (1.15)(1.0)(1.0) = 2530 \text{ psi} \quad (\text{NDS 3.7.1.5})$$

$$c = 0.9 \text{ for glued laminated timbers} \quad (\text{NDS 3.7.1.5})$$

$$\alpha_c = F_{cE}/F_c^* = 1894/2530 = 0.7485$$

$$C_p = \frac{1+\alpha_c}{2c} - \sqrt{\left(\frac{1+\alpha_c}{2c}\right)^2 - \frac{\alpha_c}{c}} = \frac{1+0.7485}{2(0.9)} - \sqrt{\left(\frac{1+0.7485}{2(0.9)}\right)^2 - \frac{0.7485}{0.9}} = 0.6369 \quad (\text{NDS 3.7.1.5})$$

$$F_c' = F_c^* C_p = 2530 (0.6368) = 1611 \text{ psi} \quad (\text{NDS 5.3.1})$$

Calculate the resisting column compression capacity:

$$P'_s = F_c' A_s = (1611)(81.81) = 131,819 \text{ lb}$$

Structural Check: $P'_s \geq P_{load}$ **131,819 lb > 22,000 lb** \checkmark

For the fire design of the wood column, mass loss due to charring is conservatively neglected so the loading is unchanged. Therefore, the total load is unchanged. The fire resistance must be calculated.

Determine the effective char depth, a_{eff} .

$$a_{eff} = 1.8 \text{ inches} \quad (\text{NDS Table 16.2.1A})$$

Calculate column area, A , and moment of inertia, I , for column exposed on four-sides:

$$A_f = (b-2a_{eff})(d-2a_{eff}) = (9.625-3.6)(8.5-3.6) = 29.52 \text{ in}^2$$

$$I_f = (b-2a_{eff})(d-2a_{eff})^3/12 = (9.625-3.6)(8.5-3.6)^3/12 = 59.07 \text{ in}^4$$

Calculate the adjusted compression strength (assuming $C_D=N/A$: $C_M=N/A$: $C_t=N/A$):

$$L_e/d_1 = 168/(9.625-3.6)=27.9 : L_e/d_2 = 168/(8.5-3.6)=34.3 : \text{Maximum } L_e/d = 34.3 \quad (\text{NDS 3.7.1.3})$$

$$F_{cE,f} = (2.03) 0.822 E' / (L_e/d)^2 = (2.03)(0.822)(900,000) / (34.3)^2 = 1278 \text{ psi} \quad (\text{NDS 16.2.2})$$

$$F_{c,f}^* = (2.58) F_c = (2.58)(2200) = 5676 \text{ psi} \quad (\text{NDS 16.2.2})$$

$$\alpha_c = F_{cE,f}/F_{c,f}^* = 1278/5676 = 0.2251$$

$$C_{p,f} = \frac{1 + 0.2251}{2(0.9)} - \sqrt{\left(\frac{1 + 0.2251}{2(0.9)}\right)^2 - \frac{0.2251}{0.9}} = 0.2189$$

$$F_{c,f}' = 5676 (0.2189) = 1243 \text{ psi}$$

Calculate the resisting column compression capacity:

$$P'_f = F_{c,f} A_f = (1243)(29.52) = 36,689 \text{ lb}$$

Fire Check: $P'_f \geq P_{load}$ **36,689 lb > 22,000 lb** ✓

Simplified alternative approach (using design aid in Appendix A):

Calculate the maximum design load ratio using R_{s1} and R_{s2} terms from Appendix A, Table 5A:

$$R_{s1} = 0.25 : R_{s2} = 1.09$$

$$R_s = R_{s1} R_{s2} = (0.25)(1.09) = 0.27 \leq 1.0 \quad (\text{use } 0.27)$$

Fire Check: $P'_s R_s \geq P_{load}$ **(131,819 lb)(0.27) = 35,600 lb > 22,000 lb** ✓

For this simple case where only concentrically-loaded compression is being checked, the design load ratio limit from Appendix A Table A2(1-hr), $R_s = 0.27$, need only be greater than the structural design load ratio, $r_s = P_{load} / P'_s = 22,000/131,819 = 0.17$.

Note: While it does not make a difference in the final result of this example, the simplified alternative method will usually yield a slightly more conservative value for the fire design check as illustrated in this example by the difference between 36,689 lb and 35,600 lb. This is because the R_{s1} and R_{s2} values are derived based on the most conservative result using $c = 0.8$ and $c = 0.9$. This allows the simplified alternative method to be used for sawn lumber, structural glued laminated timber, and structural composite lumber.

Example 3: Exposed Tension Member - Allowable Stress Design

Sawn Hem-Fir timbers used as heavy timber truss bottom chords with an unbraced length $L_u = 20$ ft. The total design tension load from a roof live and dead load are $P_{load} = 2,000$ lb. The bending load due to the dead load of the timber will be determined based on timber size. Calculate the required section dimensions for a 1-hour structural fire resistance time when subjected to an ASTM E119 fire exposure.

Select a nominal 6x6 (5½" x 5½") Hem-Fir #2 grade timber with a tabulated bending stress, F_b , equal to 575 psi, a tabulated tension stress, F_t , equal to 375 psi, and a tabulated minimum modulus of elasticity, E_{min} , equal to 400,000 psi.

Calculate timber area:

$$A_s = bd = (5.5)(5.5) = 30.25 \text{ in}^2$$

$$S_s = bd^2/6 = (5.5)(5.5)^2/6 = 27.73 \text{ in}^3$$

Calculate the maximum induced tension stress, f_t :

$$P_{load} = 2,000 \text{ lb}$$

$$f_t = P_{load} / A_s = 2000/30.25 = 66.1 \text{ psi}$$

Calculate the adjusted allowable tension stress (assuming $C_D=1.25$: $C_M=1.0$: $C_t=1.0$):

$$F_t' = F_t (C_D)(C_M)(C_t) = 375 (1.25)(1.0)(1.0) = 469 \text{ psi} \quad (\text{NDS 4.3.1})$$

The density of the timber is estimated as 30 pcf:

$$w_{load} = (30 \text{ pcf} / 144)(30.25) = 6.3 \text{ plf}$$

Calculate maximum induced bending stress, f_b :

$$M_{max} = w_{load} L^2 / 8 = (6.3)(20^2)/8 = 315 \text{ ft-lb} = 3,780 \text{ in-lb}$$

$$f_b = M_{max} / S_s = 3780/27.73 = 136 \text{ psi}$$

Calculate the adjusted allowable bending stress (assuming $C_D=1.25$: $C_M=1.0$: $C_t=1.0$):

$$F_b^* = F_b (C_D)(C_M)(C_t) = 575 (1.25)(1.0)(1.0) = 719 \text{ psi} \quad (\text{NDS 3.3.3.8})$$

Since $b=d$, $C_L = 1.0$ (NDS 3.3.3.1)

$$F_b' = F_b^* C_L = 719 (1.0) = 719 \text{ psi} \quad (\text{NDS 4.3.1})$$

Structural Check:	$F_t' \geq f_t$	469 psi \geq 66 psi	✓
Structural Check:	$F_b' \geq f_b$	719 psi \geq 136 psi	✓
Structural Check:	$f_t / F_t' + f_b / F_b' \leq 1.0$	66/469 + 136/719 = 0.33 \leq 1.0	✓

For the fire design of the timber tension member, the tension load is unchanged; however, the dead load of the timber has changed.

Determine the effective char depth, a_{eff} :

$$a_{eff} = 1.8 \text{ inches} \quad (\text{NDS Table 16.2.1A})$$

Calculate effective section properties for member exposed on four-sides:

$$A_f = (b-2a_{eff})(d-2a_{eff}) = (5.5-3.6)(5.5-3.6) = 3.61 \text{ in}^2$$

$$S_f = (b-2a_{eff})(d-2a_{eff})^2/6 = (5.5-3.6)(5.5-3.6)^2/6 = 1.14 \text{ in}^3$$

Calculate the maximum induced tension stress, f_t :

$$P_{load} = 2,000 \text{ lb}$$

$$f_t = P_{load} / A_s = 2000/3.61 = 554 \text{ psi}$$

Calculate the adjusted tension strength (assuming $C_D=N/A$: $C_M=N/A$: $C_t=N/A$):

$$F_{t,t}' = (2.85) F_t = 2.85 (375) = 1069 \text{ psi} \quad (\text{NDS 16.2.2})$$

The initial weight of the timber was estimated to be 6.3 plf; however, the volume of the beam changed due to charring. The weight of the char layer is assumed to be negligible, but the actual char depth is used rather than the effective char depth:

$$w_{load} = (30 / 144) (b-2(a_{char}))(d-2(a_{char})) = (30 / 144) (5.5-3.0)(5.5-3.0) = 1.3 \text{ plf}$$

Calculate maximum induced bending stress, f_b :

$$M_{max} = w_{load} L^2 / 8 = (1.3)(20^2)/8 = 65 \text{ ft-lb} = 780 \text{ in-lb}$$

$$f_b = M_{max} / S_s = 780/1.14 = 683 \text{ psi}$$

Calculate the adjusted bending strength (assuming $C_D=N/A$: $C_M=N/A$: $C_t=N/A$):

$$F_{b,f}^* = (2.85) F_b = (2.85)(575) = 1639 \text{ psi}$$

(NDS 3.3.3.8)

$$\text{Since } (b-2a_{eff}) = (d-2a_{eff}), C_L = 1.0$$

(NDS 3.3.3.1)

$$F_{b,f}' = F_b^* C_L = 1639 (1.0) = 1639 \text{ psi}$$

(NDS 4.3.1)

Fire Check:	$F_{t,f}' \geq f_t$	1069 psi \geq 554 psi	✓
Fire Check:	$F_{b,f}' \geq f_b$	1639 psi \geq 683 psi	✓
Fire Check:	$f_t / F_{t,f}' + f_b / F_{b,f}' \leq 1.0$	554/1069 + 683/1639 = 0.93 \leq 1.0	✓

Example 4: Exposed Decking - Allowable Stress Design

Decking spans $L=6'$. A single layer of $3/4"$ sheathing is installed over the decking. The design loads are $q_{live}=40$ psf and $q_{dead}=10$ psf. Using tongue-and-groove and square-edged timber decking, calculate the required decking depth for a 1-hour structural fire resistance time when subjected to an ASTM E119 fire exposure.

Tongue-and-groove decking:

Calculate deck load on a one-foot-wide strip:

$$W_{load} = B(q_{dead}+q_{live}) = (1 \text{ ft})(50 \text{ psf}) = 50 \text{ plf}$$

Calculate maximum induced moment:

$$M_{max} = W_{load} L^2 / 8 = (50)(6^2)/8 = 225 \text{ ft-lb}$$

Select nominal 3x6 ($2\frac{1}{2}" \times 5\frac{1}{2}"$) Hem-Fir tongue-and-groove Commercial decking with a tabulated repetitive member bending stress, $F_b(C_r)$, equal to 1350 psi.

Calculate the section modulus of a one-foot-wide strip:

$$S_s = bd^2/6 = (12)(2.5)^2/6 = 12.5 \text{ in}^3$$

Calculate the adjusted allowable bending stress (assuming $C_D=1.0$: $C_M=1.0$: $C_t=1.0$: $C_F=1.04$):

$$F_b(C_r) = 1350 \text{ psi}$$

$$F_{b,s} = F_b(C_r) (C_D)(C_M)(C_t)(C_F) = 1350 (1.0)(1.0)(1.0)(1.04) = 1404 \text{ psi} \quad (\text{NDS 4.3.1})$$

Calculate resisting moment:

$$M_s' = F_{b,s} S_s = (1404)(12.5)/12 = 1463 \text{ ft-lb}$$

Structural Check: $M_s' \geq M_{max}$ **1463 ft-lb > 225 ft-lb** √

For the fire design of the timber deck, mass loss due to charring is conservatively neglected so the loading is unchanged. Therefore, the maximum induced moment is unchanged. The fire resistance must be calculated.

Determine the effective char depth, a_{eff} :

$$a_{eff} = 1.8 \text{ inches (NDS Table 16.2.1A)}$$

Calculate the section modulus of a one-foot-wide strip exposed on the bottom surface:

$$S_f = (b)(d-a_{eff})^2/6 = (12)(2.5-1.8)^2/6 = 0.98 \text{ in}^3$$

Calculate the adjusted allowable bending stress (assuming $C_D=N/A$: $C_M=N/A$: $C_t=N/A$: $C_F=1.04$):

$$F_{b,f} = (2.85) F_b(C_r) (C_F) = 2.85(1350)(1.04) = 4001 \text{ psi}$$

Calculate resisting moment:

$$M_f' = F_{b,f} S_f = (4001)(0.98)/12 = 327 \text{ ft-lb} \quad (\text{NDS 16.2.2})$$

Fire Check: $M_f' \geq M_{max}$ **327 ft-lb > 225 ft-lb** √

Simplified alternative approach (using design aid in Appendix A):

Select the maximum design load ratio limit from Appendix A, Table 9 or calculate using the following equation:

$$R_s = \frac{2.85 S_f}{S_s C_D C_M C_t} = \frac{(2.85)(0.98)}{(12.5)(1.0)(1.0)(1.0)} = 0.22$$

Fire Check: $M_s'R_s \geq M_{max}$ **(1463 ft-lb)(0.22) = 322 > 225 ft-lb** √

For this simple case where only bending moment in one axis is being checked, the design load ratio limit from Appendix A Table A3.2, $R_s = 0.22$, need only be greater than the structural design load ratio, $r_s = M_{max}/M' = 225/1463 = 0.15$.

Square-edged decking:

Assume a board width of 5.5 inches

Calculate deck load:

$$W_{load} = B(q_{dead} + q_{live}) = (5.5 \text{ in} / 12 \text{ in/ft})(50 \text{ psf}) = 22.9 \text{ plf}$$

Calculate maximum induced moment on each member:

$$M_{max} = W_{load} L^2 / 8 = (22.9)(6^2)/8 = 103 \text{ ft-lb}$$

Select nominal 3x6 (2½" x 5½") Hem-Fir square-edged Commercial decking with a tabulated repetitive member bending stress, $F_b(C_r)$, equal to 1350 psi.

Calculate the section modulus of each member:

$$S_s = bd^2/6 = (5.5)(2.5)^2/6 = 5.73 \text{ in}^3$$

Calculate the adjusted allowable bending stress (assuming $C_D=1.0$: $C_M=1.0$: $C_t=1.0$: $C_F=1.04$):

$$F'_{b,s} = F_b(C_r)(C_D)(C_M)(C_t)(C_F) = 1350(1.0)(1.0)(1.0)(1.04) = 1404 \text{ psi} \quad (\text{NDS 4.3.1})$$

Calculate resisting moment:

$$M_{s'} = F'_{b,s} S_s = (1404)(5.73)/12 = 670 \text{ ft-lb}$$

Structural Check: $M_{s'} \geq M_{max}$ **670 ft-lb > 103 ft-lb** ✓

For the fire design of the timber deck, mass loss due to charring is conservatively neglected so the loading is unchanged. Therefore, the maximum induced moment is unchanged. The fire resistance must be calculated.

Determine the effective char depth, a_{eff} :

$$a_{eff} = 1.8 \text{ inches} \quad (\text{NDS Table 16.2.1A})$$

Calculate the section modulus of a member, exposed fully on the bottom surface, with 33% of the effective char rate on the butt-jointed sides:

$$S_f = (b-2(a_{eff}/3))(d-a_{eff})^2/6 = (5.5-2(1.8/3))(2.5-1.8)^2/6 = 0.351 \text{ in}^3$$

Calculate the adjusted allowable bending stress (assuming $C_D=N/A$: $C_M=N/A$: $C_t=N/A$: $C_F=1.04$):

$$F'_{b,f} = (2.85) F_b(C_r)(C_F) = 2.85(1350)(1.04) = 4001 \text{ psi}$$

Calculate resisting moment:

$$M_{f'} = F'_{b,f} S_f = (4001)(0.351)/12 = 117 \text{ ft-lb} \quad (\text{NDS 16.2.2})$$

Fire Check: $M_{f'} \geq M_{max}$ **117 ft-lb > 103 ft-lb** ✓

Simplified alternative approach (using design aid in Appendix A):

Select the maximum design load ratio limit from Appendix A, Table 9 or calculate using the following equation:

$$R_s = \frac{2.85 S_f}{S_s C_D C_M C_t} = \frac{(2.85)(0.351)}{(5.73)(1.0)(1.0)(1.0)} = 0.18$$

Fire Check:

$$M_s'R_s \geq M_{\max} \quad (670 \text{ ft-lb})(0.18) = 120 > 103 \text{ ft-lb}$$

✓

For this simple case where only bending moment in one axis is being checked, the design load ratio limit from Appendix A Table A3.1 $R_s = 0.18$, need only be greater than the structural design load ratio, $r_s = M_{\max}/M' = 225/1463 = 0.15$.

Note: Thermal separation and burn-through are not covered in this method for decking.

Example 5: Exposed CLT Floor - Allowable Stress Design

Simply-supported cross-laminated timber (CLT) floor spanning L=18 ft in the strong-axis direction. The design loads are $q_{live}=80$ psf and $q_{dead}=30$ psf including estimated self-weight of the CLT panel. Floor decking, nailed to the unexposed face of CLT panel, is spaced to restrict hot gases from venting through half-lap joints at edges of CLT panel sections. Calculate the required section dimensions for a 1-hour structural fire resistance time when subjected to an ASTM E119 fire exposure.

For the structural design of the CLT panel, calculate the maximum induced moment.

Calculate panel load (per foot of width):

$$W_{load} = (q_{dead} + q_{live}) = (30 \text{ psf} + 80 \text{ psf})(1 \text{ ft width}) = 110 \text{ plf/ft of width}$$

Calculate maximum induced moment (per foot of width):

$$M_{max} = W_{load} L^2 / 8 = (110)(18^2)/8 = 4,455 \text{ ft-lb/ft of width}$$

From PRG 320, select a 5-ply CLT floor panel made from 1-3/8 in x 3-1/2 in. lumber boards (CLT thickness of 6-7/8 inches). For CLT grade V2, tabulated properties are:

$$\text{Bending moment, } F_b S_{eff,0} = 4,675 \text{ ft-lb/ft of width} \quad (\text{PRG 320 Annex A, Table A2})$$

Calculate the allowable design moment (assuming $C_D=1.0$: $C_M=1.0$: $C_t=1.0$: $C_L=1.0$)

$$M_s' = F_b(S_{eff})(C_D)(C_M)(C_t)(C_L) = 4,675 (1.0)(1.0)(1.0) = 4,675 \text{ ft-lb/ft of width} \quad (\text{NDS 10.3.1})$$

Structural Check: $M_s' \geq M_{max}$ **4,675 ft-lb/ft > 4,455 ft-lb/ft** ✓

(note: serviceability check is not performed to simplify the design example, but should be done in typical structural design).

For the fire design of the CLT panel, mass loss due to charring is conservatively neglected so the loading is unchanged. Therefore, the maximum induced moment is unchanged. The fire resistance must be calculated.

Determine the effective char depth, a_{eff} :

$$a_{eff} = 1.9 \text{ inches} \quad (\text{NDS Table 16.2.1B})$$

In this example, the effective char depth, a_{eff} , has penetrated through the first face lamination and partially into the second lamination. The contribution of the partially charred cross-ply is neglected and the resisting moment is calculated using the tabulated bending moment for a 3-ply CLT where $F_b S_{eff,0}$, equals 2,030 ft-lb/ft of width.

Calculate the resisting moment (assuming $C_D=N/A$: $C_M=N/A$: $C_t=N/A$: $C_L=1.0$)

$$M_f' = (2.85) F_b(S_{eff})(C_L) = 2.85(2,030)(1.0) = 5,785 \text{ ft-lb/ft of width} \quad (\text{NDS 16.2.2})$$

Fire Check: $M_f' \geq M_{max}$ **5,785 ft-lb/ft > 4,455 ft-lb/ft** ✓

Thermal Separation:

ASTM E119 also requires floor assemblies to be checked for thermal separation wherein transmission of heat through the test specimen during the fire exposure period does not raise the average temperature on the unexposed surface more than 250°F (139°C) above its initial temperature. For CLT, char is assumed to fall off when charring reaches the glueline, therefore the contribution of each layer to thermal separation time is considered separately. Except for the final layer, the estimated contribution of each CLT layer to the thermal separation time is equal to the thermal protection time calculated in accordance with Equation 4.4-2 in 4.4.1.1:

$$t_p = 60 \left(\frac{d_p}{1.5} \right)^{1.23} = 60 \left(\frac{1.375}{1.5} \right)^{1.23} = 54 \text{ minutes}$$

If the CLT is used as an unbacked fire barrier, the estimated time to burn-through on the last layer, t_{bt} , is calculated using Equation 4.4-3a in Section 4.4.1.1:

$$t_{bt} = 60 \left(\frac{d_p - 0.6}{1.5} \right)^{1.23} + 17 = 60 \left(\frac{1.375 - 0.6}{1.5} \right)^{1.23} + 17 = 44 \text{ minutes}$$

From Section 4.4.1.3, the time assigned for thermal separation, t_{ts} , is calculated as:

$$t_{ts} = 4 * 54 + 0.85(44) = 253 \text{ minutes}$$

Thermal Separation Check: $t_{ts} \geq \text{FRR}$ **253 minutes > 60 minutes** ✓

Example 6: Exposed CLT Wall - Allowable Stress Design

Cross-laminated timber (CLT) wall with an unbraced height of $L=120$ inches and loaded in compression in the strong-axis direction. The design loads are $w_{live}=14,000$ plf and $w_{dead}=6,150$ plf including estimated self-weight of the CLT panel. Walls above are supported on a CLT floor slab and aligned with a CLT wall below. Sealing of wall joints with fire-rated caulk restricts hot gases from venting through half-lap joints at edges of CLT panel sections. Calculate the required section dimensions for a 2-hr structural fire resistance time when subjected to an ASTM E119 fire exposure.

Calculate column load:

$$P_{load} = P_{dead} + P_{snow} = 6,150 \text{ plf} + 14,000 \text{ plf} = 20,150 \text{ lb/foot of width.}$$

From PRG 320, select a 7-ply CLT panel made from 1-3/8 in x 3-1/2 in. lumber boards (CLT thickness of 9-5/8 inches). For CLT grade E1, tabulated properties are:

Reference compression stress, $F_{c,0} = 1800$ psi	(PRG 320 Annex A, Table A1)
Reference bending moment, $F_b S_{eff,0} = 18,375$ ft-lb/ft of width	(PRG 320 Annex A, Table A2)
Reference bending stiffness, $E I_{eff,0} = 1,089 \times 10^6$ lb-in ² /ft of width	(PRG 320 Annex A, Table A2)
Reference shear stiffness, $G A_{eff,0} = 1.4 \times 10^6$ lb/ft of width	(PRG 320 Annex A, Table A2)

Calculate the effective wall compression capacity:

$$A_{parallel} = bd \text{ of strong axis plies} = 4(12)(1.375) = 66 \text{ in}^2/\text{ft of width} \quad (\text{NDS 10.3.1})$$

$$P_c = F_{c,0}(A_{parallel}) = (1800)(66) = 118,800 \text{ lb/ft of width} \quad (\text{NDS 10.3.1})$$

Calculate the apparent wall buckling capacity:

Using NDS Equation 10.4-1, the value for $(EI)_{app}$ can be calculated. Since PRG-320 assumes that $E/G = 16$ for CLT, NDS Equation 10.4-1 can be rewritten as:

$$(EI)_{app} = \frac{EI_{eff}}{1 + \frac{K_s EI_{eff}}{G A_{eff} L^2}}$$

For pinned-pinned column buckling, $K_s=11.8$; therefore:

$$(EI)_{app} = \frac{1,089 \times 10^6}{1 + \frac{(11.8)(1,089 \times 10^6)}{(1.4 \times 10^6)(120)^2}} = 665 \times 10^6 \text{ lb/in}^2/\text{ft of width}$$

To estimate $(EI)_{app-min}$ the value for $(EI)_{app}$ is adjusted per provisions of NDS Appendix H and the coefficient of variation of 0.10 from PRG-320:

$$(EI)_{app-min} = (665 \times 10^6)(1 - 1.645(0.10))(1.03)/1.66 = 345 \times 10^6 \text{ lb/in}^2/\text{ft of width} \quad (\text{NDS 10.3.1})$$

Calculate the adjusted allowable column capacity (assuming $C_D=1.0$: $C_M=1.0$: $C_t=1.0$):

$$(EI)_{app-min}' = (EI)_{app-min} (C_M)(C_t) = 345 \times 10^6 (1.0)(1.0) = 345 \times 10^6 \text{ lb/in}^2/\text{ft of width} \quad (\text{NDS 10.3.1})$$

Using the general form of the Euler buckling equation:

$$P_{cE} = \frac{\pi^2 (EI)_{app-min}}{L^2} = \frac{\pi^2 (345 \times 10^6)}{(120)^2} = 236,500 \text{ lb per ft of width} \quad (\text{NDS C3.7.1.5})$$

$$P_c^* = P_c (C_D)(C_M)(C_t) = 118,800 (1.0)(1.0)(1.0) = 118,800 \text{ lb/ft of width} \quad (\text{NDS C3.7.1.5})$$

Use $c = 0.9$ for CLT

$$(\text{NDS C3.7.1.5})$$

$$\alpha_c = P_{cE}/P_c^* = 236,500/118,800 = 1.991$$

$$C_p = \frac{1+\alpha_c}{2c} - \sqrt{\left(\frac{1+\alpha_c}{2c}\right)^2 - \frac{\alpha_c}{c}} = \frac{1+1.991}{2(0.9)} - \sqrt{\left(\frac{1+1.991}{2(0.9)}\right)^2 - \frac{1.991}{0.9}} = 0.9208 \quad (\text{NDS C3.7.1.5})$$

$$P'_s = P_c^* C_p = 118,800 (0.9208) = 109,400 \text{ lb/ft of width} \quad (\text{NDS C.3.7.1.5})$$

Structural Check: $P'_s \geq P_{\text{load}}$ **109,400 lb/ft > 20,150 lb/ft** \checkmark

For the fire design of the CLT wall, mass loss due to charring is conservatively neglected so the loading is unchanged. Therefore, the total load is unchanged. The fire resistance must be calculated.

Determine the effective char depth, a_{eff} .

$$a_{\text{eff}} = 3.8 \text{ inches} \quad (\text{NDS Table 16.2.1B})$$

Calculation of the actual $(EI)_{\text{app}}$ and $(EI)_{\text{app-min}}$ as a function of fire resistance time is a complex calculation that would require several pages of calculations. In this example, an effective char depth of 3.8 inches involves the first 3 laminations which includes the first 2 strong-axis laminations. Rather than attempt to account for the relatively small contribution from the remaining portion of the 2nd strong axis lamination, and recognizing that the crossing ply does not contribute significantly to buckling resistance, the wall can be designed as an eccentrically-loaded 3-ply CLT column.

From PRG 320, select a 3-ply CLT panel made from the same 1-3/8 in x 3-1/2 in. lumber boards (CLT thickness of 4-1/8 inches) and the same CLT grade E1. The tabulated properties are:

Reference compression stress, $F_{c,0} = 1800$ psi	(PRG 320 Annex A, Table A1)
Reference bending moment, $F_b S_{\text{eff},0} = 4,525$ ft-lb/ft of width	(PRG 320 Annex A, Table A2)
Reference bending stiffness, $E_{\text{eff},0} = 115 \times 10^6$ lb-in ² /ft of width	(PRG 320 Annex A, Table A2)
Reference shear stiffness, $GA_{\text{eff},0} = 0.46 \times 10^6$ lb/ft of width	(PRG 320 Annex A, Table A2)

Calculate the effective wall compression capacity:

$$A_{\text{parallel}} = bd \text{ of strong axis plies} = 2(12)(1.375) = 33 \text{ in}^2/\text{ft of width} \quad (\text{NDS 10.3.1})$$

$$P_c = F_{c,0}(A_{\text{parallel}}) = (1800)(33) = 59,400 \text{ lb/ft of width} \quad (\text{NDS 10.3.1})$$

Calculate the apparent wall buckling capacity:

$$(EI)_{\text{app}} = \frac{115 \times 10^6}{1 + \frac{(11.8)(115 \times 10^6)}{(0.46 \times 10^6)(120)^2}} = 95.4 \times 10^6 \text{ lb/in}^2/\text{ft of width}$$

$$(EI)_{\text{app-min}} = (95.4 \times 10^6)(1 - 1.645(0.10))(1.03)/1.66 = 49.5 \times 10^6 \text{ lb/in}^2/\text{ft of width} \quad (\text{NDS 10.3.1})$$

Calculate the adjusted allowable column capacity (assuming $C_D=N/A$; $C_M=N/A$; $C_t=N/A$):

$$(EI)_{\text{app-min}}' = 49.5 \times 10^6 \text{ lb/in}^2/\text{ft of width} \quad (\text{NDS 10.3.1})$$

Using the general form of the Euler buckling equation:

$$P_{cE,f} = 2.03 \frac{\pi^2 (EI)_{\text{app-min}}}{L^2} = 2.03 \frac{\pi^2 (49.5 \times 10^6)}{(120)^2} = 68,900 \text{ lb per ft of width} \quad (\text{NDS C3.7.15})$$

$$P_c^* = 2.58 P_c = 2.58(59,400) = 153,300 \text{ lb/ft of width} \quad (\text{NDS C3.7.1.5})$$

$$\text{Use } c = 0.9 \text{ for CLT} \quad (\text{NDS C3.7.1.5})$$

$$\alpha_c = P_{cE,f}/P_c^* = 68,900/153,300 = 0.4494$$

$$C_p = \frac{1+\alpha_c}{2c} - \sqrt{\left(\frac{1+\alpha_c}{2c}\right)^2 - \frac{\alpha_c}{c}} = \frac{1+0.4494}{2(0.9)} - \sqrt{\left(\frac{1+0.4494}{2(0.9)}\right)^2 - \frac{0.4494}{0.9}} = 0.4192 \quad (\text{NDS C3.7.1.5})$$

$$P'_f = P_c^* C_p = 153,300 (0.4192) = 64,250 \text{ lb/ft of width} \quad (\text{NDS 3.7.1.5})$$

Fire Check: $P'_f \geq P_{\text{load}}$ **64,250 lb > 20,150 lb** \checkmark

Initially, the CLT wall is assumed to be loaded concentrically; however, one-sided charring of the wall creates load eccentricities. While the eccentricity created by an effective char depth, $a_{eff}=3.8"$ would be approximately 1.9", a 3-ply CLT is utilized for this fire design example. The eccentricity in this wall would therefore be:

$$e = (d_{7-ply} - d_{3-ply})/2 = (9.625 - 4.125)/2 = 2.75"$$

Calculate the resisting moment (assuming $C_D=N/A$; $C_M=N/A$; $C_t=N/A$; $C_L=1.0$)

$$M'_f = (2.85) F_b(S_{eff})(C_L) = 2.85(4,525)(1.0) = 12,900 \text{ ft-lb/ft of width} \quad (\text{NDS 16.2.2})$$

Using the general form of the wood column equations based on NDS Equation 15.4-3:

$$\left(\frac{P_{Load}}{P'_f}\right)^2 + \frac{(P_{Load} e)[1 + 0.234(P_{Load}/P_{CE,f})]}{M'_f[1 - (P_{Load}/P_{CE,f})]} \leq 1.0$$

Fire Check: $\left(\frac{20,150}{64,250}\right)^2 + \frac{(20,150)(2.75)[1 + 0.234(20,150/68,900)]}{(12,900)(12\frac{in}{ft})[1 - (20,150/68,900)]} = 0.64 \leq 1.0 \quad \checkmark$

There is conservatism in this example due to the simplifying assumption that the remaining cross-section after two hours is a 3-ply CLT wall. The conservatism can be estimated by back-calculating the time required for the first 3 laminations (includes 2 strong-axis and 1 weak-axis laminations) to char. The time required to char each lamination can be calculated using the equations in NDS 16.2-2 as:

$$t_{gl} = \left(\frac{h_{lam}}{\beta_t}\right)^{1.23} = \left(\frac{1.375}{1.5}\right)^{1.23} = 0.90 \text{ hrs}$$

$$t = n_{lam}t_{gl}/1.2 = 3(0.90)/1.2 = 2.25 \text{ hrs}$$

Note that, while the structural contribution of the fourth lamination, (a crossing ply), was ignored in these calculations, it does protect the last 3 laminations in the CLT. Accordingly, the fourth lamination could also be added:

$$t = 4(0.90)/1.2 = 3 \text{ hrs}$$

In fact, this CLT wall would be expected to have similar structural fire resistance from 2.25 to 3 hrs. A more rigorous analysis would demonstrate that the expected fire resistance of this CLT wall under these loading conditions is about 3 hours.

Thermal Separation:

ASTM E119 also requires wall assemblies to be checked for thermal separation wherein transmission of heat through the test specimen during the fire exposure period does not raise the average temperature on the unexposed surface more than 250°F (139°C) above its initial temperature. For CLT, char is assumed to fall off when charring reaches the glueline, therefore the contribution of each layer to thermal separation time is considered separately. Except for the final layer, the estimated contribution of each CLT layer to the thermal separation time is equal to the thermal protection time calculated in accordance with Equation 4.4-2 in 4.4.1.1:

$$t_p = 60 \left(\frac{d_p}{1.5}\right)^{1.23} = 60 \left(\frac{1.375}{1.5}\right)^{1.23} = 54 \text{ minutes}$$

If the CLT is used as an unbacked fire barrier, the estimated time to burn-through on the last layer, t_{bt} , is calculated using Equation 4.4-3a in Section 4.4.1.1:

$$t_{bt} = 60 \left(\frac{d_p - 0.6}{1.5} \right)^{1.23} + 17 = 60 \left(\frac{1.375 - 0.6}{1.5} \right)^{1.23} + 17 = 44 \text{ minutes}$$

From Section 4.4.1.3, the time assigned for thermal separation, t_{ts} , is calculated as:

$$t_{ts} = 6 * 54 + 0.85(44) = 361 \text{ minutes}$$

Thermal Separation Check: $t_{ts} \geq \text{FRR}$ **361 minutes > 120 minutes** ✓

Example 7: Protected 2x10 Joist Floor Assembly - Allowable Stress Design

Wood-frame floor located in a residential living area and framed with #2 grade 2x10 Hem-Fir joists spaced 16 in. on center. Floor joists protected with gypsum wallboard (GWB) on the fire-exposed edge of the joist. The unexposed edge of the joist is sheathed with 23/32" oriented strand board (OSB). Dead load = 10 psf, live load = 40 psf, L/Δ = 360. Based on maximum allowable span from 2018 IRC Table R502.3.1(2), joist span is limited to 15 feet, 2 inches. Calculate the required protection for a one-hour structural fire resistance time when subjected to an ASTM E119 fire exposure.

For the structural design of the wood joist, assume that the joist is a beam braced on the compression edge by the unexposed OSB.

Calculate joist load:

$$W_{load} = s (q_{dead} + q_{live}) = (16/12)(10+40) = 66.67 \text{ psf}$$

For the structural design of the wood joists, calculate the maximum induced moment:

$$M_{max} = W_{load} L^2 / 8 = (66.67)(15.2)^2 / 8 = 1920 \text{ ft-lb}$$

#2 grade 2x10 Hem-Fir joist:

$$F_b = 850 \text{ psi}$$

Calculate beam section modulus:

$$S_s = bd^2/6 = (1.5)(9.25)^2/6 = 21.4 \text{ in}^3$$

Calculate adjusted allowable bending stress (assuming $C_F=1.1$: $C_r=1.15$: $C_D=1.0$: $C_M=1.0$: $C_t=1.0$: $C_L=1.0$)

$$F'_b = F_b (C_F)(C_r)(C_D)(C_M)(C_t)(C_L) = 850 (1.1)(1.15)(1.0)(1.0)(1.0)(1.0) = 1075 \text{ psi} \quad (\text{NDS 5.3.1})$$

Calculate design resisting moment:

$$M_{s'} = F'_b S_s = (1075)(21.4)/12 = 1920 \text{ ft-lb}$$

Structural Check: $M_{s'} \geq M_{max}$ **1920 ft-lb \geq 1920 ft-lb** \checkmark

For the fire design of the wood beam, mass loss due to charring is conservatively neglected so the loading is unchanged. Therefore, the maximum induced moment is unchanged. The fire resistance must be calculated.

Option #1: 2x10 Joists protected with 5/8" Type X GWB

Calculate joist section properties, accounting for the exposure of each face of the joist. The fire-exposed edge and the sides of the joist will begin to char when the GWB protection time, t_{GWB} , is exceeded. From Table 4.4.2.1, select a single layer of 5/8" Type X GWB with an assigned $t_{GWB}=40$ minutes.

Determine the effective char depth, a_{eff} :

$$\begin{aligned} a_{eff} &= 1.8 \text{ inches} && (\text{NDS Table 16.2.1A}) \\ b_{eff} &= b - 2a_{eff} = b - 2[1.8*(1-t_{GWB})^{0.813}] = 1.5 - 2[1.8*(1-40/60)^{0.813}] = 0.03 \text{ in.} && (\text{NDS 16.2.1}) \\ d_{eff} &= d - a_{eff} = d - [1.8*(1-t_{GWB})^{0.813}] = 9.25 - [1.8*(1-40/60)^{0.813}] = 8.51 \text{ in.} && (\text{NDS 16.2.1}) \\ S_f &= (b_{eff})(d_{eff})^2/6 = (0.03)(8.51)^2/6 = 0.32 \text{ in}^3 && (\text{NDS 16.2.1}) \end{aligned}$$

Calculate the adjusted bending strength (assuming $C_F=1.1$: $C_r=1.15$: $C_D=N/A$: $C_M=N/A$: $C_t=N/A$: $C_L=1.0$)

$$F'_{b,f} = (2.85) F_b (C_F)(C_r)(C_L) = 2.85(850)(1.1)(1.15)(1.0) = 3064 \text{ psi} \quad (\text{NDS 16.2.2})$$

Calculate the resisting moment:

$$M_f' = F'_{b,f} S_f = (3064)(0.32)/12 = 81 \text{ ft-lb} \quad (\text{NDS 16.2.2})$$

Fire Check: $M_f' \geq M_{max}$ **81 ft-lb $<$ 1920 ft-lb** **X**

Option #2: 2x10 Joists protected with 3.5" FGI between joists & 5/8" Type X GWB

Calculate joist section properties, accounting for the exposure of each face of the joist. The fire-exposed edge of the joist will begin to char when the GWB protection time, t_{GWB} , is exceeded. The sides of the joist will begin to char when the GWB protection time is exceeded and the protection from the insulation, t_{ins} , is exceeded. From Table 4.4.2.1, select a single layer of 5/8" Type X GWB with an assigned $t_{GWB}=40$ minutes. From Table 4.4.3.1, select 3.5" fiberglass insulation (FGI) with an assigned $t_{ins}= 3$ minutes.

Determine the effective char depth, a_{eff} :

$$a_{eff} = 1.8 \text{ inches} \quad (\text{NDS Table 16.2.1A})$$

$$b_{eff} = b - 2a_{eff} = b - 2[1.8*(1-t_{GWB}-t_{ins})^{0.813}] = 1.5 - 2[1.8*(1-40/60-3/60)^{0.813}] = 0.21 \text{ in.} \quad (\text{NDS 16.2.1})$$

$$d_{eff} = d - a_{eff} = d - [1.8*(1-t_{GWB})^{0.813}] = 9.25 - [1.8*(1-40/60)^{0.813}] = 8.51 \text{ in.} \quad (\text{NDS 16.2.1})$$

$$S_f = (b_{eff})(d_{eff})^2/6 = (0.21)(8.51)^2/6 = 2.5 \text{ in}^3 \quad (\text{NDS 16.2.1})$$

Calculate the adjusted bending strength (assuming $C_D=N/A$: $C_M=N/A$: $C_t=N/A$: $C_L=1.0$)

$$F'_{b,f} = (2.85) F_{b,f} (C_F)(C_r)(C_L) = 2.85(850)(1.1)(1.15)(1.0) = 3064 \text{ psi} \quad (\text{NDS 16.2.2})$$

Calculate the resisting moment:

$$M_r' = F'_{b,f} S_f = (3064)(2.5)/12 = 643 \text{ ft-lb} \quad (\text{NDS 16.2.2})$$

Fire Check: $M_r' \geq M_{max}$ **643 ft-lb < 1920 ft-lb** **x**

Option #3: 2x10 Joists protected with 1.5" (2.5 pcf) MWI between joists & 5/8" Type X GWB

Calculate joist section properties, accounting for the exposure of each face of the joist. The fire-exposed edge of the joist will begin to char when the GWB protection time, t_{GWB} , is exceeded. The sides of the joist will begin to char when the GWB protection time is exceeded and the protection from the insulation, t_{ins} , is exceeded. From Table 4.4.2.1, select a single layer of 5/8" Type X GWB with an assigned $t_{GWB}=40$ minutes. From Table 4.4.3.1, select mineral wool insulation (MWI) with an assigned $t_{ins}=17$ minutes.

Determine the effective char depth, a_{eff} :

$$a_{eff} = 1.8 \text{ inches} \quad (\text{NDS Table 16.2.1A})$$

$$b_{eff} = b - 2a_{eff} = b - 2[1.8*(1-t_{GWB}-t_{ins})^{0.813}] = 1.5 - 2[1.8*(1-40/60-17/60)^{0.813}] = 1.32 \text{ in.} \quad (\text{NDS 16.2.1})$$

$$d_{eff} = d - a_{eff} = d - [1.8*(1-t_{GWB})^{0.813}] = 9.25 - [1.8*(1-40/60)^{0.813}] = 8.51 \text{ in.} \quad (\text{NDS 16.2.1})$$

$$S_f = (b_{eff})(d_{eff})^2/6 = (1.32)(8.51)^2/6 = 15.9 \text{ in}^3 \quad (\text{NDS 16.2.1})$$

Calculate the adjusted bending strength (assuming $C_D=N/A$: $C_M=N/A$: $C_t=N/A$: $C_L=1.0$)

$$F'_{b,f} = (2.85) F_{b,f} (C_F)(C_r)(C_L) = 2.85(850)(1.1)(1.15)(1.0) = 3064 \text{ psi} \quad (\text{NDS 16.2.2})$$

Calculate the resisting moment:

$$M_r' = F'_{b,f} S_f = (3064)(15.9)/12 = 4060 \text{ ft-lb} \quad (\text{NDS 16.2.2})$$

Fire Check: $M_r' \geq M_{max}$ **4060 ft-lb > 1920 ft-lb** **√**

Simplified alternative approach (using Component Additive Method):

Time assigned to Joist (Appendix B, Table B1)	11 minutes
Time assigned to 5/8" Type X GWB (Table 4.4.2.1)	40 minutes
Time assigned to 3.5" fiberglass insulation (Table 3.3f)	2 minutes
Time assigned to 1.5" (2.5 pcf) mineral wool insulation (Table 3.3f)	13 minutes

Option #1: 2x10 Joists protected with 5/8" Type X GWB	51 minutes	x
Option #2: 2x10 Joists protected with 3.5" FGI & 5/8" Type X GWB	53 minutes	x
Option #3: 2x10 Joists protected with 1.5" (2 pcf) MWI & 5/8" Type X GWB	64 minutes	√

Thermal Separation:

ASTM E119 also requires floor assemblies to be checked for thermal separation wherein transmission of heat through the test specimen during the fire exposure period does not raise the average temperature on the unexposed surface more than 250°F (139°C) above its initial temperature. There are three elements in the floor assembly that provide thermal separation: the single layer of 5/8" Type X GWB, the insulation, and the flooring. If a single layer of 23/32" wood structural panel is used as the unbacked flooring layer on the unexposed side, the estimated contributions are: 40 minutes for the GWB from Table 4.4.2.1; 17 minutes for the MWI from Table 4.4.3.1; and the time to char-through of the wood structural panel, t_{bt} , is estimated using Section 4.4.1.1:

$$t_p = 60 \left(\frac{d_p - 0.6}{1.5} \right)^{1.23} + 17 = 60 \left(\frac{23/32 - 0.6}{1.5} \right)^{1.23} + 17 = 19.7 \text{ minutes} \quad \text{Equation 4.4-2}$$

From Section 4.4.1.3, the time assigned for thermal separation, t_{ts} , is calculated as:

$$t_{ts} = 40 + 17 + 0.85 t_{bt} = 40 + 17 + 0.85(19.7) = 74 \text{ minutes}$$

Thermal Separation Check: $t_{ts} \geq \text{FRR}$ **74 minutes > 60 minutes** ✓

Example 8: Protection of Steel Ledger Connection - Allowable Stress Design

A steel ledger (L7x4x3/8) attached with 1/2-inch x 6-inch lag screws at 12 inches on center to a 5-ply CLT wall, supporting a 5-ply CLT floor. Exposed CLT wall and floor are designed for 2-hr structural fire resistance time when subjected to an ASTM E119 fire exposure. Design connection protection.

Connection Design

Because of the relatively high thermal conductivity of steel, all steel components of the ledger and the ledger-to-wall lag screws connecting the steel ledger to the CLT wall must be protected for the full FRR time. Fasteners attaching the wood protection do not need to be protected; however, they should be of sufficient length to ensure that the wood protection stays in place for the required time.

Protection of Steel Ledger and Ledger-to-Wall Lag Screws with wood cover

If a single layer of wood cover is designed to provide thermal separation between the fire exposure and the steel connectors, fasteners, and portions of the wood members included in the connection design, provisions of 4.4.1.3 should be used. For 2-hr protection, the thickness of the wood cover is designed assuming the $t_p = t/0.85$ and back solving Equation 4.4-2 to estimate the depth of the wood cover:

$$t_p = 120/0.85 = 60 \left(\frac{d_p}{1.5} \right)^{1.23} \text{ minutes}$$

$$d_p = 1.5 \left(\frac{120}{0.85(60)} \right)^{0.813} = 3.0 \text{ inches}$$

The bottom leg of the steel ledger extends 4 inches from the wall; therefore, the wood cover needs to extend at least 7 inches from the wall. Using standard sizes of sawn lumber, this would require the use of a nominal 4x8 (3.5" x 7.25"). The wood cover should be fastened to the CLT floor slab to ensure that it does not separate from the floor slab

If nominal 2x8 (1.5" x 7.25") dimension lumber were used to provide thermal separation, discrete attachment of the lumber would result in some localized char falloff of each layer. Per 4.4.1.3, the protection provided by the base layer would be $0.85t_p$, and subsequent layers would provide t_p calculated using Equation 4.4-2 as follows:

$$t_p = 60 \left(\frac{1.5}{1.5} \right)^{1.23} = 60 \text{ minutes}$$

In this arrangement, the base layer would provide 51 minutes and subsequent layers would provide 60 minutes. To achieve the required 2-hr thermal separation, three 2x8 layers would be required. This option will be used for the remaining portion of this connection design (see Figure 8-1).

Gap protection

The leg of the L7x4x3/8 steel ledger will create a 3/8" gap between the wood cover and the CLT floor. This gap must be filled to ensure that flames and hot gases will not heat the steel and char the CLT floor prematurely. This gap could be filled with a layer of 3/8" GWB, attached directly to the CLT floor.

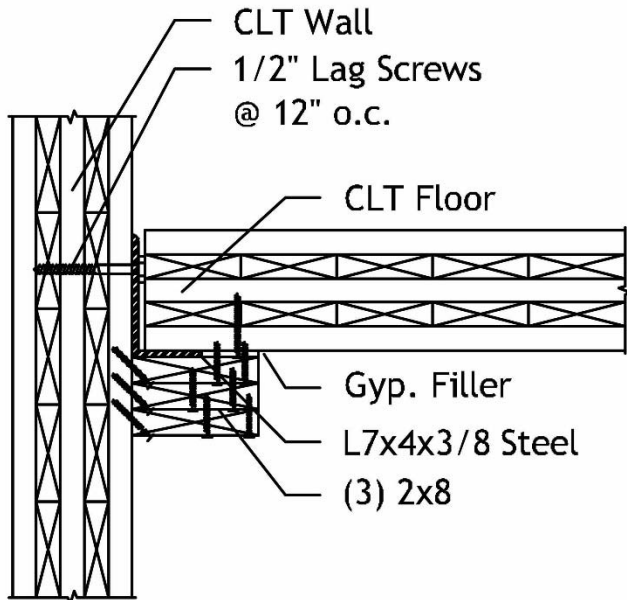

Figure 8-1. Initial wood cover design

Char contraction

The effects of char contraction must be considered at the intersection of the wood cover and the CLT wall, the intersection of the wood cover and the CLT floor slab, and at abutting ends of the wood cover, if they exist. As the fire progresses, the char will contract on both the CLT surfaces and the wood cover, exposing the interior areas of the connection to flames and hot gases.

Figure 8-2 depicts a scenario where the gaps created by the char contraction could allow ignition deep within the intersection of the wood cover and the CLT wall and between the wood cover and the CLT floor slab. In this configuration, the depth of the gap created by the char contraction is estimated to be twice the depth of the char layer (see 4.4.1.4), which would double the total depth of charring at the end of the wood cover, prematurely exposing the CLT floor, steel connector, and/or connector fasteners to significantly elevated temperatures. Since ignition occurs when the wood is initially exposed due to char contraction, the elevated temperature zone does not extend beyond the point of ignition into the gap. If three 2x8's are used for the wood cover, the time at which the char front in the gap would reach the steel ledger from the bottom side of the cover can be calculated as follows:

$$t = 60 \left(\frac{d_p}{2\beta_t} \right)^{1.23} = 60 \left(\frac{3(1.5)}{2(1.5)} \right)^{1.23} = 99 \text{ minutes} \quad \text{(Equation 4.4-2)}$$

From the end of the cover can be calculated as follows:

$$t = 60 \left(\frac{7.25 - 4}{2(1.5)} \right)^{1.23} = 66 \text{ minutes}$$

For the wood cover to CLT wall and cover to CLT floor slab intersections, additional wood can be added that would delay the formation of a gap between the wood cover and the CLT due to char contraction (see Figure 8-3). The wood cover should be fastened to the CLT wall to ensure that it does not separate from the wall.

The dimensions of the additional wood only need to prevent gaps from being created long enough to ensure that the elevated temperature associated with ignition at the end of the member does not reach the connection for the required fire resistance time. To satisfy this condition, the minimum

thickness of the additional wood can be calculated as follows:

$$d_{cover} + d_{added} \geq 2a_{char}$$

$$a_{char} = 1.5t^{0.813} = 1.5(2)^{0.813} = 2.64 \text{ inches}$$

CLT Wall: $d_{added} \geq 2a_{char} - d_{cover} \geq 2(2.64) - 4.5 = 0.8 \text{ inches}$

CLT Floor: $d_{added} \geq 2a_{char} - d_{cover} \geq 2(2.64) - (7.25 - 4) = 2.0 \text{ inches}$

For the additional wood required at the intersection of the wood cover and the CLT wall, a nominal 2x2 (1.5" x 1.5") would meet the 0.8" requirement. The width of the wood strip must be equal to or greater than the thickness of the strip. For the additional wood required at the intersection of the wood cover and the CLT floor slab, the 2x8's can be increased to 2x10's.

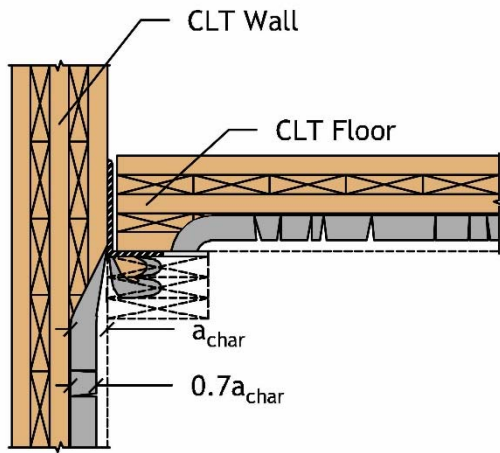

Figure 8-2. Char pattern due to char contraction

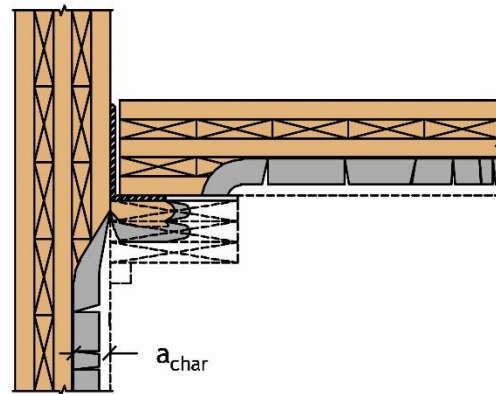

Figure 8-3. Char pattern with wood strip added

If abutting ends of the wood cover occur, staggering of the wood cover layers would be the most efficient means of meeting the requirements.

To calculate the effect of staggering the abutting ends of the wood cover layers, the abutting ends in adjacent layers must be staggered a sufficient distance to prevent char contraction in multiple layers. If each cover end is staggered at least 12 inches from cover ends in adjacent layers, then the time at which the elevated temperature in the gap of the face layer of the protection would reach the char temperature would be calculated as follows:

$$t = 60 \left(\frac{d_p}{2\beta_t} \right)^{1.23} = 60 \left(\frac{1.5}{2(1.5)} \right)^{1.23} = 25.5 \text{ minutes} \quad (\text{Equation 4.4-2})$$

The minimum thickness of the remaining layers can then be determined for the remaining 94.5 minutes as done previously. In this arrangement, the base layer would provide 51 minutes and subsequent layers would provide 60 minutes. To achieve the required 2-hr thermal separation, a total of three 2x10 wood cover layers would be required.

The final protection design would require three 2x10's, with end joists in adjacent layers staggered at least 12 inches, and a nominal 2x2 (1.5"x1.5") piece of lumber used for the wood strip at the CLT wall

as shown in Figure 8-4. Fasteners attaching the wood strip do not need to be protected; however, they should be of sufficient length to ensure that the wood strip stays in place for the required time (e.g. wood screws penetrating the adjacent wood cover layer or CLT member at least 1 inch).

Note: The wood cover and wood strip can be incorporated into the design as decorative trim; however, attachment of the wood strip shall be made with small diameter steel fasteners (i.e. not aluminum or other light metal finish nails).

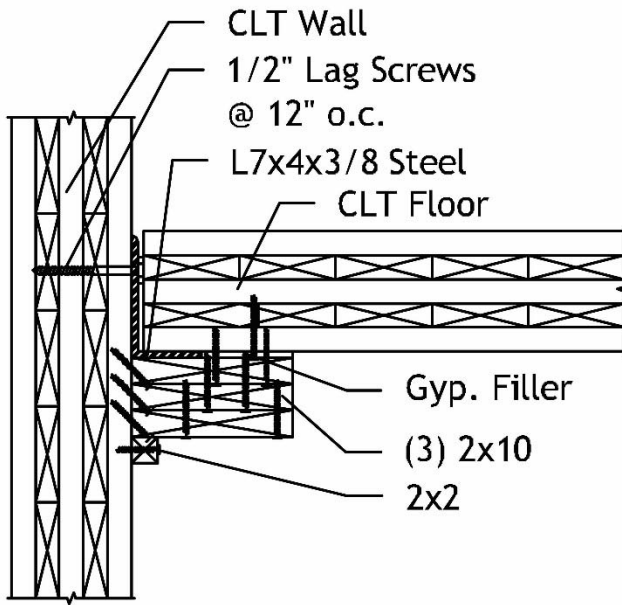

Figure 8-4. Final wood protection design

Protection of Steel Ledger and Ledger-to-Wall Lag Screws with Type X gypsum wallboard

In lieu of additional wood cover calculated previously, 5/8" Type X gypsum wallboard (GWB) could be used to provide the thermal separation. Multiple layers would be required. Per 4.4.2, the protection time provided by outer layers would be $t_p=40$ minutes/layer and the base layer would be $0.5t_p$ or 20 minutes. To achieve the required 2-hr thermal separation, four layers of 5/8" Type X GWB would be required.

Gap protection

The gap created by the leg of the L7x4x3/8 steel ledger would still need to be filled and could be filled with a layer of 3/8" GWB, attached directly to the CLT floor (see Figure 8-5).

Gypsum Board Contraction

The effects of char contraction and GWB contraction may be lessened or mitigated through use of fire-stopping materials such as mineral wool insulation, intumescent tapes and fire sealants. It is up to the designer to determine, in consultation with the fire-stop product manufacturer and the authority having jurisdiction, the applicability of such products and to verify their performance within the assembly by means of test data or other substantiated performance indicators.

Example 9: Protection of Beam-Column Connection - Allowable Stress Design

The 6¾" x 13½" 24F-V4 Douglas-fir glulam beam from Example 1 is connected to an exposed CLT wall with a hidden connector as shown in Figure 9-1. From Example 1, the shear load is 6,750 lbf. The hidden bearing connector is 3.5 inches wide and is 0.375 in. thick. The bolts do not extend beyond the edges of the bearing plate, as shown in Figure 9-1. The exposed glulam beam and CLT wall are designed for 1-hr structural fire resistance time when subjected to an ASTM E119 fire exposure. Design connection protection.

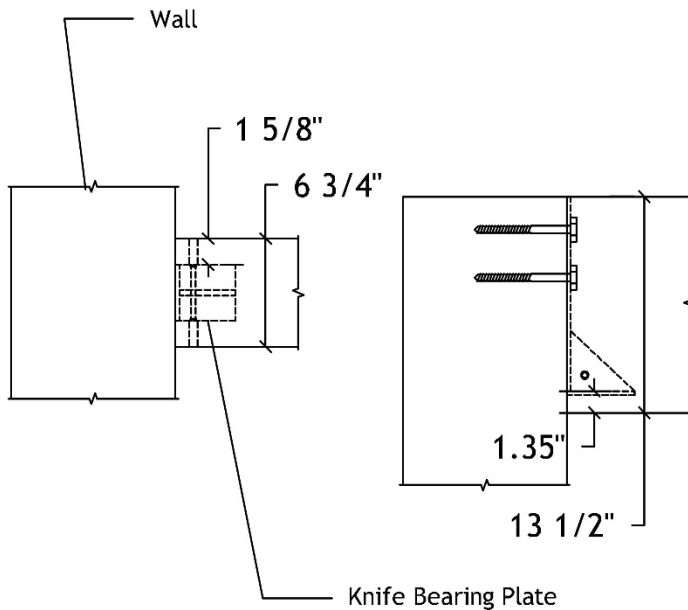

Figure 9-1. Exposed glulam beam and exposed CLT wall connection

Protection of Steel Bearing Connector and Bolts with wood cover

To provide thermal separation between the fire exposure and the steel connectors, fasteners, and portions of the wood members included in the connection design, provisions of 4.4.1.3 should be used.

To embed the bearing plate, the glulam beam must be notched. The notch depth on the tension edge of a glulam bending member is limited to the lesser of 1/10 of the beam depth or 3 inches (NDS 5.4.5); therefore, the maximum notch depth permitted in the 13½" deep beam would be 1.35 inches. The depth of the protection provided below the connector, accounting for the 3/8" thick steel bearing plate, would be 0.975. The protection provided by the wood outside of the connection is estimated assuming $t_p = t/0.85$ in Equation 4.4-2:

$$t_p = 0.85(60) \left(\frac{d_p}{1.5} \right)^{1.23} = (0.85)(60) \left(\frac{0.975}{1.5} \right)^{1.23} = 30 \text{ minutes}$$

Additional wood cover is required at the bottom of the beam to provide the additional 30 minutes of the required 1-hr fire resistance. The minimum depth of the added cover, attached to the bottom of the beam, would be:

$$d_{cover} = 1.5 \left(\frac{30}{60} \right)^{0.813} = 0.85 \text{ inches}$$

The protection provided by the wood on the sides of the steel bearing plate connector is estimated assuming $t_p = t/0.85$ in Equation 4.4-2:

$$d_p = [6.75 - 3.5]/2 = 1.625 \text{ inches}$$

$$t_p = (0.85)(60) \left(\frac{1.625}{1.5} \right)^{1.23} = 56.3 \text{ minutes}$$

Additional wood cover is required on each side of the beam to provide the additional 3.7 minutes of the 1-hr fire resistance. The minimum depth of the added cover, attached to the sides of the beam, would be:

$$d_{cover} = 1.5 \left(\frac{3.7}{60} \right)^{0.813} = 0.16 \text{ inches}$$

Assuming the length of the steel bearing plate and the thickness of the steel projects the connection 3/8" from the wall, the length of the wood cover would need to be at least 5.575 inches long (3.5" + 0.375" + 1.7"). In order to aid in fastening the wood protection to the wood beam, a nominal 2x8 (1.5" x 7.25") is chosen for the bottom and sides of the beam (see Figure 9-2).

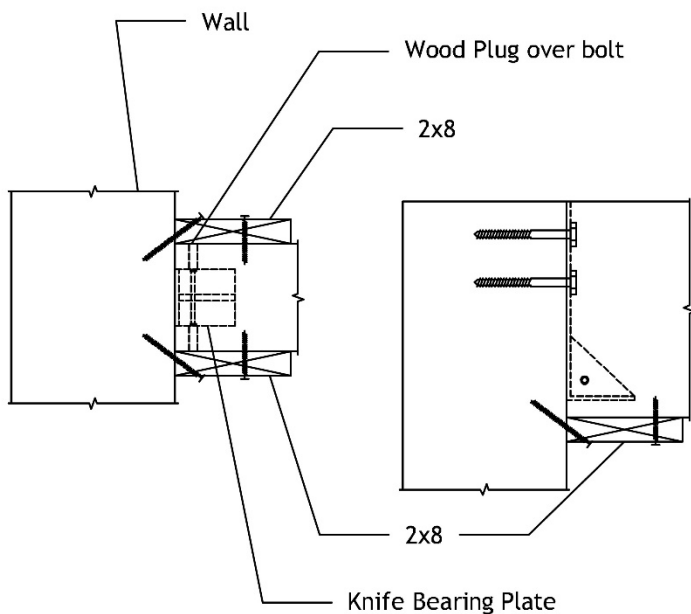

Figure 9-2. Design of wood cover

Char contraction

As the fire progresses, the char will contract on both the CLT wall and the glulam beam, exposing the interior areas of the connection located at the ends of the wood member to flames and hot gases.

Figure 9-3 depicts a scenario wherein the gap created by the char contraction would allow ignition at the end of the glulam beam. In this configuration, the depth of the gap created by the char contraction is estimated to be twice the depth of the char layer (see 4.4.1.4), which would potentially expose the steel connector, and/or connector fasteners to elevated temperatures prematurely. Since ignition occurs when the wood is initially exposed due to char contraction, the elevated temperature zone does not extend beyond the point of ignition into the gap. The time at which the elevated temperature

due to ignition in the gaps would reach the steel connector at the end of the glulam beam if the 2x8 wood cover is used, can be calculated as follows:

$$t = 60 \left(\frac{d_p}{2\beta_t} \right)^{1.23} = 60 \left(\frac{0.975+1.5}{2(1.5)} \right)^{1.23} = 47 \text{ minutes} \quad (\text{Equation 4.4-2})$$

To address char contraction at the intersection of the beam with the CLT wall, a wood strip could be used (Figure 9-4). The time at which the elevated temperature in the gap would reach the steel connector at the end of the glulam beam would be 47 minutes. The wood strip only needs to prevent the gap from being created long enough to ensure that the elevated temperature associated with ignition at the end of the member does not reach the connection for the required fire resistance time.

$$d_{cover} + d_{strip} \geq 2a_{char}$$

$$d_{strip} \geq 2(1.5) - [0.975 + 1.5] = 0.525 \text{ inches}$$

Char penetration between the protection and the sides of the beam are also checked but no further protection is required (Figure 9-5).

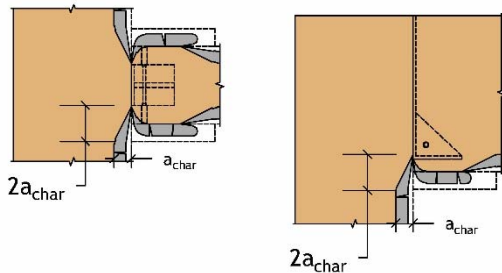

Figure 9-3. Char pattern due to char contraction

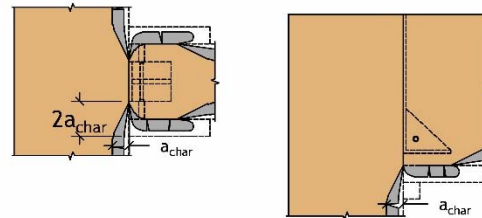

Figure 9-4. Char pattern with wood strip added

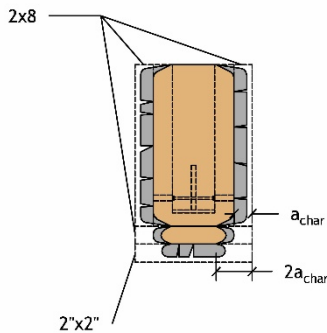

Figure 9-5. Char pattern across beam cross-section

A nominal 2x2 (1.5"x1.5") piece of lumber or equivalent could be used for the wood strip at the bottom of the beam as shown in Figure 9-6.

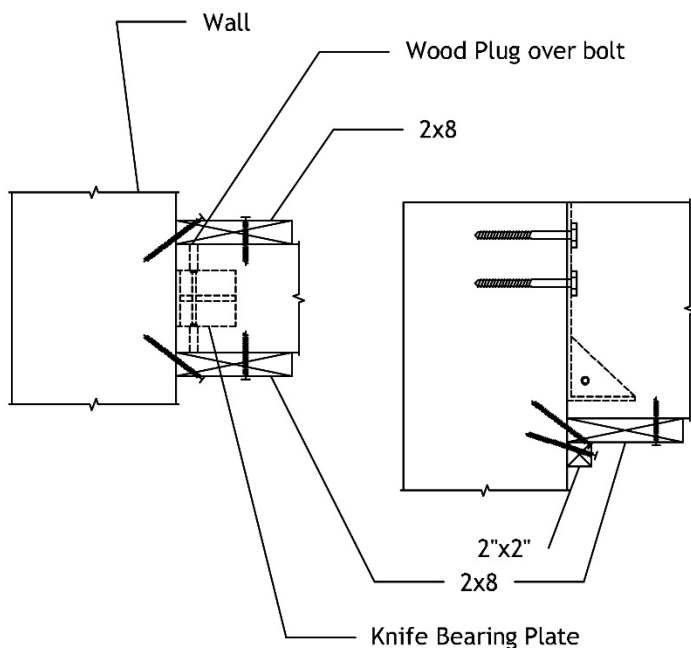

Figure 9-6. Final wood protection design

Protection of Steel Bearing Connector and Bolts with wood cover and Type X gypsum wallboard

In lieu of additional wood cover calculated previously, 1/2" or 5/8" Type X gypsum wallboard (GWB) could be used to provide the additional 30 minutes at the bottom of the beam and 4 minutes at the sides of the beam to meet the 1-hr fire resistance. A single layer of 1/2" or 5/8" Type X GWB would provide 30 or 40 minutes, respectively, of additional fire resistance time in accordance with 4.4.2.1. The contribution of the gypsum does not need to be reduced based on provisions of 4.4.2.3, because the gypsum is not the only layer or final layer of protection for the connection.

Gypsum Board Contraction

The effects of char contraction and GWB contraction may be lessened or mitigated through use of fire-stopping materials such as mineral wool insulation, intumescent tapes and fire sealants. It is up to the designer to determine, in consultation with the fire-stop product manufacturer and the authority having jurisdiction, the applicability of such products and to verify their performance within the assembly by means of test data or other substantiated performance indicators.

Example 10: Protection of Tension Splice Connection - Allowable Stress Design

The 6x6 (5½" x 5½") Hem-Fir #2 grade timber in Example 3 is spliced at midspan using a hidden steel splice plate and a single row of drift pins as shown in Figure 10-1. The steel splice plate (¼" thick by 3" wide by 15.5" long) is attached to the wood members with six ¼" diameter x 3-¼" long drift pins in each member. Wood plugs are used as cover for the drift pins. The exposed tension member is designed for 1-hr structural fire resistance time when subjected to an ASTM E119 fire exposure. Design connection protection.

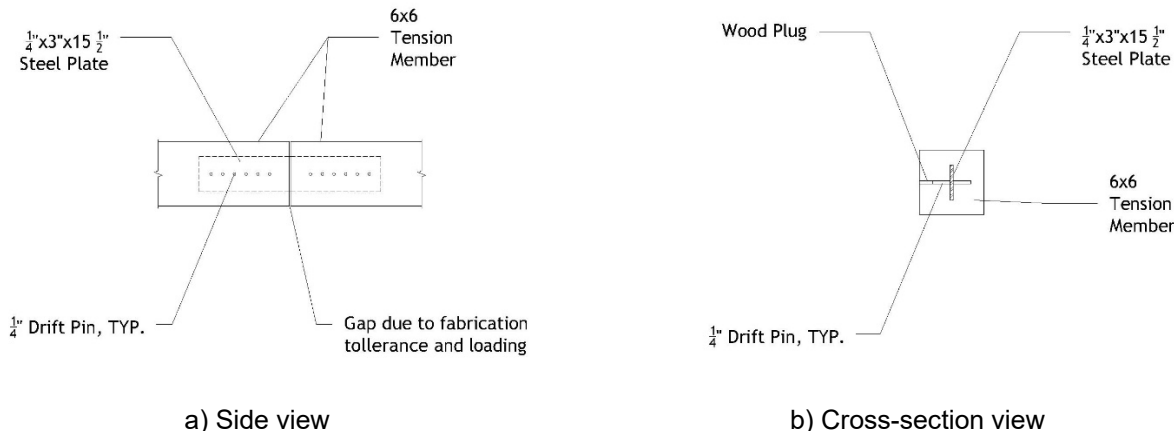

Figure 10-1. Tension splice connection a) side view, b) cross-section view

Protection of Steel Splice Plate and Drift Pins with wood cover

In accordance with 4.5.1, protection of wood structural connections shall be designed to limit the average temperature rise at the interface between the connection and the protection to 250 °F (139 °C), and the maximum temperature rise at any point to 325 °F (181 °C), Design of the protection shall be in accordance with the thermal separation provisions of 4.4.1.3 for wood protection and 4.4.2.3 for gypsum board protection. The portions of the connection that are required to be protected include the steel splice plate, the drift pins, and portions of the wood members included in the connection design, outlined in red the cross-section view of Figure 10-2. The remaining wood outside the protected connection area will contribute to the overall thermal protection of the connection.

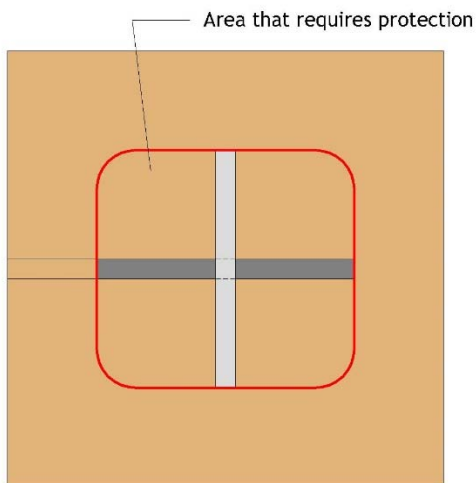

Figure 10-2. Portions of the connection that are required to be protected

The drift pins are protected at the ends by tight-fitting wood plugs used to fill the access holes that extend from the tip of the drift pins to the surface of the structural wood side member. Assuming wood plugs are used to fill the holes to the tips of the drift pins, the protection provided by the wood outside the protected connection area, bounded on the sides by the ends of the drift pins, is estimated using Equation 4.4-2:

$$d_p = [5.5 - 3.25]/2 = 1.125 \text{ inches}$$

$$t_p = (60) \left(\frac{d_p}{1.5} \right)^{1.23} = (60) \left(\frac{1.125}{1.5} \right)^{1.23} = 42.1 \text{ minutes}$$

In accordance with Section 4.4.1.3, the thermal separation time assigned to this layer of wood protection is multiplied by 85%; therefore, t_{op} =35.8 minutes. Additional wood cover is required to provide the additional 24.2 minutes of the 1-hr fire resistance. The minimum depth of the added wood cover would be calculated per Equation 4.4-2:

$$d_{cover} = 1.5 \left(\frac{24.2}{60} \right)^{0.813} = 0.72 \text{ inches}$$

Since a 3" wide splice plate is used, the total required width of the connection would be 3 inches. Prior calculations indicated that a smaller wood cross-section can be used to resist the tension load during fire exposure; however, this is the minimum dimension of the connection. Assuming that the groove for the connection is 1/4" wider than the steel plate to accommodate fabrication and assembly, the protection provided by the wood outside the splice plate and the wood cover required for protection are the same thicknesses as calculated above for protection of the steel drift pins.

For this preliminary design, 1x (0.75" actual thickness) is chosen for the added protection on the top, bottom, and sides of the connection. The length of the 1x wood cover on the four sides of the 6x6 member will be determined in the next section.

One final design consideration is the likely creation of a gap at the abutting ends of the wood tension members, either due to construction tolerances or as the tension members are loaded. Because the gap would be open to the steel splice plate on all four surfaces, the added wood protection would need to provide all of the thermal protection requiring the boards to overlap at the edges. If the 1x6 boards are located on the sides, the top and bottom 1x boards would need to be 1x8 (0.75"x7.25"). The time provided by the 1x protection at the gap is:

$$t_p = (0.85)(60) \left(\frac{0.75}{1.5} \right)^{1.23} = 21.7 \text{ minutes}$$

Additional wood cover is required to provide the additional 38.3 minutes of the 1-hr fire resistance. The minimum depth of the added wood cover would be:

$$d_{cover} = 1.5 \left(\frac{38.3}{60} \right)^{0.813} = 1.0 \text{ inches}$$

For this preliminary design, an additional nominal 2x (1.5" actual thickness) lumber collar is chosen for the added protection on the top, bottom, and sides of the connection at the gap (see Figure 10-3). The sides of the collar would be 2x lumber of 7-inch length and the top and bottom of the collar would be 2x lumber of 10-inch length. The width of the 2x lumber collar will be determined in the next section.

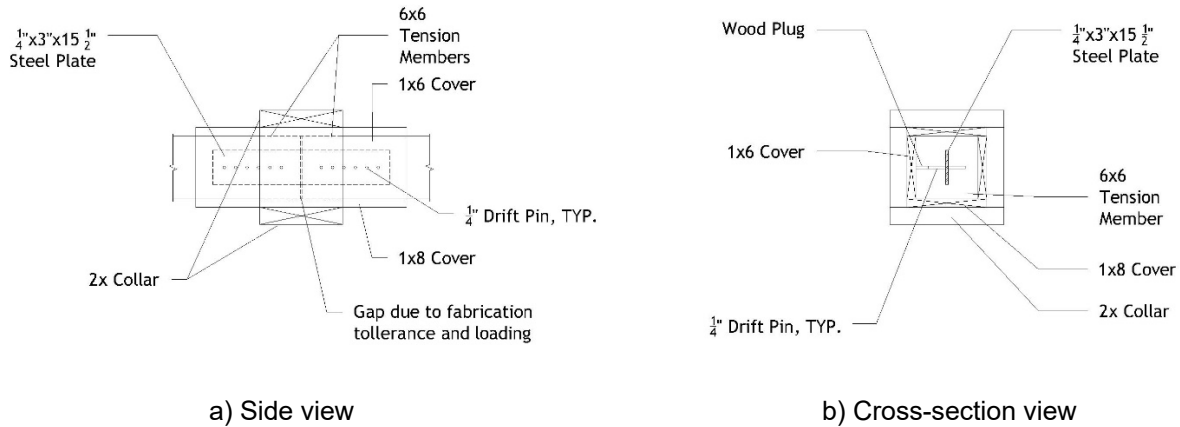

Figure 10-3. Fire protection wood cover and wood collar. a) side view, b) cross-section view

Required Wood Cover Length and Wood Collar Width Considering Char contraction

As the fire progresses, char will contract, creating a gap between wood protection and the protected wood member. Since most of the charring will occur in the added protection, contraction needs to consider the effect on the added protection. The gap created by char contraction will allow ignition of the protected member to penetrate behind the added protection starting from the ends of the protection; therefore, the length of the cover and the width of the collar must be sufficient to provide protection after consideration of char contraction.

The penetration of the gap created by the char contraction is estimated to be twice the char depth (see 4.4.1.4). Since ignition occurs when the wood is initially exposed due to char contraction, the elevated temperature zone does not extend beyond the point of ignition into the gap.

Required Length of Wood Cover

Char contraction will result in increased charring in the protected tension member beneath the wood cover. To determine the impact of charring and char contraction on the initial design of the 1x wood cover, the following times and char dimensions are calculated:

- Char in 6x6 w/o 1x cover: $a_{char} = 1.5$ inches $t_p = 60$ minutes
- Char through 1x cover: $d_{cover} = 0.75$ inches $t_p = 25.6$ minutes
- Char in 6x6 w/ 1x cover: $a_{char} = 0.95$ inches $t_p = 60 - 25.6 = 34.4$ minutes
- Char contraction at 1x cover: $a_{cont} = 0.75$ inches $L_{cont} = 2a_{contraction} = 1.5$ inches

At one hour, the depth of char in the 6x6 outside the 1x cover is 1.5 inches. The depth of char in the 6x6 under the 1x cover is 0.95 inches. The char depth in the 6x6 ranges from 1.5 inches to 0.95 inches over a distance of 1.5 inches. If the 1x cover is extended 1.5 inches beyond the steel connector, then the elevated temperature zone is prevented from reaching the steel connector (See Figure 10-4). The 1x6 and 1x8 wood covers must be 3 inches longer than the steel connector, at least 18.5 inches long, and centered on the connection.

Two other useful dimensions are the depth of the elevated temperature zone, t_{ETZ} , which can be approximated by increasing a_{char} of the closest layer by 0.14 (derived from Equation 4.5-5), and the thickness of the char layer, t_{char} , can be approximated by multiplying a_{char} of each layer by 0.7 (derived from Equation 4.4-4). The thicknesses of t_{ETZ} and t_{char} at two locations are of interest:

- 6x6 w/o 1x cover: $t_{ETZ} = 0.14(1.5) = 0.21$ inches $t_{char} = 0.7(1.5) = 1.05$ inches
- 6x6 w/ 1x cover: $t_{ETZ} = 0.14(0.95) = 0.13$ inches $t_{char} = 0.7(0.95) = 0.67$ inches

Required Length of Wood Collar

Due to char contraction, charring beneath the wood collar. To determine the impact of charring and char contraction on the initial design of the wood collar, the following times and char dimensions are

calculated:

- Char in 6x6 w/ 1x cover, w/o collar: $a_{char} = 0.95$ inches $t_p = 60$ minutes
- Char in 2x collar: $a_{char} = 1.5$ inches $t_p = 60$ minutes
- Char contraction at 2x collar: $a_{cont} = 1.5$ inches $L_{cont} = 2a_{contraction} = 3.0$ inches

At one hour, the depth of char in the 6x6 beneath the 1x cover, but outside the 2x collar is 0.95 inches, as determined earlier. The depth of char in the 2x collar is 1.5 inches. The char depth ranges from 0.95 inches in the 6x6 to 1.5 inches in the 2x collar over a distance of 3.0 inches. If the 2x collar is extended 3 inches on either side of the gap between abutting ends of the tension members, then the elevated temperature zone is prevented from reaching the gap and the connector (See Figure 10-4). A 2x8 (minimum) collar will be required.

The thicknesses of t_{ETZ} and t_{char} at two locations are of interest:

- 6x6 w/ 1x cover, w/o 2x collar: $t_{ETZ} = 0.14(0.95) = 0.13$ inches $t_{char} = 0.7(0.95) = 0.67$ inches
- 2x collar: $t_{ETZ} = 0.14(1.5) = 0.21$ inches $t_{char} = 0.7(1.5) = 1.05$ inches

However, since the 2x collar is completely consumed at 1 hour, the elevated temperature zone extends into the 1x cover by 0.21 inches.

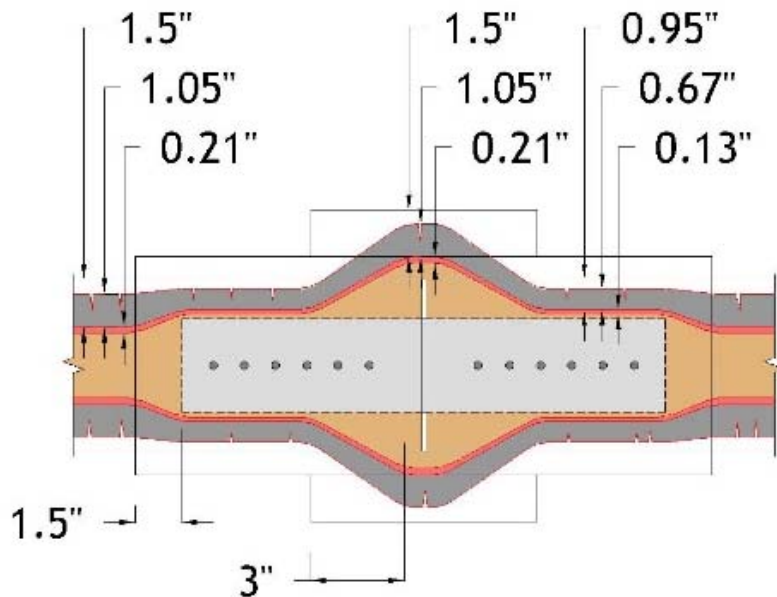

Figure 10-4. Char pattern and calculated dimensions including the effects of char contraction

For the final design, 18.5" long nominal 1x6 (0.75" x 5.5") and 1x8 (0.75" x 7.25") cover boards are chosen for the added protection on the top, bottom, and sides of the connection (see Figure 10-5). In addition, nominal 2x8 (1.5" x 7.25") boards are added to create a collar to protect the gap that would likely occur between the abutting ends.

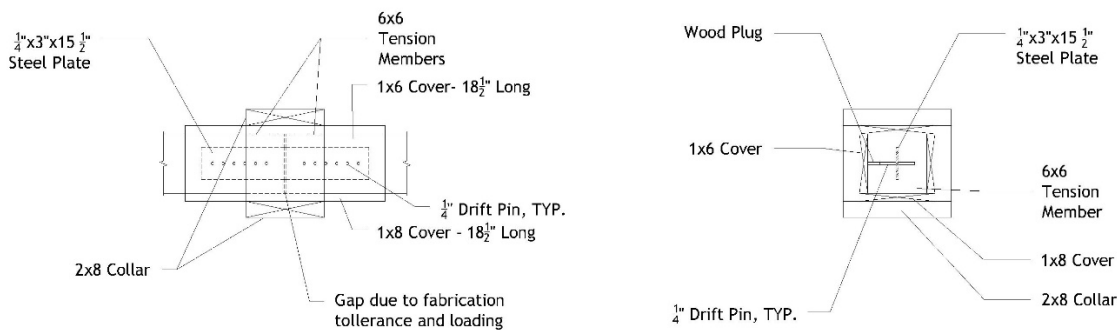

Figure 10-5. Final wood protection design

Protection of Steel Splice Plate and Drift Pins with Type X gypsum wallboard

In lieu of additional wood cover calculated previously, 5/8" Type X gypsum wallboard (GWB) could be used to provide the additional 35.8 minutes of the 1-hr fire resistance. From 4.4.2, one layer of 5/8" Type X GWB would provide an additional 40 minutes of protection. The contribution of the gypsum does not need to be reduced based on provisions of 4.4.2.3, because the gypsum is not the only layer or final layer of protection for the connection. The additional collar could be wood as shown previously, or an additional layer of 5/8" Type X GWB. The two layers of GWB would provide 60 minutes of thermal separation protection at the gap that would likely occur between the abutting ends (40 minutes for the outer layer, 20 minutes for the final layer per Section 4.4.2.3).

Gypsum Board Contraction

The effects of char contraction and GWB contraction may be lessened or mitigated through use of fire-stopping materials such as mineral wool insulation, intumescent tapes and fire sealants. It is up to the designer to determine, in consultation with the fire-stop product manufacturer and the authority having jurisdiction, the applicability of such products and to verify their performance within the assembly by means of test data or other substantiated performance indicators.

References

- [1] Malhotra, H., and Rogowski, F., "Fire-Resistance of Laminated Timber Columns," *Proceedings of Symposium No. 3*, Her Majesty's Stationary Office, London 1970, pp.16-51.
- [2] "ASTM E119-20: Standard Test Methods for Fire Tests of Building Construction and Materials," in *ASTM Test Standards*, Philadelphia, PA, 2020.
- [3] "ISO 834: Fire-Resistance Tests - Elements of Building Construction," International Organization for Standardization, Geneva, Switzerland, 1975.
- [4] Lie, T.T., "A Method for Assessing the Fire Resistance of Laminated Timber Beams and Columns", *Canadian Journal of Civil Engineering*, Vol. 4, 1977, pp.161-169.
- [5] "Design of One-Hour Fire-Resistive Exposed Wood Members," Council of American Building Officials, National Evaluation Board Report No. NRB-250, 1984.
- [6] Fackler, J.P., *Cahiers du CSTB No. 52*, Centre Technique et Scientifique du Bâtiment, Paris, France, 1961.
- [7] Malhotra, H., and Rogowski, F., "Fire-Resistance of Laminated Timber Columns," *Proceedings of Symposium No. 3*, Her Majesty's Stationary Office, London 1970, pp. 16-51.
- [8] Stanke, J., Klement, E., and Rudolphi, R., "Das Brandverhalten von Holzstützen unter Druckbeanspruchung (The Fire Performance of Timber Columns under Compression Load)," *BAM-Berichte Nr. 24*, BAM, Berlin, 1973.
- [9] 2018 *National Design Specification® for Wood Construction - ANSI/AWC NDS-2018*, American Wood Council, Leesburg, VA 2018.
- [10] *Eurocode 5, Part 1.2, Structural Fire Design*, CEN, Brussels, Belgium, 1994.
- [11] "AS 1720 Part 4: Fire Resistance of Structural Timber Members", Standard Association of Australia, North Sydney, Australia, 1985.
- [12] "Development of Firesafety Design Method of Buildings", Ministry of Construction Research Report, Tokyo, Japan, 1988.
- [13] King, E., and Glowinski, R., "A Rationalized Model for Calculating the Fire Endurance of Wood Beams", *Forest Products Journal*, Vol. 38, 1988, pp. 31-36.
- [14] Majamaa, J., "Calculation Models of Fire Exposed Wooden Beams", *Proceedings of the 1991 International Timber Engineering Conference*, Vol. 4, 1991, pp.91-98.
- [15a] "ASTM D245-06(2019): Standard Practice for Establishing Structural Grades and Related Properties for Visually Graded Lumber", ASTM, Philadelphia, PA, 2019.
- [15b] "ASTM D3737-18 Standard Practice for Establishing Allowable Properties for Structural Glued Laminated Timber (Glulam)", ASTM, Philadelphia, PA, 2018.
- [15c] "ASTM D5456-18 Standard Specification for Evaluation of Structural Composite Lumber Products", ASTM, Philadelphia, PA, 2018.
- [16] Hall, G., "Fire Resistance Tests of Laminated Timber Beams," Research Report WT/RR/1, Timber Research and Development Association, High Wycombe, UK, 1968.

- [17] "Report of Standard Fire Endurance Test - Nominal 8-³/₄" by 16-¹/₂" Glulam Wood Beam," Report No. WHI-694-0069, Warnock Hersey International Inc., Severna Park, MD, 1982.
- [18] Syme, D., "Verification of Charring Equations for Australian Timbers Based on Full-Scale Fire Resistance Tests," *Proceedings of the Pacific Timber Engineering Conference*, Gold Coast, Australia, 1994, pp. 619-623.
- [19] Ruger, F., Delafont, C., and El Ouadrani, A., "The Structural Properties of French-Grown Timber According to Various Grading Methods," *Proceedings of CIB W18 Meeting*, Paper #5.
- [20] "Plank and Beam Framing for Residential Buildings," National Forest Products Association, Washington, DC, 1989.
- [21] "Fire Resistance of Heavy Timber and Plywood Roof Constructions," Underwriters' Laboratories File NC495, Chicago, IL, 1964.
- [22] Bletzacker, R., Lane, W., and Denning, D., "Fire Resistance of Construction Assemblies - Volume I," Ohio State University, Columbus, OH, 1969.
- [23] "Evaluation of the Effects of Load on the Fire Resistance of Glulam Beams," SwRI Project No. 01-8641-001, Southwest Research Institute, San Antonio, TX, 1997.
- [24] White, Robert H., "Charring Rates of Different Wood Species," PhD Thesis, University of Wisconsin, Madison, WI, 1988.
- [25] 2001 *National Design Specification[®] for Wood Construction - ANSI/AF&PA NDS-2001*, American Forest & Paper Association, American Wood Council, Washington, DC, 2001.
- [26] Dayeh, R.J. and Syme, D. R. "Behaviour of Glulam Beams in Fire," *Proceedings of Building the Future Seminar*, Institution of Structural Engineers, Brighton, United Kingdom, 1993.
- [27] White, Robert H., "Fire Endurance Tests of Axially Loaded Timber Tension Members," U.S. Forest Products Laboratory, U.S. Department of Agriculture, Madison, WI, 2001.
- [28] Son, B. C. "Fire Endurance Tests of Unprotected Wood-Floor Constructions for Single-Family Residences", National Bureau of Standards Report 10-320, May 10, 1971.
- [29] *American Softwood Lumber Standard*, NBS Voluntary Product Standard, PS20-70, U.S. Department of Commerce, 1970.
- [30] Factory Mutual Research. FC 209 "ASTM E119-73 Fire Endurance Test: Floor Assembly 2 by 10 in. Wood Joists, 23/32 in. Plywood Deck and Vinyl Tile Flooring", June 20, 1974.
- [31] Factory Mutual Research. FC 212 "ASTM E119-73 Fire Endurance Test: Floor Assembly 2 by 10 in. Wood Joists, 23/32 in. Plywood Deck and Nylon Carpet Flooring", July 17, 1974.
- [32] Factory Mutual Research. FC 213 "ASTM E119-73 Fire Endurance Test: Floor Assembly 2 by 8 in. Wood Joists, 19/32 in. Plywood Deck and Vinyl Tile Flooring", June 20, 1974.
- [33] Factory Mutual Research. FC 212 "ASTM E119-73 Fire Endurance Test: Floor Assembly 2 by 8 in. Wood Joists, 19/32 in. Plywood Deck and Nylon Carpet Flooring", July 17, 1974.

- [34] National Bureau of Standards. NBSIR 82-2488 “*Fire Endurance Tests of Selected Residential Floor Construction*”, April 1982.
- [35] White, Robert H., Schaffer, E.L., and Woeste, F.E. “Replicate Fire Endurance Tests of an Unprotected Wood Joist Floor Assembly”, *Wood and Fiber Science*, 16(3), 1984, pp. 374-390.
- [36] Douglas, Bradford K. and Robert H. White. “Feasibility Study of NFPA System 1 as a Fire Endurance Model”, Proceedings of the 1990 ASCE Structures Congress. June 1990.
- [37] Grundahl, Kirk. *National Engineered Lightweight Construction Fire Research Project Technical Report*. National Fire Protection Research Foundation. October 1992, pp. 86-88.
- [38] Underwriters Laboratory. “Report on Structural Stability of Engineered Lumber in Fire Conditions”. NC9140. September 30, 2008.
- [39] Kerber, Steve, Samuels, M, Backstrom, and B, Dalton, J. “Fire Service Collapse Hazard Floor Furnace Experiments”, Underwriters Laboratory, January 2011.
- [40] *1944 National Design Specification for Stress-Grade Lumber and Its Fastenings*, National Lumber Manufacturers Association, American Wood Council, Washington, DC, 1944.
- [41] ASTM D 5456 – 13a: “Standard Specification for Evaluation of Structural Composite Lumber Products,” ASTM, Philadelphia, PA. 2013.
- [42] White, Robert H., “Fire Resistance of Structural Composite Lumber Products”, FPL-RP-633. U.S. Forest Products Laboratory, U.S. Department of Agriculture, Madison, WI. April 2006.
- [43] “Fire Resistance Testing of Structural Composite Lumber Single Beams”, WFCi Report #14035. Western Fire Center, Inc. 2204 Parrott Way, Kelso, WA. July 28, 2014.
- [44] Noack and Dr. Weche, Ing. “Testing of 2x2 wood beams, length 5000 mm, measuring b_xh=100/100 and 115/488 out of veneer strand lumber ‘Parallam PSL’ under loading for fire behavior at trilateral fire stress according to DIN 4102 part 2”, Institute for Building Materials, Massive Type of Construction and Fire Protection at the Technical University Braunschweig, Germany. April 26, 1994.
- [45] DIN 4102-2 “Fire Behaviour of Building Materials and Building Components”, Deutsches Institut für Normung, Germany. 1977.
- [46] Garabedian, A. and Janssens, M.L. “Evaluation of the Char Rate and Structural Performance of Parallam[®] PSL Beams Exposed to Fire”, SWRi Report 01-1046-001, Southwest Research Institute, San Antonio, TX. August 1997.
- [47] Noack and Dr. Weche, Ing. “Testing of two loaded supports made of parallel strand lumber ‘Parallam PSL’ in regard to fire behavior at quadrilateral fire stresses according to DIN 4102 part 2”, Institute for Building Materials, Massive Type of Construction and Fire Protection at the Technical University Braunschweig, Germany. May 13, 1994.
- [48] Kodur, V.K.R., Latour, J.C., and MacLaurin, J.W. “Fire Resistance Test on a Parallam[®] PSL Column”, NRC Report A-0117.1, National Research Council, Ontario, Canada. October 30, 1997.
- [49] CAN/ULC S101, “Standard Methods of Fire Endurance Tests of Building Construction and Materials”, Underwriters’ Laboratories of Canada, Scarborough, ON. 1989

- [50] Osborne, Lindsay, Dagenais, C and Benichou, N. “Preliminary CLT Fire Resistance Testing Report (Project No. 301006155)”, FPInnovations, July 2012.
- [51] ANSI/APA PRG 320-19 “Standard for Performance-Rated Cross-Laminated Timber”, APA – *The Engineered Wood Association*, 7011 South 19th Street, Tacoma, WA. 2019.
- [52] “Report of Testing A Load-Bearing Wall Assembly of Cross-Laminated Timber (CLT) Panels”, Intertek Report Number 100668113SAT-002A, Intertek Evaluation Center, 16015 Shady Falls Road, Elmendorf, TX. May 25, 2012.
- [53] Design for Code Acceptance (DCA) 4 - Component Additive Method (CAM) for Calculating and Demonstrating Assembly Fire Resistance. American Wood Council, Leesburg, VA. 2014.
- [54] Design for Code Acceptance (DCA) 3 - Fire-Resistance-Rated Wood Floor and Wall Assemblies. American Wood Council, Leesburg, VA. February 2020.
- [55] “Load Bearing Partition, Wood Studs Faced with Plywood Paneling and Gypsum Wallboard”, Design WP 351, Factory Mutual Research, Norwood, MA. June 20, 1974.
- [56] White, R. and Cramer, S. “Improving the Fire Endurance of Wood Truss Systems”, Pacific Timber Engineering Conference, Gold Coast Australia, 1993.
- [57] White, Robert H. “Fire Resistance of Engineered Wood Rim Board Products”, Research Paper FPL-RP-610, U.S. Forest Products Laboratory, U.S. Department of Agriculture, Madison, WI, May 2003.
- [58] “Cross-Laminated Timber and Gypsum Board Wall Assembly (Load-Bearing)”, WP-1950, NGC Testing Services, Buffalo, NY, October 15, 2012.
- [59] “Fire Resistance Testing of CLT Floor/Ceiling Assemblies to Establish Contribution of Gypsum Protection”, WFCi Report #17091r1, NGC Testing Services, Buffalo, NY, October 15, 2012.”, WP-1950, Western Fire Center Inc., Kelso, WA, November 28, 2017.
- [60] SmartLam Cross-Laminated Timber, APA Product Report PR-L319, APA – The Engineered Wood Association, Takoma, WA, April 15, 2016.
- [61] White, Robert H. “Tensile Strength of Fire-Exposed Wood Members”, Proceedings of the International Wood Engineering Conference, New Orleans, Oct. 28-31, 1996, pp. 2-385 to 2-390.
- [62] DIN 1052-1:1969 “Timber structures; design and construction”, Ausgabe, 1969.
- [63] *Technical Report 10: Calculating the Fire Resistance of Exposed Wood Members*, TR10, American Forest & Paper Association, Washington, DC, 1999.
- [64] “ASTM D7247 - 07a Standard Test Method for Evaluating the Shear Strength of Adhesive Bonds in Laminated Wood Products at Elevated Temperatures”, ASTM, Philadelphia, PA, 2007.

APPENDIX A: Derivation of Load Ratio Tables

For members stressed in one principal direction, simplifications can be made which allow the tabulation of load factor tables. These load factor tables can be used to determine the structural design load ratio, R_s , at which the member has sufficient capacity for a given fire endurance time. This appendix provides load ratio tables and the rationale used to develop those tables. For more complex calculations where stress interactions must be considered, the user should consider using the provisions of this technical report along with appropriate *NDS* provisions.

Bending Members

$$\text{Structural: } D+L \leq R_s F_b S_s C_{L-s} C_D C_M C_t$$

$$\text{Fire: } D+L \leq 2.85 F_b S_f C_{L-f}$$

Where;

- D = Design dead load
- L = Design live load
- R_s = Design load ratio
- F_b = Tabulated bending design value
- S_s = Section modulus using full (initial) cross-section dimensions
- S_f = Section modulus using cross-section dimensions reduced from fire exposure
- C_{L-s} = Beam Stability factor using full cross-section dimensions
- C_{L-f} = Beam Stability factor using cross-section dimensions reduced from fire exposure
- C_D = Load Duration factor
- C_M = Wet Service factor
- C_t = Temperature factor

Solve for R_s :

$$R_s = \frac{2.85 S_f C_{L-f}}{S_s C_{L-s} C_D C_M C_t}$$

For cases in which the compression edge does not have continuous lateral support, a beam stability factor must be calculated separately for both the full (initial) cross-sectional dimensions (C_{L-s}) and for the cross-sectional dimensions reduced from fire exposure (C_{L-f}). The calculation of C_{L-s} and C_{L-f} require the designer to consider both the change in bending section relative to bending strength and the change in buckling stiffness relative to buckling strength. While these relationships can be directly calculated using *NDS* provisions, they cannot be easily tabulated. However, for most beams exposed on three-sides, the beams are braced on the protected side.

Design load ratios, R_s , for fire design of flexural members are given in Table A1(1-hr), Table A1(1.5-hr) and Table A1(2-hr) for 1-hour, 1.5-hour and 2-hour fire-resistance ratings, respectively. These values were developed for standard reference conditions ($C_D=1.0$; $C_M=1.0$; $C_t=1.0$; $C_{L-f}=1.0$), assuming three-sided exposure (protected from fire exposure along the top face), and continuous lateral support along the compression edge of the beam. The dimension “d” is the actual cross-sectional dimension measured in the direction normal to the axis about which bending occurs, and is not necessarily greater than “b” (see Figure A1).

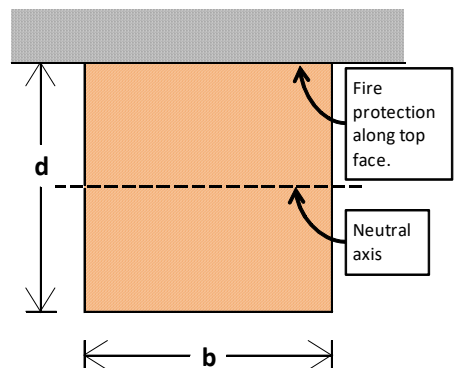

Figure A1

Table A1(1-hr) Design Load Ratios, R_s , for Flexural Members Exposed on Three Sides
1 – HOUR RATING (Structural Calculations at Standard Reference Conditions: $C_D=1.0$, $C_M=1.0$, $C_t=1.0$, $C_i=1.0$, $C_L=1.0$)
 (Protected Surface Along Width, b , on Top Edge; With Continuous Lateral Support)

Width, b	5 1/2	6	6 3/4	6 7/8	7 1/4	7 1/2	8 1/4	8 1/2	8 3/4	9	9 1/4	9 5/8	10 1/2	10 3/4	11	11 1/4	12	12 1/4	12 3/8	13 1/4	13 1/2	13 3/4	15
Depth, d	Design Load Ratio, R_s																						
5 1/2	0.45	0.52	0.60	0.61	0.65	0.67	0.73	0.74	0.76	0.77	0.79	0.81	0.85	0.86	0.87	0.88	0.90	0.91	0.91	0.94	0.95	0.95	0.98
6	0.48	0.56	0.65	0.67	0.70	0.73	0.79	0.81	0.82	0.84	0.85	0.87	0.92	0.93	0.94	0.95	0.98	0.99	0.99	1.00	1.00	1.00	1.00
6 3/4	0.53	0.61	0.72	0.73	0.77	0.80	0.86	0.88	0.90	0.92	0.94	0.96	1.00	1.00	1.00	1.00	1.00	1.00	1.00	1.00	1.00	1.00	1.00
6 7/8	0.54	0.62	0.72	0.74	0.78	0.81	0.88	0.90	0.91	0.93	0.95	0.97	1.00	1.00	1.00	1.00	1.00	1.00	1.00	1.00	1.00	1.00	1.00
7 1/4	0.56	0.64	0.75	0.77	0.81	0.84	0.91	0.93	0.95	0.97	0.98	1.00	1.00	1.00	1.00	1.00	1.00	1.00	1.00	1.00	1.00	1.00	1.00
7 1/2	0.57	0.66	0.77	0.78	0.83	0.86	0.93	0.95	0.97	0.99	1.00	1.00	1.00	1.00	1.00	1.00	1.00	1.00	1.00	1.00	1.00	1.00	1.00
8 1/4	0.60	0.70	0.81	0.83	0.88	0.91	0.98	1.00	1.00	1.00	1.00	1.00	1.00	1.00	1.00	1.00	1.00	1.00	1.00	1.00	1.00	1.00	1.00
8 1/2	0.61	0.71	0.83	0.84	0.89	0.92	1.00	1.00	1.00	1.00	1.00	1.00	1.00	1.00	1.00	1.00	1.00	1.00	1.00	1.00	1.00	1.00	1.00
8 3/4	0.62	0.72	0.84	0.86	0.91	0.93	1.00	1.00	1.00	1.00	1.00	1.00	1.00	1.00	1.00	1.00	1.00	1.00	1.00	1.00	1.00	1.00	1.00
9	0.63	0.73	0.85	0.87	0.92	0.95	1.00	1.00	1.00	1.00	1.00	1.00	1.00	1.00	1.00	1.00	1.00	1.00	1.00	1.00	1.00	1.00	1.00
9 1/4	0.64	0.74	0.86	0.88	0.93	0.96	1.00	1.00	1.00	1.00	1.00	1.00	1.00	1.00	1.00	1.00	1.00	1.00	1.00	1.00	1.00	1.00	1.00
9 5/8	0.65	0.75	0.88	0.90	0.95	0.98	1.00	1.00	1.00	1.00	1.00	1.00	1.00	1.00	1.00	1.00	1.00	1.00	1.00	1.00	1.00	1.00	1.00
10 1/2	0.68	0.78	0.91	0.93	0.99	1.00	1.00	1.00	1.00	1.00	1.00	1.00	1.00	1.00	1.00	1.00	1.00	1.00	1.00	1.00	1.00	1.00	1.00
10 3/4	0.68	0.79	0.92	0.94	0.99	1.00	1.00	1.00	1.00	1.00	1.00	1.00	1.00	1.00	1.00	1.00	1.00	1.00	1.00	1.00	1.00	1.00	1.00
11	0.69	0.80	0.93	0.95	1.00	1.00	1.00	1.00	1.00	1.00	1.00	1.00	1.00	1.00	1.00	1.00	1.00	1.00	1.00	1.00	1.00	1.00	1.00
11 1/4	0.69	0.80	0.94	0.96	1.00	1.00	1.00	1.00	1.00	1.00	1.00	1.00	1.00	1.00	1.00	1.00	1.00	1.00	1.00	1.00	1.00	1.00	1.00
12	0.71	0.82	0.96	0.98	1.00	1.00	1.00	1.00	1.00	1.00	1.00	1.00	1.00	1.00	1.00	1.00	1.00	1.00	1.00	1.00	1.00	1.00	1.00
12 1/4	0.72	0.83	0.97	0.99	1.00	1.00	1.00	1.00	1.00	1.00	1.00	1.00	1.00	1.00	1.00	1.00	1.00	1.00	1.00	1.00	1.00	1.00	1.00
12 3/8	0.72	0.83	0.97	0.99	1.00	1.00	1.00	1.00	1.00	1.00	1.00	1.00	1.00	1.00	1.00	1.00	1.00	1.00	1.00	1.00	1.00	1.00	1.00
13 1/4	0.74	0.85	0.99	1.00	1.00	1.00	1.00	1.00	1.00	1.00	1.00	1.00	1.00	1.00	1.00	1.00	1.00	1.00	1.00	1.00	1.00	1.00	1.00
13 1/2	0.74	0.86	1.00	1.00	1.00	1.00	1.00	1.00	1.00	1.00	1.00	1.00	1.00	1.00	1.00	1.00	1.00	1.00	1.00	1.00	1.00	1.00	1.00
13 3/4	0.74	0.86	1.00	1.00	1.00	1.00	1.00	1.00	1.00	1.00	1.00	1.00	1.00	1.00	1.00	1.00	1.00	1.00	1.00	1.00	1.00	1.00	1.00
15	0.76	0.88	1.00	1.00	1.00	1.00	1.00	1.00	1.00	1.00	1.00	1.00	1.00	1.00	1.00	1.00	1.00	1.00	1.00	1.00	1.00	1.00	1.00
15 1/8	0.76	0.88	1.00	1.00	1.00	1.00	1.00	1.00	1.00	1.00	1.00	1.00	1.00	1.00	1.00	1.00	1.00	1.00	1.00	1.00	1.00	1.00	1.00
16 1/2	0.78	0.90	1.00	1.00	1.00	1.00	1.00	1.00	1.00	1.00	1.00	1.00	1.00	1.00	1.00	1.00	1.00	1.00	1.00	1.00	1.00	1.00	1.00
17	0.79	0.91	1.00	1.00	1.00	1.00	1.00	1.00	1.00	1.00	1.00	1.00	1.00	1.00	1.00	1.00	1.00	1.00	1.00	1.00	1.00	1.00	1.00
17 7/8	0.80	0.92	1.00	1.00	1.00	1.00	1.00	1.00	1.00	1.00	1.00	1.00	1.00	1.00	1.00	1.00	1.00	1.00	1.00	1.00	1.00	1.00	1.00
18	0.80	0.92	1.00	1.00	1.00	1.00	1.00	1.00	1.00	1.00	1.00	1.00	1.00	1.00	1.00	1.00	1.00	1.00	1.00	1.00	1.00	1.00	1.00
19	0.81	0.93	1.00	1.00	1.00	1.00	1.00	1.00	1.00	1.00	1.00	1.00	1.00	1.00	1.00	1.00	1.00	1.00	1.00	1.00	1.00	1.00	1.00
19 1/4	0.81	0.94	1.00	1.00	1.00	1.00	1.00	1.00	1.00	1.00	1.00	1.00	1.00	1.00	1.00	1.00	1.00	1.00	1.00	1.00	1.00	1.00	1.00
19 1/2	0.81	0.94	1.00	1.00	1.00	1.00	1.00	1.00	1.00	1.00	1.00	1.00	1.00	1.00	1.00	1.00	1.00	1.00	1.00	1.00	1.00	1.00	1.00
20 5/8	0.82	0.95	1.00	1.00	1.00	1.00	1.00	1.00	1.00	1.00	1.00	1.00	1.00	1.00	1.00	1.00	1.00	1.00	1.00	1.00	1.00	1.00	1.00
21	0.82	0.95	1.00	1.00	1.00	1.00	1.00	1.00	1.00	1.00	1.00	1.00	1.00	1.00	1.00	1.00	1.00	1.00	1.00	1.00	1.00	1.00	1.00
22	0.83	0.96	1.00	1.00	1.00	1.00	1.00	1.00	1.00	1.00	1.00	1.00	1.00	1.00	1.00	1.00	1.00	1.00	1.00	1.00	1.00	1.00	1.00
22 1/2	0.83	0.96	1.00	1.00	1.00	1.00	1.00	1.00	1.00	1.00	1.00	1.00	1.00	1.00	1.00	1.00	1.00	1.00	1.00	1.00	1.00	1.00	1.00
23	0.84	0.97	1.00	1.00	1.00	1.00	1.00	1.00	1.00	1.00	1.00	1.00	1.00	1.00	1.00	1.00	1.00	1.00	1.00	1.00	1.00	1.00	1.00
23 3/8	0.84	0.97	1.00	1.00	1.00	1.00	1.00	1.00	1.00	1.00	1.00	1.00	1.00	1.00	1.00	1.00	1.00	1.00	1.00	1.00	1.00	1.00	1.00
24	0.84	0.98	1.00	1.00	1.00	1.00	1.00	1.00	1.00	1.00	1.00	1.00	1.00	1.00	1.00	1.00	1.00	1.00	1.00	1.00	1.00	1.00	1.00
30	0.87	1.00	1.00	1.00	1.00	1.00	1.00	1.00	1.00	1.00	1.00	1.00	1.00	1.00	1.00	1.00	1.00	1.00	1.00	1.00	1.00	1.00	1.00
36	0.89	1.00	1.00	1.00	1.00	1.00	1.00	1.00	1.00	1.00	1.00	1.00	1.00	1.00	1.00	1.00	1.00	1.00	1.00	1.00	1.00	1.00	1.00
60	0.93	1.00	1.00	1.00	1.00	1.00	1.00	1.00	1.00	1.00	1.00	1.00	1.00	1.00	1.00	1.00	1.00	1.00	1.00	1.00	1.00	1.00	1.00

1. Design load ratios (R_s) assume bending about the X-X axis, and continuous lateral support along the compression edge.
2. Design load ratios (R_s) may be interpolated for depths (d) other than those shown.
3. For the purposes of this table, the dimension d is measured in the direction normal to the axis about which bending occurs. The dimensions d and b are dressed, dry dimensions.
4. The design moment for fire, $F_{b,f}S_f$, is approximated by multiplying the adjusted ASD design moment used in structural design, $F_b'S$, by R_s . ($F_{b,f}S_f = F_b'S R_s$)

Table A1(1.5-hr) Design Load Ratios, R_s , for Flexural Members Exposed on Three Sides

1.5 – HOUR RATING (Structural Calculations at Standard Reference Conditions: $C_D=1.0$, $C_M=1.0$, $C_t=1.0$, $C_i=1.0$, $C_L=1.0$)
 (Protected Surface Along Width, b , on Top Edge; With Continuous Lateral Support)

Width, b	6 3/4	6 7/8	7 1/4	7 1/2	8 1/4	8 1/2	8 3/4	9	9 1/4	9 5/8	10 1/2	10 3/4	11	11 1/4	12	12 3/8	13 1/4	13 3/4	15	16 1/2	18	24	36
Depth, d	Design Load Ratio, R_s																						
5 1/2	0.22	0.23	0.26	0.28	0.33	0.35	0.36	0.38	0.39	0.41	0.44	0.45	0.46	0.47	0.49	0.50	0.53	0.54	0.56	0.59	0.61	0.67	0.73
6	0.25	0.26	0.30	0.32	0.38	0.40	0.41	0.43	0.44	0.46	0.51	0.52	0.53	0.54	0.56	0.58	0.60	0.62	0.65	0.67	0.70	0.77	0.83
6 3/4	0.29	0.31	0.35	0.38	0.44	0.46	0.48	0.50	0.52	0.54	0.59	0.60	0.61	0.63	0.66	0.67	0.70	0.72	0.75	0.79	0.81	0.89	0.97
6 7/8	0.30	0.31	0.36	0.38	0.45	0.47	0.49	0.51	0.53	0.55	0.60	0.62	0.63	0.64	0.67	0.69	0.72	0.73	0.77	0.80	0.83	0.91	0.99
7 1/4	0.32	0.33	0.38	0.41	0.48	0.50	0.52	0.54	0.56	0.59	0.64	0.65	0.67	0.68	0.71	0.73	0.76	0.78	0.81	0.85	0.88	0.97	1.00
7 1/2	0.33	0.34	0.39	0.42	0.50	0.52	0.54	0.56	0.58	0.61	0.66	0.68	0.69	0.70	0.74	0.75	0.79	0.80	0.84	0.88	0.91	1.00	1.00
8 1/4	0.36	0.38	0.43	0.46	0.54	0.57	0.59	0.61	0.63	0.66	0.72	0.74	0.75	0.77	0.81	0.82	0.86	0.88	0.92	0.96	1.00	1.00	1.00
8 1/2	0.37	0.39	0.44	0.47	0.56	0.58	0.61	0.63	0.65	0.68	0.74	0.76	0.77	0.79	0.83	0.84	0.88	0.90	0.95	0.99	1.00	1.00	1.00
8 3/4	0.38	0.40	0.45	0.48	0.57	0.60	0.62	0.64	0.67	0.70	0.76	0.78	0.79	0.81	0.85	0.87	0.90	0.92	0.97	1.00	1.00	1.00	1.00
9	0.38	0.40	0.46	0.49	0.58	0.61	0.64	0.66	0.68	0.71	0.78	0.79	0.81	0.82	0.87	0.88	0.92	0.94	0.99	1.00	1.00	1.00	1.00
9 1/4	0.39	0.41	0.47	0.50	0.60	0.62	0.65	0.67	0.70	0.73	0.79	0.81	0.83	0.84	0.88	0.90	0.94	0.96	1.00	1.00	1.00	1.00	1.00
9 5/8	0.40	0.42	0.48	0.52	0.61	0.64	0.67	0.69	0.72	0.75	0.82	0.83	0.85	0.87	0.91	0.93	0.97	0.99	1.00	1.00	1.00	1.00	1.00
10 1/2	0.43	0.45	0.51	0.55	0.65	0.68	0.71	0.73	0.76	0.79	0.87	0.88	0.90	0.92	0.96	0.98	1.00	1.00	1.00	1.00	1.00	1.00	1.00
10 3/4	0.43	0.46	0.52	0.56	0.66	0.69	0.72	0.74	0.77	0.81	0.88	0.90	0.91	0.93	0.98	1.00	1.00	1.00	1.00	1.00	1.00	1.00	1.00
11	0.44	0.46	0.53	0.57	0.67	0.70	0.73	0.75	0.78	0.82	0.89	0.91	0.93	0.94	0.99	1.00	1.00	1.00	1.00	1.00	1.00	1.00	1.00
11 1/4	0.45	0.47	0.53	0.57	0.68	0.71	0.74	0.76	0.79	0.83	0.90	0.92	0.94	0.96	1.00	1.00	1.00	1.00	1.00	1.00	1.00	1.00	1.00
12	0.46	0.49	0.55	0.59	0.70	0.73	0.76	0.79	0.82	0.86	0.93	0.95	0.97	0.99	1.00	1.00	1.00	1.00	1.00	1.00	1.00	1.00	1.00
12 1/4	0.47	0.49	0.56	0.60	0.71	0.74	0.77	0.80	0.83	0.87	0.94	0.96	0.98	1.00	1.00	1.00	1.00	1.00	1.00	1.00	1.00	1.00	1.00
12 3/8	0.47	0.49	0.56	0.60	0.71	0.75	0.78	0.80	0.83	0.87	0.95	0.97	0.99	1.00	1.00	1.00	1.00	1.00	1.00	1.00	1.00	1.00	1.00
13 1/4	0.48	0.51	0.58	0.62	0.74	0.77	0.80	0.83	0.86	0.90	0.98	1.00	1.00	1.00	1.00	1.00	1.00	1.00	1.00	1.00	1.00	1.00	1.00
13 1/2	0.49	0.51	0.59	0.63	0.74	0.78	0.81	0.84	0.87	0.91	0.99	1.00	1.00	1.00	1.00	1.00	1.00	1.00	1.00	1.00	1.00	1.00	1.00
13 3/4	0.49	0.52	0.59	0.63	0.75	0.78	0.82	0.85	0.87	0.92	1.00	1.00	1.00	1.00	1.00	1.00	1.00	1.00	1.00	1.00	1.00	1.00	1.00
15	0.51	0.54	0.61	0.66	0.78	0.81	0.85	0.88	0.91	0.95	1.00	1.00	1.00	1.00	1.00	1.00	1.00	1.00	1.00	1.00	1.00	1.00	1.00
15 1/8	0.51	0.54	0.61	0.66	0.78	0.82	0.85	0.88	0.91	0.95	1.00	1.00	1.00	1.00	1.00	1.00	1.00	1.00	1.00	1.00	1.00	1.00	1.00
16 1/2	0.53	0.56	0.63	0.68	0.81	0.84	0.88	0.91	0.94	0.98	1.00	1.00	1.00	1.00	1.00	1.00	1.00	1.00	1.00	1.00	1.00	1.00	1.00
17	0.54	0.56	0.64	0.69	0.82	0.85	0.89	0.92	0.95	0.99	1.00	1.00	1.00	1.00	1.00	1.00	1.00	1.00	1.00	1.00	1.00	1.00	1.00
17 7/8	0.54	0.57	0.65	0.70	0.83	0.87	0.90	0.94	0.97	1.00	1.00	1.00	1.00	1.00	1.00	1.00	1.00	1.00	1.00	1.00	1.00	1.00	1.00
18	0.55	0.57	0.65	0.70	0.83	0.87	0.90	0.94	0.97	1.00	1.00	1.00	1.00	1.00	1.00	1.00	1.00	1.00	1.00	1.00	1.00	1.00	1.00
19	0.56	0.58	0.67	0.71	0.84	0.88	0.92	0.95	0.99	1.00	1.00	1.00	1.00	1.00	1.00	1.00	1.00	1.00	1.00	1.00	1.00	1.00	1.00
19 1/4	0.56	0.59	0.67	0.72	0.85	0.89	0.92	0.96	0.99	1.00	1.00	1.00	1.00	1.00	1.00	1.00	1.00	1.00	1.00	1.00	1.00	1.00	1.00
19 1/2	0.56	0.59	0.67	0.72	0.85	0.89	0.93	0.96	0.99	1.00	1.00	1.00	1.00	1.00	1.00	1.00	1.00	1.00	1.00	1.00	1.00	1.00	1.00
20 5/8	0.57	0.60	0.68	0.73	0.87	0.90	0.94	0.98	1.00	1.00	1.00	1.00	1.00	1.00	1.00	1.00	1.00	1.00	1.00	1.00	1.00	1.00	1.00
21	0.57	0.60	0.68	0.74	0.87	0.91	0.95	0.98	1.00	1.00	1.00	1.00	1.00	1.00	1.00	1.00	1.00	1.00	1.00	1.00	1.00	1.00	1.00
22	0.58	0.61	0.69	0.74	0.88	0.92	0.96	0.99	1.00	1.00	1.00	1.00	1.00	1.00	1.00	1.00	1.00	1.00	1.00	1.00	1.00	1.00	1.00
22 1/2	0.58	0.61	0.70	0.75	0.89	0.93	0.96	1.00	1.00	1.00	1.00	1.00	1.00	1.00	1.00	1.00	1.00	1.00	1.00	1.00	1.00	1.00	1.00
23	0.58	0.62	0.70	0.75	0.89	0.93	0.97	1.00	1.00	1.00	1.00	1.00	1.00	1.00	1.00	1.00	1.00	1.00	1.00	1.00	1.00	1.00	1.00
23 3/8	0.59	0.62	0.70	0.76	0.89	0.93	0.97	1.00	1.00	1.00	1.00	1.00	1.00	1.00	1.00	1.00	1.00	1.00	1.00	1.00	1.00	1.00	1.00
24	0.59	0.62	0.71	0.76	0.90	0.94	0.98	1.00	1.00	1.00	1.00	1.00	1.00	1.00	1.00	1.00	1.00	1.00	1.00	1.00	1.00	1.00	1.00
30	0.62	0.65	0.74	0.80	0.94	0.98	1.00	1.00	1.00	1.00	1.00	1.00	1.00	1.00	1.00	1.00	1.00	1.00	1.00	1.00	1.00	1.00	1.00
36	0.64	0.67	0.76	0.82	0.97	1.00	1.00	1.00	1.00	1.00	1.00	1.00	1.00	1.00	1.00	1.00	1.00	1.00	1.00	1.00	1.00	1.00	1.00
60	0.68	0.71	0.81	0.87	1.00	1.00	1.00	1.00	1.00	1.00	1.00	1.00	1.00	1.00	1.00	1.00	1.00	1.00	1.00	1.00	1.00	1.00	1.00

1. Design load ratios (R_s) assume bending about the X-X axis, and continuous lateral support along the compression edge.
2. Design load ratios (R_s) may be interpolated for depths (d) other than those shown.
3. For the purposes of this table, the dimension d is measured in the direction normal to the axis about which bending occurs. The dimensions d and b are dressed, dry dimensions.
4. The design moment for fire, $F_{b,f}S_f$, is approximated by multiplying the adjusted ASD design moment used in structural design, $F_b'S$, by R_s . ($F_{b,f}S_f = F_b'S R_s$)

Table A1(2-hr) Design Load Ratios, R_s , for Flexural Members Exposed on Three Sides
2 – HOUR RATING (Structural Calculations at Standard Reference Conditions: $C_D=1.0$, $C_M=1.0$, $C_t=1.0$, $C_i=1.0$, $C_L=1.0$)
 (Protected Surface Along Width, b , on Top Edge; With Continuous Lateral Support)

Width, b	8 1/2	8 3/4	9	9 1/4	9 5/8	10 1/2	10 3/4	11	11 1/4	12	12 3/8	13 1/4	13 1/2	13 3/4	15	16 1/2	17	18	21	24	36	48	60
Depth, d	Design Load Ratio, R_s																						
5 1/2	0.13	0.14	0.15	0.16	0.18	0.20	0.21	0.22	0.23	0.24	0.25	0.27	0.27	0.28	0.30	0.32	0.32	0.33	0.36	0.38	0.42	0.45	0.46
6	0.16	0.18	0.19	0.20	0.22	0.25	0.26	0.27	0.28	0.30	0.31	0.33	0.34	0.34	0.37	0.39	0.40	0.41	0.45	0.47	0.53	0.55	0.57
6 3/4	0.21	0.22	0.24	0.25	0.28	0.32	0.33	0.34	0.35	0.38	0.39	0.42	0.43	0.43	0.47	0.50	0.51	0.52	0.56	0.59	0.66	0.70	0.72
6 7/8	0.21	0.23	0.25	0.26	0.28	0.33	0.34	0.35	0.36	0.39	0.41	0.43	0.44	0.45	0.48	0.51	0.52	0.54	0.58	0.61	0.69	0.72	0.74
7 1/4	0.23	0.25	0.27	0.29	0.31	0.36	0.37	0.39	0.40	0.43	0.44	0.47	0.48	0.49	0.52	0.56	0.57	0.59	0.63	0.67	0.75	0.79	0.81
7 1/2	0.24	0.26	0.28	0.30	0.33	0.38	0.39	0.41	0.42	0.45	0.47	0.50	0.51	0.51	0.55	0.59	0.60	0.62	0.67	0.70	0.79	0.83	0.85
8 1/4	0.28	0.30	0.32	0.34	0.37	0.43	0.45	0.46	0.47	0.51	0.53	0.57	0.58	0.59	0.63	0.67	0.68	0.70	0.76	0.80	0.89	0.94	0.97
8 1/2	0.29	0.31	0.33	0.36	0.39	0.45	0.46	0.48	0.49	0.53	0.55	0.59	0.60	0.61	0.65	0.69	0.71	0.73	0.79	0.83	0.93	0.98	1.00
8 3/4	0.30	0.32	0.35	0.37	0.40	0.46	0.48	0.49	0.51	0.55	0.57	0.61	0.62	0.63	0.67	0.72	0.73	0.75	0.81	0.86	0.96	1.00	1.00
9	0.31	0.33	0.36	0.38	0.41	0.48	0.49	0.51	0.52	0.57	0.59	0.63	0.64	0.65	0.69	0.74	0.75	0.78	0.84	0.88	0.99	1.00	1.00
9 1/4	0.32	0.34	0.37	0.39	0.42	0.49	0.51	0.52	0.54	0.58	0.60	0.65	0.66	0.67	0.71	0.76	0.78	0.80	0.86	0.91	1.00	1.00	1.00
9 5/8	0.33	0.36	0.38	0.41	0.44	0.51	0.53	0.55	0.56	0.61	0.63	0.67	0.68	0.69	0.74	0.79	0.81	0.83	0.90	0.95	1.00	1.00	1.00
10 1/2	0.36	0.39	0.41	0.44	0.48	0.55	0.57	0.59	0.61	0.66	0.68	0.73	0.74	0.75	0.80	0.86	0.87	0.90	0.97	1.00	1.00	1.00	1.00
10 3/4	0.36	0.39	0.42	0.45	0.49	0.56	0.58	0.60	0.62	0.67	0.69	0.74	0.75	0.77	0.82	0.88	0.89	0.92	0.99	1.00	1.00	1.00	1.00
11	0.37	0.40	0.43	0.46	0.50	0.58	0.60	0.61	0.63	0.68	0.71	0.76	0.77	0.78	0.84	0.89	0.91	0.94	1.00	1.00	1.00	1.00	1.00
11 1/4	0.38	0.41	0.44	0.47	0.51	0.59	0.61	0.63	0.64	0.70	0.72	0.77	0.78	0.80	0.85	0.91	0.92	0.96	1.00	1.00	1.00	1.00	1.00
12	0.40	0.43	0.46	0.49	0.53	0.61	0.64	0.66	0.68	0.73	0.76	0.81	0.82	0.83	0.89	0.95	0.97	1.00	1.00	1.00	1.00	1.00	1.00
12 1/4	0.40	0.43	0.47	0.50	0.54	0.62	0.65	0.67	0.69	0.74	0.77	0.82	0.83	0.85	0.91	0.97	0.98	1.00	1.00	1.00	1.00	1.00	1.00
12 3/8	0.40	0.44	0.47	0.50	0.54	0.63	0.65	0.67	0.69	0.75	0.77	0.83	0.84	0.85	0.91	0.97	0.99	1.00	1.00	1.00	1.00	1.00	1.00
13 1/4	0.42	0.46	0.49	0.52	0.57	0.66	0.68	0.70	0.72	0.78	0.81	0.86	0.88	0.89	0.96	1.00	1.00	1.00	1.00	1.00	1.00	1.00	1.00
13 1/2	0.43	0.46	0.50	0.53	0.57	0.66	0.69	0.71	0.73	0.79	0.82	0.87	0.89	0.90	0.97	1.00	1.00	1.00	1.00	1.00	1.00	1.00	1.00
13 3/4	0.43	0.47	0.50	0.53	0.58	0.67	0.70	0.72	0.74	0.80	0.83	0.88	0.90	0.91	0.98	1.00	1.00	1.00	1.00	1.00	1.00	1.00	1.00
15	0.45	0.49	0.53	0.56	0.61	0.71	0.73	0.75	0.78	0.84	0.87	0.93	0.94	0.96	1.00	1.00	1.00	1.00	1.00	1.00	1.00	1.00	1.00
15 1/8	0.46	0.49	0.53	0.56	0.61	0.71	0.73	0.76	0.78	0.84	0.87	0.93	0.95	0.96	1.00	1.00	1.00	1.00	1.00	1.00	1.00	1.00	1.00
16 1/2	0.48	0.52	0.55	0.59	0.64	0.74	0.77	0.79	0.82	0.88	0.91	0.97	0.99	1.00	1.00	1.00	1.00	1.00	1.00	1.00	1.00	1.00	1.00
17	0.48	0.52	0.56	0.60	0.65	0.75	0.78	0.80	0.83	0.89	0.92	0.99	1.00	1.00	1.00	1.00	1.00	1.00	1.00	1.00	1.00	1.00	1.00
17 7/8	0.49	0.54	0.57	0.61	0.66	0.77	0.79	0.82	0.85	0.91	0.94	1.00	1.00	1.00	1.00	1.00	1.00	1.00	1.00	1.00	1.00	1.00	1.00
18	0.50	0.54	0.58	0.61	0.66	0.77	0.80	0.82	0.85	0.92	0.95	1.00	1.00	1.00	1.00	1.00	1.00	1.00	1.00	1.00	1.00	1.00	1.00
19	0.51	0.55	0.59	0.63	0.68	0.79	0.82	0.84	0.87	0.94	0.97	1.00	1.00	1.00	1.00	1.00	1.00	1.00	1.00	1.00	1.00	1.00	1.00
19 1/4	0.51	0.55	0.59	0.63	0.68	0.79	0.82	0.85	0.87	0.94	0.97	1.00	1.00	1.00	1.00	1.00	1.00	1.00	1.00	1.00	1.00	1.00	1.00
19 1/2	0.51	0.55	0.59	0.63	0.69	0.80	0.82	0.85	0.88	0.95	0.98	1.00	1.00	1.00	1.00	1.00	1.00	1.00	1.00	1.00	1.00	1.00	1.00
20 5/8	0.52	0.57	0.61	0.65	0.70	0.81	0.84	0.87	0.89	0.97	1.00	1.00	1.00	1.00	1.00	1.00	1.00	1.00	1.00	1.00	1.00	1.00	1.00
21	0.53	0.57	0.61	0.65	0.71	0.82	0.85	0.87	0.90	0.97	1.00	1.00	1.00	1.00	1.00	1.00	1.00	1.00	1.00	1.00	1.00	1.00	1.00
22	0.53	0.58	0.62	0.66	0.72	0.83	0.86	0.89	0.91	0.99	1.00	1.00	1.00	1.00	1.00	1.00	1.00	1.00	1.00	1.00	1.00	1.00	1.00
22 1/2	0.54	0.58	0.63	0.67	0.72	0.84	0.87	0.89	0.92	1.00	1.00	1.00	1.00	1.00	1.00	1.00	1.00	1.00	1.00	1.00	1.00	1.00	1.00
23	0.54	0.59	0.63	0.67	0.73	0.84	0.87	0.90	0.93	1.00	1.00	1.00	1.00	1.00	1.00	1.00	1.00	1.00	1.00	1.00	1.00	1.00	1.00
23 3/8	0.55	0.59	0.63	0.67	0.73	0.85	0.88	0.91	0.93	1.00	1.00	1.00	1.00	1.00	1.00	1.00	1.00	1.00	1.00	1.00	1.00	1.00	1.00
24	0.55	0.60	0.64	0.68	0.74	0.85	0.88	0.91	0.94	1.00	1.00	1.00	1.00	1.00	1.00	1.00	1.00	1.00	1.00	1.00	1.00	1.00	1.00
30	0.58	0.63	0.68	0.72	0.78	0.91	0.94	0.97	1.00	1.00	1.00	1.00	1.00	1.00	1.00	1.00	1.00	1.00	1.00	1.00	1.00	1.00	1.00
36	0.61	0.66	0.70	0.75	0.81	0.94	0.98	1.00	1.00	1.00	1.00	1.00	1.00	1.00	1.00	1.00	1.00	1.00	1.00	1.00	1.00	1.00	1.00
60	0.65	0.71	0.76	0.81	0.88	1.00	1.00	1.00	1.00	1.00	1.00	1.00	1.00	1.00	1.00	1.00	1.00	1.00	1.00	1.00	1.00	1.00	1.00

1. Design load ratios (R_s) assume bending about the X-X axis, and continuous lateral support along the compression edge.
2. Design load ratios (R_s) may be interpolated for depths (d) other than those shown.
3. For the purposes of this table, the dimension d is measured in the direction normal to the axis about which bending occurs. The dimensions d and b are dressed, dry dimensions.
4. The design moment for fire, $F_{b,f}S_f$, is approximated by multiplying the adjusted ASD design moment used in structural design, $F_b'S$, by R_s . ($F_{b,f}S_f = F_b'S R_s$)

Compression Members

Structural: $D+L \leq R_s F_c A_s C_{p-s} C_D C_M C_t$

Fire: $D+L \leq 2.58 F_c A_f C_{p-f}$

Where;

- D = Design dead load
- L = Design live load
- R_s = Design load ratio
- F_c = Tabulated compression parallel-to-grain design value
- C_{p-s} = Column stability factor using full (initial) cross-section dimensions
- C_{p-f} = Column stability factor using cross-section dimensions reduced from fire exposure, with a column buckling strength, F_{cE}, multiplied by a factor of 2.03 per NDS Section 16.2.2.
- A_s = Area of full (initial) cross-section dimensions
- A_f = Area of cross-section reduced from fire exposure
- C_D = Load Duration factor
- C_M = Wet Service factor
- C_t = Temperature factor

Solve for R_s:

$$R_s = \frac{2.58 A_f C_{p-f}}{A_s C_{p-s} C_D C_M C_t}$$

While these relationships can be directly calculated using NDS provisions, they cannot be easily tabulated directly for columns with non-square cross sections. However, to address columns with non-square cross sections of dimensions d x b where d is measured in the direction normal to the axis about which buckling is considered, design load ratios may be tabulated for columns having square cross sections of dimensions d x d, along with a multiplier to adjust for dimension b. The R_s ratio for the column under evaluation is calculated as the product of these two values, which are designated as R_{s1} and R_{s2}, respectively. Thus, for standard reference conditions (where C_D=1.0, C_M=1.0 and C_t=1.0) and four-sided fire exposure, R_{s1} and R_{s2} are calculated as follows:

$$R_{s1} = \frac{2.58 C_{p-f} (d - 2a_{eff})^2}{C_{p-s} (d)^2}$$

$$R_{s2} = \frac{\left(1 - 2 \frac{a_{eff}}{b}\right)}{\left(1 - 2 \frac{a_{eff}}{d}\right)}$$

$$R_s = R_{s1} R_{s2} \leq 1.0$$

Where;

- d = Cross-sectional dimension measured in the direction normal to the axis about which buckling is considered (see Figure A2)
- b = Cross-sectional dimension measured in the direction parallel to the axis about which buckling is considered (see Figure A2)
- a_{eff} = Effective char depth

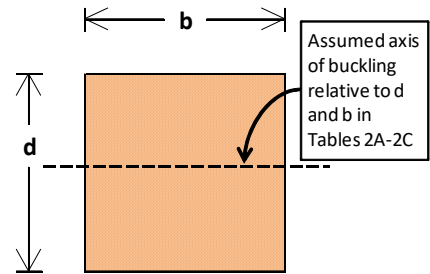

Figure A2

The R_{s1} and R_{s2} values given in Table A2(1-hr), Table A2(1.5-hr) and Table A2(2-hr) were developed for columns under standard reference conditions (C_D=1.0; C_M=1.0; C_t=1.0), assuming four-sided exposure for 1-hour, 1.5-hour and 2-hour ratings, respectively. They may also be conservatively applied to three-sided fire exposures. It should be noted that design load ratios calculated using the tabulated R_{s1} and R_{s2} values will usually yield a slightly conservative value. This is because they are derived based on the most conservative result using c = 0.8 and c = 0.9, which allows them to be used

for sawn lumber, structural glued laminated timber, or structural composite lumber. Additionally, The R_{s1} values are also based on the assumption that $E_{min}'/F_c^* = 350$. Because of this, the design load ratios, R_s , may conservatively be used for all species and grades where the ratio of E_{min}' to F_c^* is greater than or equal to 350.

Table A2(1-hr) Design Load Ratios, $R_s = (R_{s1})(R_{s2}) \leq 1.0$, for Compression Members Exposed on Four Sides
1 – HOUR RATING (Structural Calculations at Standard Reference Conditions: $C_D=1.0, C_M=1.0, C_t=1.0, C_i=1.0$)

L_e/d	Depth of Member, d (measured in the direction normal to the axis about which buckling is considered)																					
	5-1/2	6	6-3/4	6-7/8	7-1/4	7-1/2	8-1/4	8-1/2	8-3/4	9	9-1/4	9-5/8	10-1/2	10-3/4	11	11-1/4	12	15	18	21	24	36
	R_{s1} - Design Stress Adjustment for L_e/d																					
0	0.31	0.41	0.56	0.59	0.65	0.70	0.82	0.86	0.89	0.93	0.96	1.01	1.11	1.14	1.17	1.19	1.26	1.49	1.65	1.77	1.86	2.09
2	0.30	0.40	0.55	0.58	0.65	0.69	0.81	0.85	0.89	0.92	0.96	1.00	1.11	1.14	1.16	1.19	1.26	1.49	1.65	1.77	1.86	2.09
4	0.26	0.37	0.52	0.55	0.62	0.66	0.79	0.83	0.86	0.90	0.93	0.98	1.09	1.11	1.14	1.17	1.24	1.47	1.63	1.75	1.85	2.08
6	0.19	0.29	0.45	0.48	0.55	0.60	0.73	0.77	0.81	0.85	0.88	0.93	1.04	1.07	1.10	1.12	1.20	1.43	1.60	1.72	1.82	2.05
8	0.12	0.21	0.35	0.38	0.45	0.50	0.63	0.67	0.71	0.75	0.79	0.84	0.96	0.99	1.01	1.04	1.12	1.37	1.54	1.67	1.77	2.01
10	0.084	0.15	0.26	0.28	0.35	0.39	0.51	0.55	0.59	0.63	0.66	0.72	0.83	0.86	0.89	0.92	1.00	1.26	1.45	1.58	1.69	1.95
12	0.061	0.11	0.20	0.22	0.27	0.30	0.41	0.44	0.48	0.51	0.55	0.59	0.70	0.73	0.76	0.79	0.87	1.13	1.32	1.46	1.58	1.85
14	0.048	0.086	0.16	0.17	0.21	0.24	0.33	0.36	0.39	0.42	0.45	0.49	0.59	0.61	0.64	0.67	0.74	1.00	1.19	1.33	1.45	1.73
16	0.040	0.072	0.13	0.14	0.18	0.20	0.28	0.30	0.33	0.35	0.38	0.42	0.50	0.53	0.55	0.57	0.64	0.87	1.06	1.20	1.32	1.61
18	0.036	0.064	0.12	0.13	0.16	0.18	0.25	0.27	0.29	0.32	0.34	0.38	0.45	0.48	0.50	0.52	0.58	0.80	0.97	1.11	1.22	1.50
20	0.033	0.060	0.11	0.12	0.15	0.17	0.23	0.25	0.28	0.30	0.32	0.35	0.43	0.45	0.47	0.49	0.55	0.75	0.92	1.05	1.16	1.44
22	0.032	0.057	0.11	0.12	0.14	0.16	0.22	0.25	0.27	0.29	0.31	0.34	0.41	0.43	0.45	0.47	0.53	0.73	0.89	1.02	1.13	1.41
24	0.031	0.056	0.10	0.11	0.14	0.16	0.22	0.24	0.26	0.28	0.30	0.33	0.40	0.42	0.44	0.46	0.52	0.71	0.87	1.00	1.11	1.38
26	0.031	0.055	0.10	0.11	0.14	0.16	0.22	0.24	0.26	0.28	0.30	0.33	0.40	0.42	0.44	0.45	0.51	0.71	0.86	0.99	1.10	1.37
28	0.030	0.054	0.10	0.11	0.14	0.16	0.21	0.23	0.25	0.27	0.29	0.32	0.39	0.41	0.43	0.45	0.51	0.70	0.86	0.98	1.09	1.36
30	0.030	0.054	0.10	0.11	0.14	0.15	0.21	0.23	0.25	0.27	0.29	0.32	0.39	0.41	0.43	0.45	0.50	0.70	0.85	0.98	1.08	1.36
40	0.029	0.053	0.098	0.11	0.13	0.15	0.21	0.23	0.25	0.27	0.29	0.32	0.38	0.40	0.42	0.44	0.49	0.69	0.84	0.97	1.07	1.34
50	0.029	0.053	0.097	0.11	0.13	0.15	0.21	0.23	0.25	0.27	0.29	0.31	0.38	0.40	0.42	0.44	0.49	0.68	0.84	0.96	1.07	1.34
b	R_{s2} - Design Stress Adjustment for Width, b, of Column																					
5-1/2	1.00	0.86	0.74	0.73	0.69	0.66	0.61	0.60	0.59	0.58	0.57	0.55	0.53	0.52	0.51	0.51	0.49	0.45	0.43	0.42	0.41	0.38
6	1.16	1.00	0.86	0.84	0.79	0.77	0.71	0.69	0.68	0.67	0.65	0.64	0.61	0.60	0.59	0.59	0.57	0.53	0.50	0.48	0.47	0.44
6-3/4	1.35	1.17	1.00	0.98	0.93	0.90	0.83	0.81	0.79	0.78	0.76	0.75	0.71	0.70	0.69	0.69	0.67	0.61	0.58	0.56	0.55	0.52
6-7/8	1.38	1.19	1.02	1.00	0.95	0.92	0.85	0.83	0.81	0.79	0.78	0.76	0.72	0.71	0.70	0.68	0.63	0.60	0.57	0.56	0.53	0.53
7-1/4	1.46	1.26	1.08	1.06	1.00	0.97	0.89	0.87	0.86	0.84	0.82	0.80	0.77	0.76	0.75	0.74	0.72	0.66	0.63	0.61	0.59	0.56
7-1/2	1.51	1.30	1.11	1.09	1.03	1.00	0.92	0.90	0.88	0.87	0.85	0.83	0.79	0.78	0.77	0.76	0.74	0.68	0.65	0.63	0.61	0.58
8-1/4	1.63	1.41	1.21	1.18	1.12	1.08	1.00	0.98	0.96	0.94	0.92	0.90	0.86	0.85	0.84	0.83	0.81	0.74	0.70	0.68	0.66	0.63
8-1/2	1.67	1.44	1.24	1.21	1.15	1.11	1.02	1.00	0.98	0.96	0.94	0.92	0.88	0.87	0.86	0.85	0.82	0.76	0.72	0.70	0.68	0.64
8-3/4	1.70	1.47	1.26	1.24	1.17	1.13	1.04	1.02	1.00	0.98	0.96	0.94	0.90	0.88	0.87	0.87	0.84	0.77	0.74	0.71	0.69	0.65
9	1.74	1.50	1.29	1.26	1.19	1.15	1.06	1.04	1.02	1.00	0.98	0.96	0.91	0.90	0.89	0.88	0.86	0.79	0.75	0.72	0.71	0.67
9-1/4	1.77	1.53	1.31	1.28	1.21	1.17	1.08	1.06	1.04	1.02	1.00	0.98	0.93	0.92	0.91	0.90	0.87	0.80	0.76	0.74	0.72	0.68
9-5/8	1.81	1.56	1.34	1.31	1.24	1.20	1.11	1.09	1.06	1.04	1.02	1.00	0.95	0.94	0.93	0.92	0.89	0.82	0.78	0.76	0.74	0.70
10-1/2	1.90	1.64	1.41	1.38	1.31	1.26	1.17	1.14	1.12	1.10	1.08	1.05	1.00	0.99	0.98	0.97	0.94	0.86	0.82	0.79	0.77	0.73
10-3/4	1.93	1.66	1.43	1.40	1.32	1.28	1.18	1.15	1.13	1.11	1.09	1.06	1.01	1.00	0.99	0.98	0.95	0.88	0.83	0.80	0.78	0.74
11	1.95	1.68	1.44	1.41	1.34	1.29	1.19	1.17	1.14	1.12	1.10	1.07	1.02	1.01	1.00	0.99	0.96	0.89	0.84	0.81	0.79	0.75
11-1/4	1.97	1.70	1.46	1.43	1.35	1.31	1.21	1.18	1.16	1.13	1.11	1.09	1.03	1.02	1.01	1.00	0.97	0.89	0.85	0.82	0.80	0.76
12	2.03	1.75	1.50	1.47	1.39	1.35	1.24	1.21	1.19	1.17	1.15	1.12	1.07	1.05	1.04	1.03	1.00	0.92	0.88	0.84	0.82	0.78
15	2.20	1.90	1.63	1.60	1.51	1.46	1.35	1.32	1.29	1.27	1.24	1.21	1.16	1.14	1.13	1.12	1.09	1.00	0.95	0.92	0.89	0.84
18	2.32	2.00	1.71	1.68	1.59	1.54	1.42	1.39	1.36	1.33	1.31	1.28	1.22	1.20	1.19	1.18	1.14	1.05	1.00	0.97	0.94	0.89
21	2.40	2.07	1.78	1.74	1.65	1.59	1.47	1.44	1.41	1.38	1.36	1.32	1.26	1.25	1.23	1.22	1.18	1.09	1.04	1.00	0.97	0.92
24	2.46	2.13	1.82	1.78	1.69	1.63	1.51	1.47	1.44	1.42	1.39	1.36	1.29	1.28	1.26	1.25	1.21	1.12	1.06	1.03	1.00	0.94
36	2.61	2.25	1.93	1.89	1.79	1.73	1.60	1.56	1.53	1.50	1.47	1.44	1.37	1.35	1.34	1.32	1.29	1.18	1.13	1.09	1.06	1.00

- Design load ratios are calculated as the product of R_{s1} and R_{s2} , but should not be taken as greater than 1.0. ($R_s = [R_{s1}][R_{s2}] \leq 1.0$)
- For the purposes of this table, the dimension d is measured in the direction normal to the axis about which buckling is considered. The designer should consider buckling about both axes and use the lesser design value. The dimensions d and b are dressed, dry dimensions.
- Tabulated values may be used for sawn lumber, structural glued laminated timber, or structural composite lumber where $E_{min}/F_c \geq 350$.
- Values of R_{s1} and R_{s2} may be interpolated for values of d, L_e/d , and b other than those shown.

Table A2(1.5-hr) Design Load Ratios, $R_s = (R_{s1})(R_{s2}) \leq 1.0$, for Compression Members Exposed on Four Sides
1.5 – HOUR RATING (Structural Calculations at Standard Reference Conditions: $C_D=1.0$, $C_M=1.0$, $C_i=1.0$, $C_i=1.0$)

L_e/d	Depth of Member, d (measured in the direction normal to the axis about which buckling is considered)																					
	6-3/4	6-7/8	7-1/4	7-1/2	8-1/4	8-1/2	8-3/4	9	9-1/4	9-5/8	10-1/2	10-3/4	11	11-1/4	12	12-1/4	15	16-1/2	18	21	24	36
	R_{s1} - Design Stress Adjustment for L_e/d																					
0	0.17	0.19	0.25	0.29	0.40	0.44	0.47	0.51	0.54	0.59	0.71	0.74	0.77	0.79	0.88	0.90	1.15	1.25	1.34	1.50	1.62	1.91
2	0.16	0.18	0.24	0.28	0.39	0.43	0.46	0.50	0.54	0.59	0.70	0.73	0.76	0.79	0.87	0.90	1.14	1.25	1.34	1.49	1.61	1.91
4	0.12	0.14	0.20	0.24	0.36	0.39	0.43	0.47	0.50	0.56	0.67	0.70	0.73	0.76	0.84	0.87	1.12	1.23	1.32	1.47	1.60	1.90
6	0.066	0.080	0.13	0.16	0.28	0.32	0.36	0.40	0.43	0.49	0.61	0.64	0.67	0.70	0.79	0.82	1.07	1.18	1.28	1.44	1.56	1.87
8	0.041	0.049	0.081	0.11	0.20	0.23	0.26	0.30	0.33	0.39	0.51	0.54	0.57	0.60	0.69	0.72	0.99	1.11	1.21	1.37	1.50	1.82
10	0.027	0.033	0.055	0.073	0.14	0.16	0.19	0.22	0.25	0.29	0.40	0.43	0.45	0.48	0.57	0.60	0.87	0.99	1.09	1.27	1.41	1.75
12	0.019	0.024	0.040	0.053	0.10	0.12	0.14	0.16	0.19	0.22	0.31	0.33	0.36	0.39	0.46	0.49	0.74	0.85	0.96	1.14	1.28	1.63
14	0.015	0.018	0.031	0.041	0.080	0.095	0.11	0.13	0.15	0.18	0.25	0.27	0.29	0.31	0.37	0.39	0.62	0.73	0.83	1.01	1.15	1.51
16	0.013	0.015	0.026	0.034	0.067	0.080	0.094	0.11	0.12	0.15	0.21	0.22	0.24	0.26	0.32	0.33	0.53	0.63	0.72	0.88	1.01	1.38
18	0.011	0.014	0.023	0.031	0.060	0.071	0.084	0.097	0.11	0.13	0.19	0.20	0.22	0.23	0.28	0.30	0.48	0.57	0.65	0.80	0.93	1.28
20	0.010	0.013	0.022	0.029	0.056	0.067	0.078	0.090	0.10	0.12	0.17	0.19	0.20	0.22	0.27	0.28	0.45	0.54	0.62	0.76	0.88	1.22
22	0.010	0.012	0.021	0.028	0.054	0.064	0.075	0.087	0.099	0.12	0.17	0.18	0.20	0.21	0.26	0.27	0.43	0.52	0.60	0.74	0.85	1.18
24	0.010	0.012	0.020	0.027	0.052	0.062	0.073	0.085	0.097	0.12	0.16	0.18	0.19	0.21	0.25	0.27	0.43	0.51	0.58	0.72	0.84	1.17
26	0.010	0.012	0.020	0.026	0.051	0.061	0.072	0.083	0.095	0.11	0.16	0.17	0.19	0.20	0.25	0.26	0.42	0.50	0.58	0.71	0.83	1.15
28	0.010	0.012	0.020	0.026	0.051	0.061	0.071	0.082	0.094	0.11	0.16	0.17	0.19	0.20	0.24	0.26	0.42	0.50	0.57	0.71	0.82	1.14
30		0.012	0.019	0.026	0.050	0.060	0.071	0.082	0.093	0.11	0.16	0.17	0.19	0.20	0.24	0.26	0.41	0.49	0.57	0.70	0.82	1.14
40		0.011	0.019	0.025	0.049	0.059	0.069	0.080	0.092	0.11	0.15	0.17	0.18	0.20	0.24	0.25	0.41	0.48	0.56	0.69	0.81	1.13
50		0.011	0.019	0.025	0.049	0.059	0.069	0.080	0.091	0.11	0.15	0.17	0.18	0.19	0.24	0.25	0.40	0.48	0.56	0.69	0.80	1.12
	R_{s2} - Design Stress Adjustment for Width, b, of Column																					
6-3/4	1.00	0.95	0.83	0.78	0.66	0.63	0.60	0.58	0.56	0.54	0.49	0.48	0.47	0.47	0.44	0.44	0.39	0.37	0.36	0.34	0.33	0.10
6-7/8	1.05	1.00	0.88	0.82	0.69	0.66	0.64	0.61	0.59	0.57	0.52	0.51	0.50	0.49	0.47	0.46	0.41	0.39	0.38	0.36	0.34	0.19
7-1/4	1.20	1.14	1.00	0.93	0.79	0.75	0.72	0.70	0.67	0.64	0.59	0.58	0.57	0.56	0.53	0.52	0.46	0.44	0.43	0.41	0.39	0.30
7-1/2	1.29	1.22	1.07	1.00	0.85	0.81	0.78	0.75	0.72	0.69	0.64	0.62	0.61	0.60	0.57	0.56	0.50	0.48	0.46	0.44	0.42	0.32
8-1/4	1.52	1.45	1.27	1.18	1.00	0.96	0.92	0.89	0.86	0.82	0.75	0.74	0.72	0.71	0.67	0.66	0.59	0.56	0.54	0.52	0.50	0.36
8-1/2	1.59	1.51	1.33	1.24	1.05	1.00	0.96	0.93	0.90	0.86	0.79	0.77	0.75	0.74	0.71	0.70	0.62	0.59	0.57	0.54	0.52	0.39
8-3/4	1.66	1.57	1.38	1.29	1.09	1.04	1.00	0.96	0.93	0.89	0.82	0.80	0.79	0.77	0.73	0.72	0.64	0.61	0.59	0.56	0.54	0.46
9	1.72	1.63	1.43	1.33	1.13	1.08	1.04	1.00	0.97	0.92	0.85	0.83	0.81	0.80	0.76	0.75	0.67	0.64	0.61	0.58	0.56	0.48
9-1/4	1.78	1.69	1.48	1.38	1.17	1.12	1.07	1.03	1.00	0.96	0.88	0.86	0.84	0.83	0.79	0.78	0.69	0.66	0.64	0.60	0.58	0.50
9-5/8	1.86	1.77	1.55	1.44	1.22	1.17	1.12	1.08	1.05	1.00	0.92	0.90	0.88	0.86	0.82	0.81	0.72	0.69	0.66	0.63	0.61	0.52
10-1/2	2.03	1.92	1.69	1.57	1.33	1.27	1.22	1.18	1.14	1.09	1.00	0.98	0.96	0.94	0.90	0.88	0.79	0.75	0.72	0.69	0.66	0.53
10-3/4	2.07	1.97	1.73	1.61	1.36	1.30	1.25	1.20	1.16	1.11	1.02	1.00	0.98	0.96	0.92	0.90	0.80	0.77	0.74	0.70	0.68	0.56
11	2.11	2.00	1.76	1.64	1.39	1.33	1.27	1.23	1.19	1.14	1.04	1.02	1.00	0.98	0.93	0.92	0.82	0.78	0.75	0.72	0.69	0.61
11-1/4	2.15	2.04	1.79	1.67	1.41	1.35	1.30	1.25	1.21	1.16	1.06	1.04	1.02	1.00	0.95	0.94	0.83	0.80	0.77	0.73	0.70	0.62
12	2.26	2.14	1.88	1.75	1.48	1.42	1.36	1.31	1.27	1.21	1.11	1.09	1.07	1.05	1.00	0.99	0.87	0.84	0.81	0.77	0.74	0.63
12-1/4	2.29	2.18	1.91	1.78	1.50	1.44	1.38	1.33	1.29	1.23	1.13	1.11	1.09	1.07	1.01	1.00	0.89	0.85	0.82	0.78	0.75	0.64
15	2.58	2.45	2.15	2.00	1.69	1.62	1.56	1.50	1.45	1.39	1.27	1.25	1.22	1.20	1.14	1.13	1.00	0.96	0.92	0.87	0.84	0.68
16-1/2	2.70	2.56	2.25	2.09	1.77	1.69	1.63	1.57	1.52	1.45	1.33	1.30	1.28	1.26	1.20	1.18	1.05	1.00	0.96	0.91	0.88	0.77
18	2.79	2.66	2.33	2.17	1.84	1.76	1.69	1.63	1.57	1.50	1.38	1.35	1.32	1.30	1.24	1.22	1.08	1.04	1.00	0.95	0.91	0.84
21	2.95	2.80	2.46	2.29	1.94	1.85	1.78	1.72	1.66	1.59	1.46	1.43	1.40	1.37	1.31	1.29	1.14	1.09	1.06	1.00	0.96	0.88
24	3.06	2.91	2.56	2.38	2.01	1.93	1.85	1.78	1.72	1.65	1.51	1.48	1.45	1.43	1.36	1.34	1.19	1.14	1.10	1.04	1.00	0.92
36	3.33	3.17	2.78	2.59	2.19	2.09	2.01	1.94	1.88	1.79	1.65	1.61	1.58	1.55	1.48	1.46	1.29	1.24	1.19	1.13	1.09	1.00

1. Design load ratios are calculated as the product of R_{s1} and R_{s2} , but should not be taken as greater than 1.0. ($R_s = [R_{s1}][R_{s2}] \leq 1.0$)
2. For the purposes of this table, the dimension d is measured in the direction normal to the axis about which buckling is considered. The designer should consider buckling about both axes and use the lesser design value. The dimensions d and b are dressed, dry dimensions.
3. Tabulated values may be used for sawn lumber, structural glued laminated timber, or structural composite lumber where $E_{min}/F_c^* \geq 350$.
4. Values of R_{s1} and R_{s2} may be interpolated for values of d, L_e/d , and b other than those shown.

Table A2(2-hr) Design Load Ratios, $R_s = (R_{s1})(R_{s2}) \leq 1.0$, for Compression Members Exposed on Four Sides
2 – HOUR RATING (Structural Calculations at Standard Reference Conditions: $C_D=1.0, C_M=1.0, C_t=1.0, C_i=1.0$)

L_e/d	Depth of Member, d (measured in the direction normal to the axis about which buckling is considered)																					
	8-1/4	8-1/2	8-3/4	9	9-1/4	9-5/8	10-1/2	10-3/4	11	11-1/4	12	12-1/4	13-1/4	13-1/2	13-3/4	15	16-1/2	17	18	21	24	36
	R_{s1} - Design Stress Adjustment for L_e/d																					
0	0.14	0.17	0.20	0.23	0.26	0.30	0.41	0.44	0.47	0.49	0.58	0.60	0.70	0.73	0.75	0.86	0.98	1.02	1.09	1.26	1.40	1.75
2	0.13	0.16	0.19	0.22	0.25	0.29	0.40	0.43	0.46	0.49	0.57	0.60	0.70	0.72	0.75	0.86	0.97	1.01	1.08	1.25	1.39	1.75
4	0.085	0.11	0.14	0.18	0.21	0.26	0.37	0.40	0.43	0.45	0.54	0.57	0.67	0.69	0.72	0.83	0.95	0.99	1.06	1.23	1.38	1.73
6	0.045	0.064	0.086	0.11	0.14	0.18	0.29	0.32	0.35	0.38	0.47	0.50	0.61	0.63	0.66	0.78	0.90	0.94	1.01	1.19	1.34	1.70
8	0.027	0.039	0.053	0.070	0.088	0.12	0.20	0.23	0.26	0.28	0.37	0.40	0.50	0.53	0.56	0.68	0.81	0.85	0.92	1.12	1.27	1.65
10	0.018	0.026	0.036	0.047	0.060	0.082	0.15	0.17	0.19	0.21	0.28	0.30	0.39	0.42	0.44	0.56	0.68	0.72	0.80	1.00	1.16	1.56
12	0.013	0.019	0.026	0.034	0.043	0.060	0.11	0.12	0.14	0.16	0.21	0.23	0.31	0.33	0.35	0.45	0.56	0.60	0.67	0.86	1.02	1.44
14	0.010	0.015	0.020	0.026	0.034	0.047	0.084	0.096	0.11	0.12	0.17	0.18	0.24	0.26	0.28	0.36	0.46	0.50	0.56	0.74	0.89	1.31
16		0.012	0.017	0.022	0.028	0.039	0.070	0.080	0.091	0.10	0.14	0.15	0.21	0.22	0.23	0.31	0.39	0.42	0.48	0.64	0.78	1.18
18		0.011	0.015	0.020	0.025	0.035	0.063	0.072	0.082	0.092	0.12	0.14	0.18	0.20	0.21	0.28	0.35	0.38	0.43	0.58	0.71	1.08
20		0.010	0.014	0.018	0.023	0.032	0.058	0.067	0.076	0.086	0.12	0.13	0.17	0.18	0.20	0.26	0.33	0.36	0.41	0.54	0.67	1.03
22		0.010	0.013	0.018	0.023	0.031	0.056	0.064	0.073	0.082	0.11	0.12	0.17	0.18	0.19	0.25	0.32	0.34	0.39	0.52	0.64	1.00
24			0.013	0.017	0.022	0.030	0.055	0.063	0.071	0.080	0.11	0.12	0.16	0.17	0.19	0.24	0.31	0.34	0.38	0.51	0.63	0.98
26			0.013	0.017	0.022	0.030	0.054	0.062	0.070	0.079	0.11	0.12	0.16	0.17	0.18	0.24	0.31	0.33	0.38	0.51	0.62	0.97
28			0.013	0.017	0.021	0.029	0.053	0.061	0.069	0.078	0.11	0.12	0.16	0.17	0.18	0.24	0.31	0.33	0.37	0.50	0.62	0.96
30			0.013	0.017	0.021	0.029	0.053	0.061	0.069	0.078	0.11	0.12	0.16	0.17	0.18	0.24	0.30	0.33	0.37	0.50	0.61	0.96
40			0.012	0.016	0.021	0.029	0.052	0.059	0.068	0.076	0.10	0.11	0.15	0.16	0.18	0.23	0.30	0.32	0.36	0.49	0.61	0.95
50			0.012	0.016	0.021	0.028	0.051	0.059	0.067	0.075	0.10	0.11	0.15	0.16	0.17	0.23	0.30	0.32	0.36	0.49	0.60	0.94
	R_{s2} - Design Stress Adjustment for Width, b, of Column																					
8-1/4	1.00	0.91	0.84	0.79	0.74	0.68	0.59	0.57	0.55	0.53	0.49	0.48	0.45	0.44	0.43	0.40	0.38	0.37	0.36	0.33	0.32	0.28
8-1/2	1.10	1.00	0.92	0.86	0.81	0.75	0.64	0.62	0.60	0.58	0.54	0.53	0.49	0.48	0.47	0.44	0.42	0.41	0.39	0.37	0.35	0.31
8-3/4	1.19	1.08	1.00	0.93	0.88	0.81	0.70	0.67	0.65	0.63	0.59	0.57	0.53	0.52	0.51	0.48	0.45	0.44	0.43	0.40	0.38	0.34
9	1.27	1.16	1.07	1.00	0.94	0.87	0.75	0.72	0.70	0.68	0.63	0.61	0.57	0.56	0.55	0.51	0.48	0.47	0.46	0.43	0.40	0.36
9-1/4	1.35	1.24	1.14	1.06	1.00	0.92	0.80	0.77	0.74	0.72	0.67	0.65	0.61	0.60	0.59	0.55	0.51	0.50	0.49	0.45	0.43	0.38
9-5/8	1.47	1.34	1.24	1.15	1.08	1.00	0.86	0.83	0.81	0.78	0.73	0.71	0.66	0.65	0.64	0.59	0.56	0.55	0.53	0.49	0.47	0.42
10-1/2	1.70	1.55	1.43	1.34	1.26	1.16	1.00	0.97	0.94	0.91	0.84	0.82	0.76	0.75	0.74	0.69	0.64	0.63	0.61	0.57	0.54	0.48
10-3/4	1.76	1.61	1.48	1.38	1.30	1.20	1.04	1.00	0.97	0.94	0.87	0.85	0.79	0.77	0.76	0.71	0.67	0.66	0.63	0.59	0.56	0.50
11	1.82	1.66	1.53	1.43	1.34	1.24	1.07	1.03	1.00	0.97	0.90	0.88	0.81	0.80	0.79	0.73	0.69	0.68	0.66	0.61	0.58	0.52
11-1/4	1.88	1.71	1.58	1.47	1.38	1.28	1.10	1.06	1.03	1.00	0.93	0.91	0.84	0.82	0.81	0.76	0.71	0.70	0.68	0.63	0.59	0.53
12	2.03	1.85	1.71	1.59	1.50	1.38	1.19	1.15	1.11	1.08	1.00	0.98	0.90	0.89	0.88	0.82	0.77	0.75	0.73	0.68	0.64	0.57
12-1/4	2.07	1.89	1.74	1.63	1.53	1.41	1.22	1.17	1.14	1.10	1.02	1.00	0.93	0.91	0.90	0.84	0.78	0.77	0.75	0.69	0.66	0.59
13-1/4	2.24	2.04	1.89	1.76	1.65	1.52	1.31	1.27	1.23	1.19	1.11	1.08	1.00	0.98	0.97	0.90	0.85	0.83	0.81	0.75	0.71	0.63
13-1/2	2.28	2.08	1.92	1.79	1.68	1.55	1.34	1.29	1.25	1.21	1.12	1.10	1.02	1.00	0.98	0.92	0.86	0.85	0.82	0.76	0.72	0.64
13-3/4	2.31	2.11	1.95	1.82	1.71	1.57	1.36	1.31	1.27	1.23	1.14	1.12	1.03	1.02	1.00	0.93	0.88	0.86	0.83	0.77	0.73	0.66
15	2.48	2.26	2.09	1.95	1.83	1.69	1.45	1.40	1.36	1.32	1.22	1.20	1.11	1.09	1.07	1.00	0.94	0.92	0.89	0.83	0.79	0.70
16-1/2	2.64	2.41	2.22	2.07	1.95	1.80	1.55	1.50	1.45	1.41	1.30	1.27	1.18	1.16	1.14	1.07	1.00	0.98	0.95	0.88	0.84	0.75
17	2.69	2.45	2.27	2.11	1.99	1.83	1.58	1.53	1.48	1.43	1.33	1.30	1.20	1.18	1.16	1.09	1.02	1.00	0.97	0.90	0.85	0.76
18	2.78	2.53	2.34	2.18	2.05	1.89	1.63	1.58	1.53	1.48	1.37	1.34	1.24	1.22	1.20	1.12	1.05	1.03	1.00	0.93	0.88	0.79
21	2.99	2.73	2.52	2.35	2.21	2.04	1.76	1.70	1.64	1.60	1.48	1.44	1.34	1.31	1.29	1.21	1.13	1.11	1.08	1.00	0.95	0.85
24	3.15	2.88	2.66	2.48	2.33	2.15	1.85	1.79	1.73	1.68	1.56	1.52	1.41	1.39	1.36	1.27	1.19	1.17	1.14	1.05	1.00	0.89
36	3.53	3.22	2.97	2.77	2.61	2.40	2.07	2.00	1.94	1.88	1.74	1.70	1.58	1.55	1.53	1.43	1.34	1.31	1.27	1.18	1.12	1.00

1. Design load ratios are calculated as the product of R_{s1} and R_{s2} , but should not be taken as greater than 1.0. ($R_s = [R_{s1}][R_{s2}] \leq 1.0$)
2. For the purposes of this table, the dimension d is measured in the direction normal to the axis about which buckling is considered. The designer should consider buckling about both axes and use the lesser design value. The dimensions d and b are dry dressed dimensions.
3. Tabulated values may be used for sawn lumber, structural glued laminated timber, or structural composite lumber where $E_{min}/F_c^* \geq 350$.
4. Values of R_{s1} and R_{s2} may be interpolated for values of d, L_e/d , and b other than those shown.

Timber Decks

Structural: $D+L \leq R_s F_b S_s C_D C_M C_t$

Fire: $D+L \leq 2.85 F_b S_f$

Where;

- D = Design dead load
- L = Design live load
- R_s = Design load ratio
- F_b = Tabulated bending design value
- S_s = Section modulus using full (initial) cross-section dimensions
- S_f = Section modulus using cross-section dimensions reduced from fire exposure
- C_D = Load Duration factor
- C_M = Wet Service factor
- C_t = Temperature factor

Solve for R_s :

$$R_s = \frac{2.85 S_f}{S_s C_D C_M C_t}$$

For butt-jointed timber decks, NDS Section 16.2.5 states that the char rate on the butt-jointed sides of the timber decking shall be taken as 33% (one-third) of the effective char rate. Thus, the charred section modulus is calculated as $S_f = (b-2a/3)(d-a)^2/6$, and the design load ratio, R_s , for butt-jointed timber decking is calculated as follows:

$$R_s = \frac{2.85 \left(b - 2 \frac{a_{eff}}{3} \right) (d - a_{eff})^2}{b d^2 C_D C_M C_t}$$

NDS Section 16.2.5 states that tongue-and-groove timber decks shall be designed as an assembly of wood beams fully exposed on the bottom face only. Thus, the charred section modulus is calculated as $S_f = b(d-a)^2/6$, and the design load ratio, R_s , for tongue-and-groove timber decking is calculated as follows:

$$R_s = \frac{2.85 (d - a_{eff})^2}{d^2 C_D C_M C_t}$$

The design load ratios, R_s , given in Tables A3.1 and A3.2 were developed for butt-jointed and finger-jointed timber decks, respectively, under standard reference conditions ($C_D=1.0$; $C_M=1.0$; $C_t=1.0$).

Table A3.1 Design Load Ratios, R_s , for Butt-Jointed Timber Decks

(Protected on Top Face; Partially Protected on Sides per NDS Section 16.2.5)
 (Structural Calculations at Standard Reference Conditions: $C_D=1.0$, $C_M=1.0$, $C_t=1.0$, $C_i=1.0$,

Width, b	1-HOUR				1.5-HOUR			2-HOUR	
	1-1/2	2-1/2	3-1/2	5-1/2	2-1/2	3-1/2	5-1/2	3-1/2	5-1/2
Depth, d	Design Load Ratio, R_s								
2-1/2	0.05	0.12	0.15	0.18	-	-	-	-	-
3	0.10	0.24	0.30	0.36	0.03	0.04	0.05	-	-
3-1/2	0.14	0.35	0.44	0.53	0.08	0.12	0.16	-	-
4	0.18	0.45	0.57	0.68	0.14	0.21	0.28	0.05	0.08
4-1/2	0.21	0.54	0.68	0.80	0.19	0.30	0.39	0.10	0.16
5	0.24	0.61	0.77	0.92	0.24	0.38	0.50	0.16	0.24
5-1/2	0.27	0.68	0.85	1.00	0.29	0.45	0.59	0.21	0.32

Table A3.2 Design Load Ratios, R_s , for Tongue & Groove Timber Decks

(Protected on Top Face and Sides per NDS Section 16.2.5)

(Structural Calculations at Standard Reference Conditions: $C_D=1.0$, $C_M=1.0$, $C_t=1.0$, $C_i=1.0$,

	1-HOUR	1.5-HOUR	2-HOUR
Depth, d	Design Load Ratio, R_s		
2-1/2	0.22	-	-
3	0.46	0.08	-
3-1/2	0.67	0.23	0.03
4	0.86	0.40	0.12
4-1/2	1.00	0.56	0.25
5	1.00	0.71	0.38
5-1/2	1.00	0.85	0.51

APPENDIX B: Fire Resistance Calculation for Sawn Wood Joists

Starting with a standard char rate for wood equal to 1.5 in./hr, calculate the depth of the char layer depth, a_{char} , and the effective char layer depth, a_{eff} , for structural calculations:

$$\beta_t = \beta_n \frac{(1 \text{ hr})}{(1 \text{ hr})^{0.813}} = 1.5 \text{ in/hr}^{0.813} \quad \text{Eqn. B-1}$$

$$a_{char} = \beta_t t^{0.813} = 1.5t^{0.813} \quad \text{Eqn. B-2}$$

$$a_{eff} = 1.2 a_{char} \quad \text{Eqn. B-3}$$

Where:

β_t = non-linear char rate constant (in/hr^{0.813})

β_n = nominal char rate constant (in/hr) linear char rate based on 1-hour E119 exposure

t = exposure time (hr.)

a_{char} = char depth (in.)

a_{eff} = effective char depth (in.) for structural calculations

For a fully-braced bending member used in a floor or ceiling assembly, the relationship between the allowable bending stress for structural design and the bending member strength for fire design can be estimated using $K=2.85$:

$$R_s = \frac{2.85S_f}{S_s} \quad \text{Eqn. B-3}$$

Expanding Eqn. B-3 in terms of bending section properties:

$$R_s = \frac{2.85(b-2a_{eff})(d-a_{eff})^2/6}{bd^2/6} = 2.85 \left(\frac{b-2a_{eff}}{b} \right) \left(\frac{d-2a_{eff}}{d} \right)^2 \quad \text{Eqn. B-4}$$

Rearranging Eqn. B-4 to solve for a :

$$a_{eff}^3 - a_{eff}^2 \frac{(b+4d)}{2} + a_{eff}(bd + d^2) - \frac{bd^2}{2} \left(1 - \frac{R_s}{2.85} \right) = 0 \quad \text{Eqn. B-5}$$

Where:

R_s = design stress ratio for structural design (0-100% of full design load)

S_f = bending section modulus of remaining cross-section after reducing for char on all exposed surfaces.

S_s = bending section modulus of initial cross-section.

b = breadth of rectangular bending member, in.

d = depth of rectangular bending member, in.

Calculating a direct solution for the effective char depth, a_{eff} , as a function of time and load ratio is complicated, but it can be solved relatively quickly by iteratively solving for the maximum char depth, then back-calculating the fire resistance time by substituting the char depth, a_{char} , back into Eqn. B-2. The following cases for standard lumber dimensions have been determined:

Load Ratio R_s	2x6	2x8	2x10	2x12
	Structural Fire Resistance Time (minutes)			
0.00	20.4	20.4	20.4	20.4
0.10	19.3	19.4	19.4	19.4
0.20	18.2	18.3	18.4	18.5
0.30	17.1	17.3	17.4	17.5
0.40	16.1	16.3	16.5	16.6
0.50	15.1	15.3	15.5	15.6
0.60	14.1	14.4	14.6	14.7
0.70	13.2	13.5	13.7	13.8
0.80	12.3	12.6	12.8	13.0
0.90	11.4	11.8	12.0	12.1
1.00	10.6	10.9	11.2	11.3

APPENDIX C:

Harmathy's Ten Rules of Fire Endurance (Resistance) Rating¹

Rule 1. *The "thermal" fire endurance of a construction consisting of a number of parallel layers is greater than the sum of the "thermal" fire endurance characteristics of the individual layers when exposed separately to fire.*

Where two layers of panel materials, such as gypsum wallboard or plywood, are fastened to studs or joists separately, their combined effect is greater than the sum of their individual contributions to the fire endurance rating of the assembly.

Rule 2. *The fire endurance of a construction does not decrease with the addition of further layers.*

This is a corollary to Rule 1. The fire resistance will not decrease with the addition of layers such as wallboard or other panel materials, regardless of how many layers are added or where they are located within the assembly.

Rule 3. *The fire endurance of constructions containing continuous air gaps or cavities is greater than the fire endurance of similar constructions of the same weight, but containing no air gaps or cavities.*

Wall and ceiling cavities formed by studs and joists protected and encased by wall coverings adds to the fire resistance rating of these assemblies.

Rule 4. *The farther an air gap or cavity is located from the exposed surface, the more beneficial its effect on the fire endurance.*

In cases where cavities are formed by joists or studs and protected by 2-inch-thick panel materials against fire exposure, the beneficial effect of such air cavities is greater than if the protection is only 1/2 inch thick.

Rule 5. *The fire endurance of an assembly cannot be increased by increasing the thickness of a completely enclosed air layer.*

An increase in the gap distance between separated layers does not change the fire resistance of an assembly.

Rule 6. *Layers of materials of low thermal conductivity are better utilized on the side of the construction on which fire is more likely to happen.*

A building material having relatively low thermal conductivity, such as a wood-based material, is more beneficial to the fire resistance of the assembly if placed on the fire-exposed side of the framing than it would be on the opposite side.

Rule 7. *The fire endurance of asymmetrical constructions depends on the direction of heat flow.*

Walls which do not have the same panel materials on both faces will demonstrate different fire resistance ratings depending upon which side is exposed to fire. This rule results as a consequence of Rules 4 and 6, which point out the importance of location of air gaps or cavities and of the sequence of different layers of solids.

Rule 8. *The presence of moisture, if it does not result in explosive spalling, increases fire resistance.*

Materials having a 15 percent moisture content will have greater fire resistance than those having 4 percent moisture content at the time of fire exposure.

Rule 9. *Load-supporting elements, such as beams, girders and joists, yield higher fire endurance when subject to fire endurance tests as parts of floor, roof, or ceiling assemblies than they would when tested separately.*

A wood joist performs better when it is incorporated in a floor/ceiling assembly, than tested by itself under the same load.

Rule 10. *The load-supporting elements (beams, girders, joists, etc.) of a floor, roof, or ceiling assembly can be re-placed by such other load-supporting elements which, when tested separately, yielded fire endurance not less than that of the assembly.*

A joist in a floor assembly may be replaced by another type of joist having a fire resistance rating not less than that of the assembly.

¹ T.Z. Harmathy. "Ten Rules of Fire Endurance Rating". *Fire Technology*, Vol. 1, No. 2. May 1965, pp 93-102.