

DESIGNING FOR LATERAL-TORSIONAL STABILITY IN WOOD MEMBERS

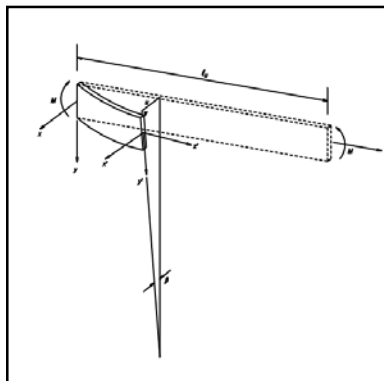

$$M_{ocr} = \frac{\pi}{l_u} \sqrt{EI_y GJ}$$



TECHNICAL REPORT 14

The American Wood Council (AWC) is the wood products division of the American Forest & Paper Association (AF&PA). AF&PA is the national trade association of the forest, paper and wood products industry, representing member companies engaged in growing, harvesting and processing wood and wood fiber, manufacturing pulp, paper and paperboard products from both virgin and recycled fiber, and producing engineered and traditional wood products. For more information see www.afandpa.org.

While every effort has been made to insure the accuracy of the information presented, and special effort has been made to assure that the information reflects the state-of-the-art, neither the American Forest & Paper Association nor its members assume any responsibility for any particular design prepared from this publication. Those using this document assume all liability from its use.

Copyright © 2003
American Forest & Paper Association, Inc.

American Wood Council
1111 19th St., NW, Suite 800
Washington, DC 20036
202-463-4713
awcinfo@afandpa.org
www.awc.org

TABLE OF CONTENTS

	<u>Page</u>
Table of Contents	i
List of Figures	ii
List of Tables	ii
Nomenclature	iv
Part I: Basic Concept of Lateral-Torsional Buckling	
1.1 Introduction.....	1
1.2 Background.....	1
1.3 History of the NDS Beam Stability Equations	6
1.4 Equivalent Moment Method for Design of Wood Bending Members	8
Part II: Design Method for Lateral-Torsional Buckling	
2.1 Conditions of Lateral Support.....	10
2.2 Comparison of New Calculation Method and Experimental Data	13
Part III: Example Problems	
3.1 Example 3.1 – Beams Braced at Intermediate Points.....	14
3.2 Example 3.2 – Continuous Span Beams	15
3.3 Example 3.3 – Cantilevered Joists.....	17
References	19
Appendix A: Derivation of Lateral-Torsional Buckling Equations	21
Appendix B: Derivation of 2001 NDS Beam Stability Provisions	31
Appendix C: Derivation of Rectangular Beam Equations	35
Appendix D: Graphical Representation of Wood Beam Stability Provisions	37

LIST OF FIGURES

	<u>Page</u>
Figure 1 Lateral-Torsional Buckling of a Beam	1
Figure 2 Comparison of New Calculation Method with Test Data	13
Figure A1 Lateral-Torsional Buckling of a Beam (three views)	21

LIST OF TABLES

	<u>Page</u>
Table 1 Comparison of Equivalent Moment Factor Approach with NDS Effective Length Provisions (for beams loaded through the neutral axis)	8
Table 2 C_b and k factors for Different Loading Conditions	12

NOMENCLATURE

C_b	= equivalent moment factor for different loading and support conditions
C_e	= load eccentricity factor
C_{fix}	= end fixity adjustment = 1.15
C_L	= beam stability factor
C_w	= warping constant
d	= depth of the member
E	= modulus of elasticity
E'_{y05}	= adjusted modulus of elasticity for bending about the weak axis at the 5 th percentile
G	= torsional shear modulus
G'_{t05}	= adjusted torsional shear modulus at the 5 th percentile
J	= torsional constant for the section
k	= constant based on loading and support conditions
I_x	= moment of inertia in the strong-axis (x-direction)
I_y	= moment of inertia in the weak-axis (y-direction)
l_e	= effective length which equals the unbraced length adjusted for specific loading and support conditions
l_u	= unbraced length
M'	= adjusted moment resistance
M^*	= moment resistance for strong axis bending multiplied by all applicable factors except C_{fu} , C_V , and C_L
M_1	= minimum end moment
M_2	= maximum end moment
M_A	= absolute value of moment at $l_u/4$
M_B	= absolute value of moment at $l_u/2$
M_C	= absolute value of moment at $3l_u/4$
M_{cr}	= critical buckling moment for specific loading and support conditions
M_{max}	= absolute value of maximum moment
M_{ocr}	= critical moment for the reference case (simply-supported beam under a constant moment)
γ	= cross-section slenderness adjustment = $1 - I_y/I_x$

Part I: Basic Concepts of Lateral-Torsional Buckling

1.1 INTRODUCTION

Lateral-torsional buckling is a limit state where beam deformation includes in-plane deformation, out-of-plane deformation and twisting. The load causing lateral instability is called the elastic lateral-torsional buckling load and is influenced by many factors such as loading and support conditions, member cross-section, and unbraced length. In the 2001 and earlier versions of the *National Design Specification® (NDS®) for Wood Construction* [1] the limit state of lateral torsional buckling is addressed using an effective length format whereby unbraced lengths are adjusted to account for load and support conditions that influence the lateral-torsional buckling load. Another common format uses an equivalent moment factor to account for these conditions. This report describes the basis of the current effective length approach used in the *NDS* and summarizes the equivalent uniform moment factor approach; provides a comparison between the two approaches; and proposes modification to *NDS* design provisions.

1.2 BACKGROUND

Design of an unbraced beam requires determination of the minimum moment which induces buckling. When a beam--one that is braced at its ends to prevent twisting at bearing points, but

which is otherwise unbraced along its length--is loaded in bending about the strong axis so that lateral torsional buckling is induced, three equilibrium equations may be written for the beam in its displaced position: one equation associated with strong axis bending; one equation associated with weak axis bending, and one equation associated with twisting (see Figure 1). Using these equations of equilibrium, a set of differential equations can be developed which, when solved, provides the critical moment, M_{cr} . A closed-form solution for the case of a simply-supported beam under a constant moment has been widely discussed and derivations can be found in the literature and are provided in Appendix A. The critical moment, M_{ocr} , for this reference case of a simply-supported beam under constant moment is given by:

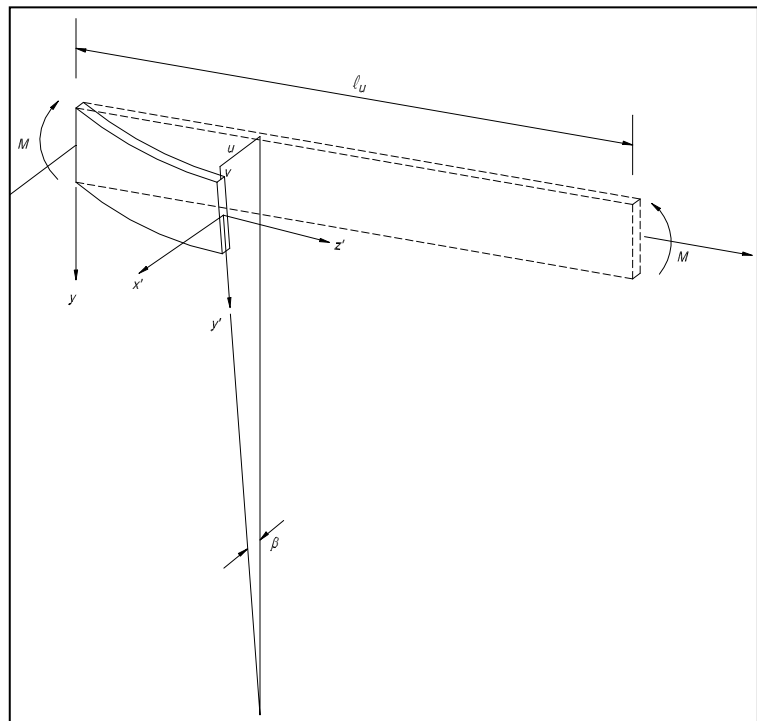

Figure 1. Lateral-Torsional Buckling of a Beam

$$M_{ocr} = \frac{\pi}{l_u} \sqrt{EI_y GJ} \quad (1)$$

where:

M_{ocr}	= critical moment for the reference case (simply-supported beam under a constant moment)
ℓ_u	= unbraced length
E	= modulus of elasticity
I_y	= moment of inertia in the weak-axis (y-direction)
G	= torsional shear modulus
J	= torsional constant for the section

Determination of the torsional constant, J , is beyond the scope of this document. However, equations for determining the value of J for common shapes are provided in the literature [2][3][6].

1.2.1 Effect of Beam Slenderness

Equation 1 was derived for slender beams where the in-plane flexural rigidity (EI_x) is much larger than the out-of-plane flexural rigidity (EI_y). Federhofer and Dinnik [2] found this assumption to be conservative for less slender beams. To adjust for this conservatism in less slender beams where the flexural rigidities in each direction are of the same order of magnitude, Kirby and Nethercot [3] suggested dividing I_y by the term γ , where $\gamma = 1 - I_y/I_x$ and I_x is the moment of inertia about the strong-axis.

1.2.2 Effect of Loading and Support Conditions

Equation 1 applies to a single loading condition (simply-supported beam under a constant moment). Many other loading and beam support conditions are commonly found in practice for which the magnitude of the critical moment needs to be determined. A closed-form solution is not available for these conditions and differential equations found in the derivation must be solved by other means including solution by numerical methods, infinite series approximation techniques, finite element analysis, or empirically. Solutions for common loading and beam support conditions have been developed and are provided in design specifications and textbooks. Solution techniques used to solve several common loading conditions and approximation techniques used to estimate adjustments for other loading conditions are discussed in more detail in Appendix A.1.

1.2.2.1 Adjusting for Loading and Support Conditions

Two methods are used to adjust Equation 1 for different loading and support conditions. The *effective length approach* and the *equivalent moment factor approach*. Both of these methods adjust from a reference loading and support condition.

1.2.2.1.1 Effective Length Approach

The effective length approach adjusts the reference case critical moment, M_{ocr} , to other loading and support conditions by adjusting the unbraced length to an “effective length” as provided in Equation 2:

$$M_{cr} = \frac{\pi}{\ell_e} \sqrt{EI_y GJ} \quad (2)$$

where:

M_{cr}	= critical moment for specific loading and support conditions
ℓ_e	= effective length which equals the unbraced length adjusted for specific loading and support conditions

1.2.2.1.2 Equivalent Moment Factor Approach

The equivalent moment factor approach adjusts the reference case critical moment, M_{ocr} , to other loading and support conditions using an equivalent moment factor, C_b , as provided in Equation 3:

$$M_{cr} = C_b M_{ocr} \tag{3}$$

where:

C_b = equivalent moment factor

Prior to 1961, the steel industry used an effective length approach to distinguish between different loading and support conditions. In 1961, the American Institute of Steel Construction (AISC) adopted the equivalent moment factor approach. This approach expanded application of beam stability calculations to a wider set of loading and support conditions.

The empirical equation used for design of steel beams when estimating the equivalent moment factor, C_b , has changed over the last 40 years. The original equation for estimating C_b was:

$$C_b = 1.75 + 1.05 \left(\frac{M_1}{M_2} \right) + 0.3 \left(\frac{M_1}{M_2} \right)^2 \leq 2.3 \tag{4}$$

where:

M_1 = minimum end moment

M_2 = maximum end moment

Equation 4 provides accurate estimates of C_b in cases where the slope of the moment diagram is constant (a straight line) between braced points but does not apply to beams bent in reverse curvature. For this reason, it is only recommended for M_1/M_2 ratios which are negative (with single curvature i.e. $M_1/M_2 < 0$) [4].

Equation 5 was developed for cases where slope of the moment diagram is constant between braced points and better matches the theoretical solution for beams bent in single and reversed curvature [4]. This equation is of the form:

$$C_b = \frac{1}{0.6 - 0.4 \left(\frac{M_1}{M_2} \right)} \leq 2.5 \tag{5}$$

To address limitations of Equations 4 and 5 and to avoid misapplication of these equations, Kirby and Nethercot [3] proposed the following empirical equation which uses a moment-fitting method to estimate C_b :

$$C_b = \frac{12M_{\max}}{3M_A + 4M_B + 3M_C + 2M_{\max}} \tag{6}$$

where:

M_A = absolute value of moment at $\ell_u/4$

M_B = absolute value of moment at $\ell_u/2$

$$\begin{aligned} M_C &= \text{absolute value of moment at } 3\ell_u/4 \\ M_{\max} &= \text{absolute value of maximum moment} \end{aligned}$$

The following modified version of the Kirby and Nethercot equation appeared in AISC's 1993 *Load and Resistance Factored Design Specification for Structural Steel Buildings* [4]. This equation provides a lower bound across the full range of moment distributions in beam segments between points of bracing:

$$C_b = \frac{12.5M_{\max}}{2.5M_{\max} + 3M_A + 4M_B + 3M_C} \quad (7)$$

1.2.3 Effect of Load Position Relative to Neutral Axis

Equation 1 assumes that loading is through the neutral axis of the member. In cases where the load is above the neutral axis at an unbraced location, an additional moment is induced due to displacement of the top of the beam relative to the neutral axis. This additional moment due to torsional eccentricity reduces the critical moment. Similarly, a load applied below the neutral axis increases the critical moment. The design literature provides several means of addressing the effects of load position [2][5][6][10].

1.2.3.1 Adjusting for Load Position Relative to Neutral Axis

There are generally two methods used to adjust Equation 1 for load position relative to the neutral axis. One method adjusts the effective length previously discussed in 1.2.2.1.1. The second method uses a load eccentricity factor, C_e . Derivation of this factor has been reviewed in the literature [2][10] and is provided in Appendix A.2. The eccentricity factor takes the form of:

$$C_e = \sqrt{\eta^2 + 1} - \eta \quad (8)$$

$$\eta = \frac{kd}{2\ell_u} \sqrt{\frac{EI_y}{GJ}} \quad (9)$$

where:

$$\begin{aligned} C_e &= \text{load eccentricity factor} \\ k &= \text{constant based on loading and support conditions} \\ d &= \text{depth of the member} \end{aligned}$$

Flint [10] demonstrated numerically, that Equation 9 is accurate for a single concentrated load case where η lies between -0.34 and +1.72 (negative values indicate loads applied below the neutral axis and positive values indicate loads applied above the neutral axis). Limiting η to a maximum value of 1.72 limits C_e to a minimum value of 0.27.

1.2.4 Non-Rectangular Beams

Equation 1 under-predicts the critical moment for beams with non-rectangular cross-sections, such as I-beams. For more accurate predictions of the critical moment for simply supported non-rectangular beams under uniform moment, an additional term can be added to account for increased torsional resistance provided by warping of the cross-section [2]:

$$M_{ocr} = \frac{\pi}{\ell_u} \sqrt{EI_y GJ + \left(\frac{\pi E}{\ell_u}\right)^2 I_y C_w} \quad (10)$$

where:

C_w = warping constant

Procedures for calculating the warping constant, C_w , are beyond the scope of this document; however, procedures exist in the literature [2][6]. For many cross-sections, Equation 10 is overly complicated and can be simplified by conservatively ignoring the increased resistance provided by warping.

1.2.5 Cantilevered and Continuous Beams

Currently, there is a lack of specific lateral-torsional buckling design provisions for cantilevered and continuous beams. For cantilevered beams, direct solutions for a few cases have been developed and are available in the literature [2][3][4][6][11] and have been reprinted in Tables 1 and 2. However, for other load cases of cantilevered beams which are unbraced at the ends, approximation equations, such as Equation 7, do not apply. For these cases, designers have used conservative values for C_b and k . Derivation of C_b and k values for additional cantilevered load cases is beyond the scope of this report.

Provisions in this report also apply to continuous beams. However, since there are various levels of bracing along the compression edge of continuous beams and at interior supports, applying beam stability provisions may be confusing. As a result, most continuous beams are designed with additional full-height bracing at points of interior bearing.

To clarify how to use the provisions in this report to design continuous beams, it must be clear that the derivation of Equation 1 assumes that there is no external lateral load applied about the weak axis of the beam through bracing, supports, or otherwise. Also, it assumes that supports at the ends of members are laterally braced. Additional considerations are required for continuous beams. A continuous beam can be assumed to be braced adequately at interior supports if provisions are made to prevent displacement of the tension edge of the beam relative to the compression edge. Such provisions include providing full-height blocking, providing both tension and compression edge sheathing at the interior supports, or having one edge braced by sheathing and the other edge braced by an adequately designed wall. Otherwise, the designer has to use judgment as to whether to consider the beam to have an unbraced length equal to the full length of the member between points of bracing, an unbraced length measured from the inflection point, or an unbraced length that is between these two conditions. The designer's judgment should consider the sheathing stiffness and the method of attachment to the beam. A beam that is about to undergo lateral torsional buckling develops bending moments about its weak axis and these moments can extend beyond inflection points associated with strong axis bending. Further research is being considered to quantify the roles that tension side bracing and inflection points have on the tendency for lateral torsional buckling.

1.2.6 Beam Bracing

Derivation of equations in this report are based on the assumption that member ends at bearing points are braced to prevent rotation (twisting), even in members otherwise considered to be unbraced. In addition, effective beam bracing must prevent displacement of the beam

compression edge relative to the beam tension edge (i.e. twisting of the beam). There are two types of beam bracing, lateral and torsional. Lateral bracing, such as sheathing attached to the compression edge of a beam, is used to minimize or prevent lateral displacement of the beam, thereby reducing lateral displacement of the compression edge of the beam relative to the tension edge. Torsional bracing, such as cross-bridging or blocking, is used to minimize or prevent rotation of the cross-section. Both bracing types can be designed to effectively control twisting of the beam; however, steel bracing systems that provide combined lateral and torsional bracing, such as a concrete slab attached to a steel beam compression edge with shear studs, have been shown to be more effective than either lateral or torsional bracing acting alone (Mutton and Trahair [7a]) (Tong and Chen [7b]). Design of lateral and/or torsional bracing for wood beams is currently beyond the scope of this document; however, further research is being considered to quantify and develop design provisions for lateral and torsional bracing systems. Guidance for steel bracing systems is provided in Yura [5] and Galambos [6].

1.2.6.1 Lateral Bracing

There are four general types of lateral bracing systems; continuous, discrete, relative, and lean-on. The effectiveness and design of lateral bracing is a function of bracing type, brace spacing, beam cross-section and induced moment. Lateral bracing is most effective when attached to the compression edge and has little effect when bracing the neutral axis (Yura [5]).

1.2.6.2 Torsional Bracing

There are two general types of torsional bracing; continuous and discrete. The effectiveness and design of torsional bracing is significantly affected by the cross-sectional resistance to twisting.

1.3 HISTORY OF THE NDS BEAM STABILITY EQUATIONS

In early editions of the *NDS*, beam stability was addressed using prescriptive bracing provisions. The *effective length approach* (see 1.2.2.1.1) for design of bending members was introduced in the 1977 *NDS*. Basic load and support cases addressed in the 1977 *NDS* were as follows:

1. A simply-supported beam with:
 - uniformly-supported load – unbraced along the loaded edge
 - a concentrated load at midspan – unbraced at the point of load
 - equal end moments (opposite rotation)
2. A cantilevered beam with:
 - uniformly distributed load- unbraced along the loaded edge
 - concentrated load at the free-end – unbraced at the point of load
3. A conservative provision for all other load and support cases

Provisions for these load and support conditions were derived from a report by Hooley and Madsen [7]. Hooley and Madsen used a study by Flint [10] to derive simple effective length equations to adjust the unbraced lengths for the above mentioned load cases and loads applied at the top of beams. In addition, Hooley and Madsen recommended that the unbraced length be increased 15% to account for imperfect torsional restraint at supports. Derivation of these provisions and comparisons are presented in Appendix B.

In 1991, the *NDS* provisions were expanded to cover a wider range of load cases based on a study by Hooley and Devall [8]. In addition, some load cases were changed [9].

1.3.1 Comparison Between ℓ_e Approach and C_b Approach

In the *NDS* provisions which use an effective length approach to adjust for different load and support conditions, the buckling stress, F_{bE} , is calculated using a modified form of Equation 2 which has been simplified for rectangular beams (see Appendix B). The equation was derived for a simply-supported beam with a concentrated load at midspan - unbraced at point of load, as provided in Equation 11. Additional loading conditions were derived and the effective length equations were adjusted to this reference condition.

$$M_{cr} = \frac{2.40EI_y}{\ell_e} \quad (11)$$

where:

$$\ell_e = 1.37\ell_u, \text{ for a simply-supported beam with a concentrated load at midspan} \\ \text{- unbraced at point of load}$$

For the reference condition (simply-supported beam with a constant moment) in Equation 1, the *NDS* effective length equation is: $\ell_e = 1.84 \ell_u$. The equivalent moment factor approach and the *NDS* effective length approach can be compared by recognizing that, for the reference condition, $C_b = 1.0$ and $\ell_e = 1.84 \ell_u$. Therefore, $C_b = 1.84 \ell_u / \ell_e$. Solving for ℓ_e yields:

$$\ell_e = \frac{1.84}{C_b} \ell_u \quad (12)$$

Table 1 compares effective lengths derived using Equations 7 and 12 and effective lengths tabulated in the *2001 NDS*. It should be noted that some of the *NDS* effective length equations are inconsistent with estimates from Equations 7 and 12. In cases where a load can be applied on the compression edge of a beam, *NDS* Table 3.3.3 assumes that the beam is always loaded on the compression edge. For cases not explicitly covered in Table 3.3.3 of the *NDS*, the most severe effective length assumption applies (i.e. $1.84\ell_u < \ell_e < 2.06\ell_u$). In addition, Hooley and Duvall assumed that effective lengths for beams loaded at multiple points could be estimated by interpolating between the single concentrated load case and the uniform load case. This assumption is inconsistent with assumptions used in the derivation of the equations and the equivalent moment factors.

**Table 1. Comparison of Equivalent Moment Factor Approach with NDS Effective Length Provisions
(for beams loaded through the neutral axis)**

Loading Condition	Lateral Support @ Load	Equivalent Moment Factor Approach		2001 NDS Table 3.3.3
		C_b (Eqn. 7)	Effective Length, l_e (Eqn. 12)	Effective Length, l_e (NDS tabulated values)
Single Span Beams				
Uniformly distributed load	No	1.13	$l_e = 1.63l_u$	$l_e = 1.63l_u + 3d$
Concentrated load @ center	No	1.35	$l_e = 1.37l_u$	$l_e = 1.37l_u + 3d$
	Yes	1.67	$l_e = 1.10l_u$	$l_e = 1.11l_u$
Two equal conc. loads @ 1/3 points	No	1.14	$l_e = 1.61l_u$	$1.84l_u < l_e < 2.06l_u$
	Yes	1.00	$l_e = 1.84l_u$	$l_e = 1.68l_u$
Three equal conc. loads @ 1/4 points	No	1.14	$l_e = 1.61l_u$	$1.84l_u < l_e < 2.06l_u$
	Yes	1.11	$l_e = 1.66l_u$	$l_e = 1.54l_u$
Four equal conc. loads @ 1/5 points	No	1.14	$l_e = 1.62l_u$	$1.84l_u < l_e < 2.06l_u$
	Yes	1.00	$l_e = 1.84l_u$	$l_e = 1.68l_u$
Five equal conc. loads @ 1/6 points	No	1.14	$l_e = 1.62l_u$	$1.84l_u < l_e < 2.06l_u$
	Yes	1.05	$l_e = 1.75l_u$	$l_e = 1.73l_u$
Six equal conc. loads @ 1/7 points	No	1.13	$l_e = 1.63l_u$	$1.84l_u < l_e < 2.06l_u$
	Yes	1.00	$l_e = 1.84l_u$	$l_e = 1.78l_u$
Seven equal conc. loads @ 1/8 points	No	1.13	$l_e = 1.63l_u$	$1.84l_u < l_e < 2.06l_u$
	Yes	1.03	$l_e = 1.79l_u$	$l_e = 1.84l_u$
Eight or more equal conc. loads @ equal spacings	No	1.13	$l_e = 1.63l_u$	$1.84l_u < l_e < 2.06l_u$
	Yes	1.00	$l_e = 1.84l_u$	$l_e = 1.84l_u$
Equal end moments (opposite rotation)	-	1.00	$l_e = 1.84l_u$	$l_e = 1.84l_u$
Equal end moments (same rotation)	-	2.30	$l_e = 0.80l_u$	$1.84l_u < l_e < 2.06l_u$
Cantilever Beams				
Uniformly distributed load	No	2.05	$l_e = 0.90l_u$	$l_e = 0.90l_u + 3d$
Concentrated load @ unbraced end	No	1.28	$l_e = 1.44l_u$	$l_e = 1.44l_u + 3d$

d = depth of the member

1.4 EQUIVALENT MOMENT METHOD FOR DESIGN OF WOOD BENDING MEMBERS

Design provisions for lateral-torsional buckling of wood bending members are contained in the general design provisions for bending in the *NDS* [1] and *ASCE 16* [4]. In the *NDS*, an adjustment is made to the bending stress, F_b^* , by applying a beam stability factor, C_L , that accounts for the ratio of the buckling stress, F_{bE} , to the bending stress, F_b^* . Adjustments for loading, support, and load eccentricity conditions are made to F_{bE} through use of tabulated *effective lengths*, l_e (see 1.2.2.1.1).

In *ASCE 16*, lateral-torsional buckling is addressed in a similar manner. An adjustment is made to the strong-axis bending moment, M_x^* , by applying a beam stability factor, C_L , that accounts for the ratio of the elastic lateral buckling moment, M_e , to the strong-axis bending moment, M_x^* . Note that the elastic lateral buckling moment, M_e , is equivalent to the critical moment, M_{cr} , derived in earlier sections of this document. For prismatic beams, adjustments for loading, support, and load eccentricity conditions are made to M_e through the use of tabulated *effective lengths*, ℓ_e . For non-prismatic beams, adjustments for loading and support conditions are made using *equivalent moment factors*, C_b (see 1.2.2.1.2). Values for C_b are calculated using Equation 4 (see 1.2.2.1.2 for limitations on use of Equation 4).

A new, more comprehensive method for design of wood bending members is provided in Part II of this document. The new method uses the *ASCE 16* format of applying a beam stability factor, C_L , to the strong-axis bending moment, M_x^* to account for the ratio M_{cr} (also known as the elastic lateral buckling moment, M_e), to M_x^* . This method incorporates the use of equivalent moment factors (1.2.2.1.2) and load eccentricity factors (see 1.2.3.1) to account for the effects of loading, support, and load eccentricity effects on the critical moment, M_{cr} .

Part II: Design Method for Lateral-Torsional Buckling

2.1 CONDITIONS OF LATERAL SUPPORT

2.1.1 General

When a bending member is bent about its strong axis and the moment of inertia about the strong axis (I_x) exceeds the moment of inertia about the weak axis (I_y), the weak axis shall be braced in accordance with 2.1.2 or the moment capacity in the strong axis direction shall be reduced per 2.1.3.

2.1.2 Bracing of Compression Edge

The compression edge of a bending member shall be braced throughout its length to prevent lateral displacement and the ends at points of bearing shall have lateral support to prevent rotation. The adjusted moment resistance, M' , about the strong-axis of a member laterally braced as noted above is:

$$M' = M^* \quad (13)$$

where:

$$\begin{aligned} M' &= \text{adjusted moment resistance} \\ M^* &= \text{moment resistance for strong axis bending multiplied by all applicable factors except } C_{fu}, C_V, \text{ and } C_L. \end{aligned}$$

2.1.3 Moment Resistance of Members Without Full Lateral Support

The adjusted moment resistance about the strong axis of members that are not laterally braced for their full length or a portion thereof is:

$$M' = C_L M^* \quad (14)$$

where:

$$C_L = \text{beam stability factor (2.1.3.1)}$$

2.1.3.1 Beam Stability Factor

The beam stability factor, C_L , shall be calculated as:

$$C_L = \frac{1 + \alpha_b}{1.90} - \sqrt{\left(\frac{1 + \alpha_b}{1.90}\right)^2 - \frac{\alpha_b}{0.95}} \quad (15)$$

$$\alpha_b = \frac{M_{cr}}{M^*} \quad (16)$$

where:

$$M_{cr} = \text{critical buckling moment}$$

When the volume effect factor, C_V , is less than 1.0, the lesser of C_L or C_V shall be used to determine the adjusted moment resistance.

2.1.3.2 Critical Buckling Moment

The critical buckling moment, M_{cr} , shall be calculated as:

$$M_{cr} = \frac{\pi C_b C_e}{C_{fix} \ell_u} \sqrt{\frac{E'_{y05} I_y G'_{t05} J}{\gamma}} \quad (17)$$

where:

- C_b = equivalent moment factor for different loading and support conditions (2.1.3.3)
- C_e = load eccentricity factor for top-loaded beams (2.1.3.4)
- C_{fix} = end fixity adjustment (see 1.3) = 1.15
- ℓ_u = unbraced length
- E'_{y05} = adjusted modulus of elasticity for bending about the weak axis at the fifth percentile
- I_y = weak axis moment of inertia
- G'_{t05} = adjusted torsional shear modulus at the fifth percentile
- J = torsional constant
- γ = cross-section slenderness adjustment = $1 - I_y/I_x$

For rectangular bending members, the critical buckling moment shall be permitted to be calculated as (see Appendix C.1 for derivation):

$$M_{cr} = \frac{1.3 C_b C_e E'_{y05} I_y}{\ell_u} \quad (18)$$

2.1.3.3 Equivalent Moment Factor

The equivalent moment factor, C_b , for different loading and support conditions shall be taken from Table 2 or, for beam segments between points of bracing, calculated as:

$$C_b = \frac{12.5 M_{max}}{3 M_A + 4 M_B + 3 M_C + 2.5 M_{max}} \quad (19)$$

where:

- M_{max} = absolute value of maximum moment
- M_A = absolute value of moment at $\ell/4$
- M_B = absolute value of moment at $\ell/2$
- M_C = absolute value of moment at $3\ell/4$

For all loading and support conditions, C_b is permitted to be conservatively taken as 1.0.

2.1.3.4 Load Eccentricity Factor for Beams Loaded on the Compression-Side

When a bending member is loaded from the tension-side or through the neutral axis, $C_e=1.0$ which is conservative for cases where the bending member is loaded from the tension-side [2][7][10]. When a bending member is loaded from the compression-side of the neutral axis and is braced at the point of load, $C_e=1.0$. When a bending member is loaded from the compression-side of the neutral axis and is unbraced at the point of load, the load eccentricity factor shall be calculated as:

$$C_e = \sqrt{\eta^2 + 1} - \eta \quad (20)$$

where:

$$\eta = \frac{kd}{2\ell_u} \sqrt{\frac{E'_{y05} I_y}{G'_{t05} J\gamma}} \quad (21)$$

k = constant based on loading and support conditions (Table 2). For all loading cases, k can conservatively be taken as 1.72.

The minimum value of C_e need not be taken as less than 0.27.

For rectangular bending members, η shall be permitted to be calculated as (see Appendix C.2 for derivation):

$$\eta = \frac{1.3kd}{\ell_u} \quad (22)$$

Table 2. C_b and k Factors for Different Loading Conditions

Loading Condition	Laterally Braced @ point of loading	Laterally Unbraced @ point of loading	
	C_b	C_b	k
Single Span Beams			
Concentrated load @ center	1.67	1.35	1.72
Two equal conc. loads @ 1/3 points	1.00	1.14	1.63
Three equal conc. loads @ 1/4 points	1.11	1.14	1.45
Four equal conc. loads @ 1/5 points	1.00	1.14	1.51
Five equal conc. loads @ 1/6 points	1.05	1.14	1.45
Six equal conc. loads @ 1/7 points	1.00	1.13	1.47
Seven equal conc. loads @ 1/8 points	1.03	1.13	1.44
Eight or more equal conc. loads @ equal spacings	1.00	1.13	1.46
Uniformly distributed load	1.00 ¹	1.13	1.44
Equal end moments (opposite rotation)	1.00	---	---
Equal end moments (same rotation)	2.30	---	---
Cantilever Beams			
Concentrated load @ end	1.67	1.28	1.00
Uniformly distributed load	1.00 ¹	2.05	0.90

¹ The unbraced length, ℓ_u , in these cases is zero; therefore, the beam is considered fully-braced with $C_L=1.0$.

2.1.3.5 Special Design Considerations for Cantilevered Beams

For cantilevered beams, direct solutions for two cases have been developed and are provided in Table 2; however, for other load cases of cantilevered beams which are unbraced at the ends, Equation 18 does not apply. For these cases, designers are required to use conservative values of $C_b = 1.0$ and $k = 1.00$.

2.1.3.6 Special Design Considerations for Continuous Beams

For continuous beams, values for C_b and k vary depending on the location of bracing. A continuous beam can be assumed to be adequately braced at an interior support if full-height blocking or tension and compression edge bracing at supports are used to prevent displacement of the tension edge of the beam relative to the compression edge. Otherwise the beam should be designed as unbraced for the full length of the beam between points of bracing.

2.2 COMPARISON OF NEW CALCULATION METHOD AND EXPERIMENTAL DATA

In 1961, Hooley and Madsen tested 33 beams with various b/d ratios, loading conditions, and support conditions [7]. Using behavioral equations taken from the design procedure outlined in 2.1, the Hooley and Madsen data was analyzed. A comparison of the predicted bending strength with the observed bending strength is plotted in Figure 2.

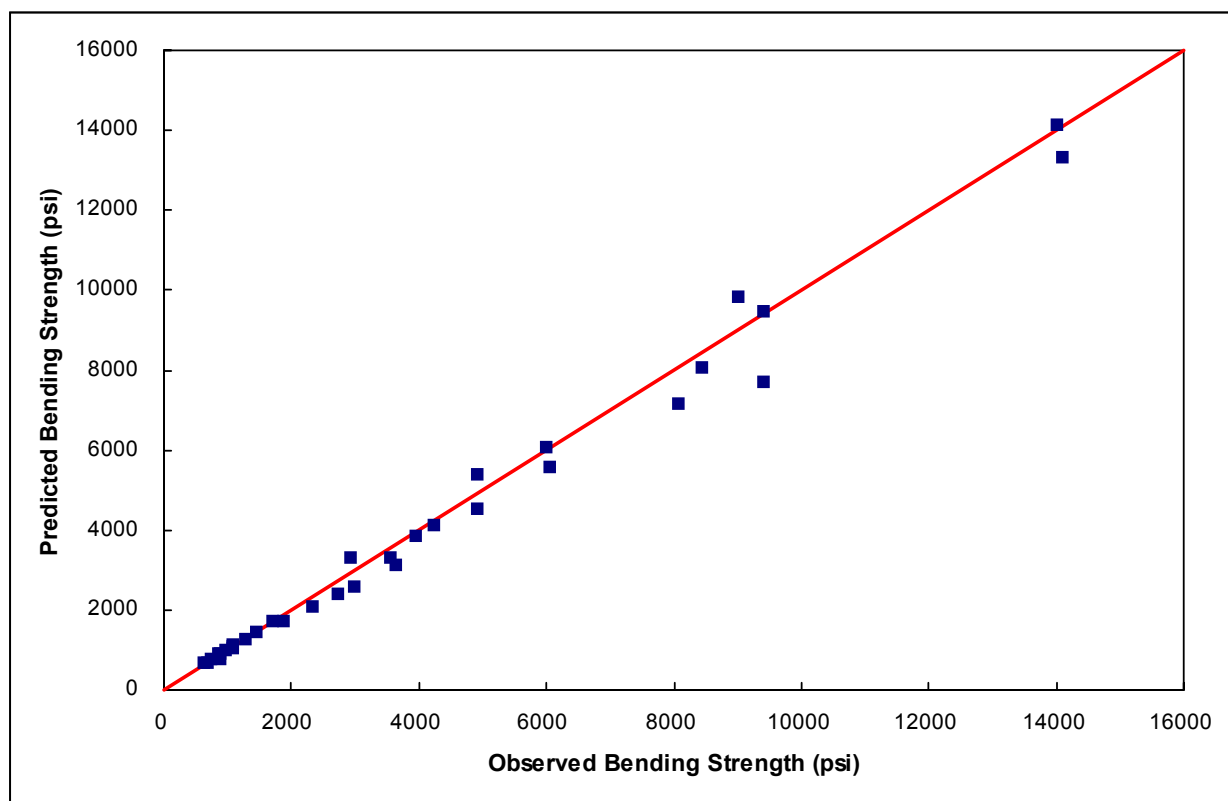

Figure 2. Comparison of New Calculation Method with Test Data

Part III: Example Problems

Example problems are based on the application of the new beam stability provisions in Part II.

Example 3.1 - Beams Braced at Intermediate Points

Problem Statement: Design a glulam beam to be used as a ridge beam braced with roof joists spaced at 4 feet on center along its length.

Given: The span of the ridge beam, ℓ , is 28 feet. The design loads are $w_{\text{dead}} = 75$ plf and $w_{\text{snow}} = 300$ plf. The roof joists are attached to the sides of the ridge beam providing adequate bracing of the beam; therefore, for calculating the beam buckling moment the unbraced length of the beam, ℓ_u , can be assumed to be 48 inches.

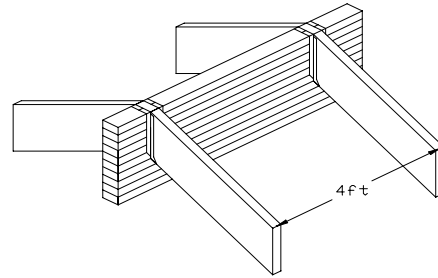

Calculate the maximum induced moment:

$$M_{\text{max}} = (w_{\text{dead}} + w_{\text{snow}}) \ell^2 / 8 = (375)(28^2) / 8 = 36,750 \text{ ft-lb}$$

Select a 2½" x 21" 24F-V4 Douglas fir glulam beam:

$$\begin{aligned} F_{\text{bx}} &= 2,400 \text{ psi} \\ E_y &= 1,600,000 \text{ psi} \end{aligned}$$

Calculate properties:

$$\begin{aligned} F_{\text{bx}}^* &= F_{\text{bx}} C_D C_M C_t C_{fu} C_i \\ &= (2,400)(1.15)(1.0)(1.0)(1.0)(1.0) = 2,760 \text{ psi} \\ E'_{y05} &= E_y (1 - 1.645 \text{COV}_E) (\text{Adjust to shear-free E}) / (\text{Safety Factor}) \\ &= (1,600,000)[1 - 1.645(0.11)](1.05) / (1.66) = 1,600,000 / 1.93 = 829,000 \text{ psi} \end{aligned}$$

$$\begin{aligned} S_x &= bd^2 / 6 = (2.5)(21^2) / 6 = 183.8 \text{ in.}^3 \\ I_x &= bd^3 / 12 = (2.5)(21^3) / 12 = 1929 \text{ in.}^4 \\ I_y &= db^3 / 12 = (21)(2.5^3) / 12 = 27.34 \text{ in.}^4 \\ C_V &= \frac{(21/\ell)^{1/x} (12/d)^{1/x} (5.125/b)^{1/x}}{(21/28)^{0.1} (12/21)^{0.1} (5.125/2.5)^{0.1}} \quad \text{where } x = 10 \\ &= 0.9871 \end{aligned}$$

Calculate buckling moment capacity:

$$\begin{aligned} C_b &= 1.00 \quad (\text{assuming 6 roof joists, from Table 2}) \\ C_e &= 1.00 \quad (\text{assuming braced at point of load}) \\ M_{\text{cr}} &= 1.3 C_b C_e E'_{y05} I_y / \ell_u = 1.3(1.0)(1.0)(829,000)(27.34) / (48) = 613,800 \text{ in-lb} \quad \text{or} \quad 51,150 \text{ ft-lb} \end{aligned}$$

Calculate allowable bending moment:

$$\begin{aligned} M^* &= F_{\text{bx}}^* S_x = (2,760)(183.8) = 507,300 \text{ in-lb} \quad \text{or} \quad 42,250 \text{ ft-lb} \\ \alpha_b &= M_{\text{cr}} / M^* = 51,150 / 42,250 = 1.21 \end{aligned}$$

$$C_L = \frac{1 + \alpha_b}{1.9} - \sqrt{\left(\frac{1 + \alpha_b}{1.9}\right)^2 - \frac{\alpha_b}{0.95}} = \frac{1 + 1.21}{1.9} - \sqrt{\left(\frac{1 + 1.21}{1.9}\right)^2 - \frac{1.21}{0.95}} = .88$$

$$M' = M^* (\text{lesser of } C_V \text{ or } C_L) = (42,250)(0.88) = 37,250 \text{ ft-lb}$$

Structural Check: $M' \geq M_{\text{max}}$ $37,250 \text{ ft-lb} \geq 36,750 \text{ ft-lb}$ ✓

Example 3.2 - Continuous Span Beams

Problem Statement: Determine C_b , k , and ℓ_u values for a two-span continuous beam subjected to a uniformly distributed gravity load. Compare these values for the following bracing conditions:

1. Top edge unbraced, interior bearing point braced.
2. Top edge unbraced, interior bearing point unbraced.

Given: The beam has two equal spans of length, ℓ . The value for C_b can be calculated for each case using Equation 18:

$$C_b = \frac{12.5M_{\max}}{3M_A + 4M_B + 3M_C + 2.5M_{\max}}$$

Case 1: The top edge of the beam is in compression from the end to the inflection point of the beam (0.75ℓ) and is unbraced. The interior bearing point is braced relative to the top tension edge of the beam. Therefore, this case has two unbraced lengths, ℓ_u , each spanning from the end of the beam to the interior support ($\ell_u = \ell$). Since a value for k has not been derived, assume $k=1.72$. The quarter-point moments for this case are as follows:

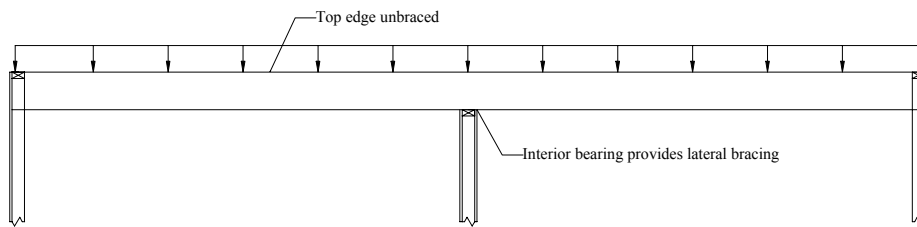

$$\begin{aligned} M_{\max} &= -0.1250w\ell^2 \text{ @ interior bearing} \\ M_A &= 0.0625w\ell^2 \text{ at } x=0.25\ell \\ M_B &= 0.0625w\ell^2 \text{ at } x=0.5\ell \\ M_C &= 0.0000 \text{ at } x=0.75\ell \end{aligned}$$

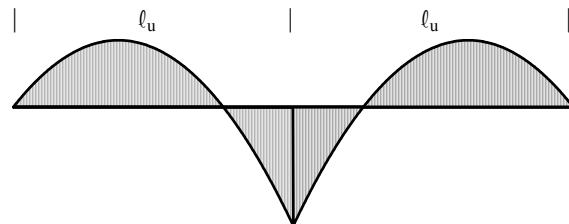

Case 1. Top edge unbraced, interior bearing point braced

$$C_b = \frac{12.5(0.1250w\ell^2)}{3(0.0625w\ell^2) + 4(0.0625w\ell^2) + 3(0.0000w\ell^2) + 2.5(0.1250w\ell^2)} = 2.08$$

Case 2: The top edge of the beam is in compression from the end to the inflection point of the beam (0.75ℓ) and is unbraced. The interior bearing point is unbraced. Therefore, this case has one unbraced length, ℓ_u , which spans between the ends of the beam ($\ell_u = 2\ell$). Since a value for k has not been derived, assume $k=1.72$. The quarter-point moments for this case are as follows:

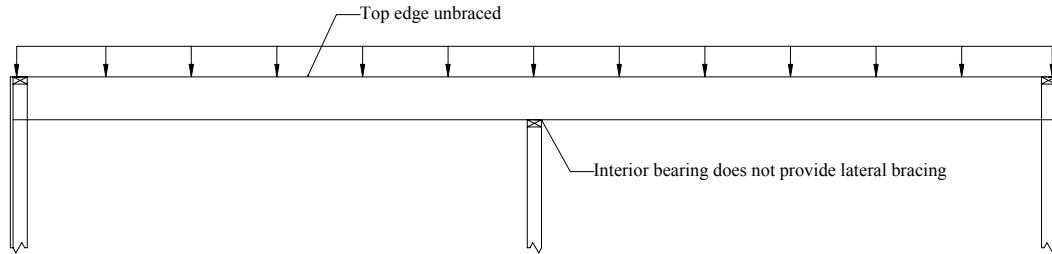

$$\begin{aligned} M_{\max} &= -0.1250w\ell^2 \text{ @ interior bearing} \\ M_A &= 0.0625w\ell^2 \text{ at } x=0.5\ell \\ M_B &= -0.1250w\ell^2 \text{ at } x=\ell \\ M_C &= 0.0625w\ell^2 \text{ at } x=1.5\ell \end{aligned}$$

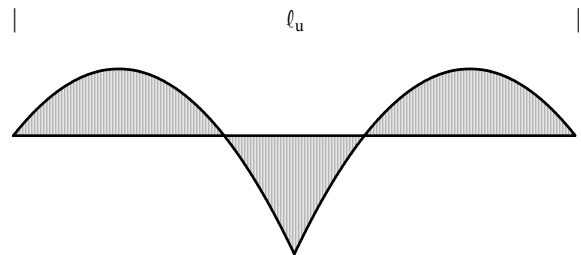

Case 2. Top edge unbraced, interior bearing point unbraced

$$C_b = \frac{12.5(0.1250w\ell^2)}{3(0.0625w\ell^2) + 4(0.1250w\ell^2) + 3(0.0625w\ell^2) + 2.5(0.1250w\ell^2)} = 1.32$$

Note: This example assumes that there are no external lateral forces being resisted by the beam and/or interior support. If lateral forces are being resisted by the beam in the weak axis direction, a different analysis including the effects on beam stability, should be considered.

Example 3.3 - Cantilevered Ceiling Joists

Problem Statement: Determine the impact of bracing the end of a cantilevered ceiling joist that is unbraced on the compression (bottom) edge.

Given: A ceiling is designed with a cantilevered span of 4 feet. The beam is laterally braced at the supporting walls. The cantilever is supporting a concentrated load at the end of the cantilever. Design the cantilever with #2 Southern pine 2x12 joists spaced at 2 feet on center.

From Table 4B of the NDS Supplement:

$$F_{bx} = 975 \text{ psi}$$

$$E_y = 1,600,000 \text{ psi}$$

Calculate properties:

$$F_{bx}^* = F_{bx} C_D C_M C_t C_F C_{fu} C_i C_r = (975)(1.0)(1.0)(1.0)(1.0)(1.0)(1.15) = 1,121 \text{ psi}$$

$$E'_{y05} = E_y (1 - 1.645 COV_E) (\text{Adjust to shear-free } E) / (\text{Safety Factor}) = (1,600,000)[1 - 1.645(0.25)](1.03) / (1.66) = 1,600,000 / 2.74 = 584,500 \text{ psi}$$

$$S_x = bd^2/6 = (1.5)(11.25^2)/6 = 31.64 \text{ in.}^3$$

$$I_x = bd^3/12 = (1.5)(11.25^3)/12 = 178.0 \text{ in.}^4$$

$$I_y = db^3/12 = (11.25)(1.5^3)/12 = 3.164 \text{ in.}^4$$

Without End Bracing

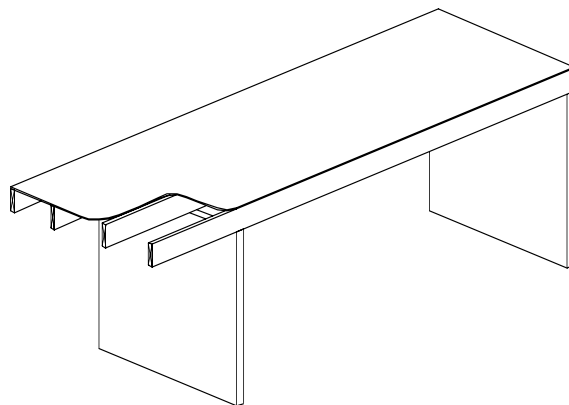

Calculate buckling moment capacity:

$$C_b = 1.28 \quad k = 1.0 \quad (\text{from Table 2})$$

$$\eta = 1.3kd/\ell_u = 1.3(1.0)(11.25)/48 = 0.3047$$

$$C_e = (\eta^2 + 1)^{0.5} - \eta = (0.3047^2 + 1)^{0.5} - 0.3047 = 0.7407$$

$$M_{cr} = 1.3 C_b C_e E_{y05}' I_y / \ell_u = 1.3(1.28)(0.7407)(584,494)(3.164)/48 = 47,487 \text{ in-lb or } 3,957 \text{ ft-lb}$$

Calculate allowable bending moment:

$$M_x^* = F_{bx}^* S_x = (1,121)(31.64) = 35,468 \text{ in-lb or } 2,956 \text{ ft-lb}$$

$$\alpha_b = M_{cr}/M_x^* = 3,957/2,956 = 1.339$$

$$C_L = \frac{1 + 1.339}{1.9} - \sqrt{\left(\frac{1 + 1.339}{1.9}\right)^2 - \frac{1.339}{0.95}} = 0.905$$

$$M_x' = M_x^* C_L = (2,956)(0.905) = 2,676 \text{ ft-lb.}$$

With End Bracing

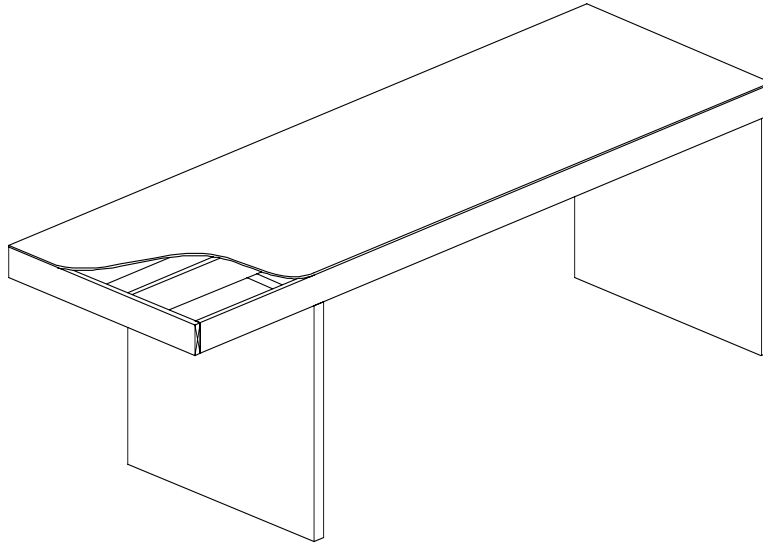

Calculate buckling moment capacity:

$$C_b = 1.67 \quad (\text{from Table 2})$$

$$C_e = 1.00 \quad (\text{assuming braced at point of load})$$

$$M_{cr} = 1.3 C_b C_e E_{y05}' I_y / \ell_u = 1.3(1.67)(1.00)(584,494)(3.164)/48 = 83,644 \text{ in-lb or } 6,970 \text{ ft-lb}$$

Calculate allowable bending moment:

$$M_x^* = F_{bx}^* S_x = (1,121)(31.64) = 35,468 \text{ in-lb or } 2,956 \text{ ft-lb}$$

$$\alpha_b = M_{cr}/M_x^* = 6,970/2,956 = 2.358$$

$$C_L = \frac{1 + 2.358}{1.9} - \sqrt{\left(\frac{1 + 2.358}{1.9}\right)^2 - \frac{2.358}{0.95}} = 0.966$$

$$M_x' = M_x^* C_L = (2,956)(0.966) = 2,857 \text{ ft-lb.}$$

Note: This example assumes that there are no external lateral forces being resisted by the beam and/or interior support. If lateral forces are being resisted by the beam in the weak axis direction, a different analysis including the effects on beam stability should be considered.

References

1. National Design Specification (NDS) for Wood Construction. American Forest & Paper Association. 2001.
2. Timoshenko, S. Theory of Elastic Stability. First Edition. McGraw-Hill Book Co., 1936.
3. Kirby, P. A. and Nethercot, D. A. Design for Structural Stability. Constrado Monographs, Granada Publishing, Suffolk, UK, 1979.
4. Load and Resistance Factor Design Specification for Structural Steel Buildings, AISC Manual of Steel Construction, Second Edition. American Institute of Steel Construction. 1993.
5. Galambos, T.V. Guide to Stability Design Criteria for Metal Structures. John Wiley & Sons, Inc. 1998.
6. Chen, W.F. and Lui, E.M. Structural Stability Theory and Implementation. Prentice Hall. 1987
7. Hooley, R. F. and Madsen, B. Lateral Buckling of Glued Laminated Beams. Journal of Structural Engineering Division, ASCE, Vol. 90, No. ST3. June 1964.
8. Hooley, R. F. and Devall, R. H. Lateral Buckling of Simply Supported Glued Laminated Beams. University of British Columbia. 1965.
9. NDS Commentary. American Forest & Paper Association. 1997.
10. Flint, A. R. The Lateral Stability of Unrestrained Beams. Engineering, Vol 173, 1952, 65-67.
11. Nethercot, D. A. and Rockey, K. C. A unified approach to the elastic lateral buckling of beams. The Structural Engineer. Vol. 49, No. 7, July 1971, 321-330.
12. Salvadori, M. G. Lateral buckling of I-beams. ASCE Transaction Vol. 120, 1955, 1165-1177.

Appendix A

Derivation of Lateral-Torsional Buckling Equations

A.1 GENERAL

An unbraced beam loaded in the strong-axis is free to displace and rotate as shown in Figure A1. This displacement and rotation can be represented by three equations of equilibrium which equate the externally applied moment to the internal resisting moment:

1. moment in the strong-axis direction:
$$M_{ext} = -EI_x \frac{d^2v}{dz^2} \tag{A1}$$

2. moment in the weak-axis direction:
$$\beta M_{ext} = -EI_y \frac{d^2u}{dz^2} \tag{A2}$$

3. twisting moment:
$$\frac{du}{dz} M_{ext} = GJ \frac{d\beta}{dz} \tag{A3}$$

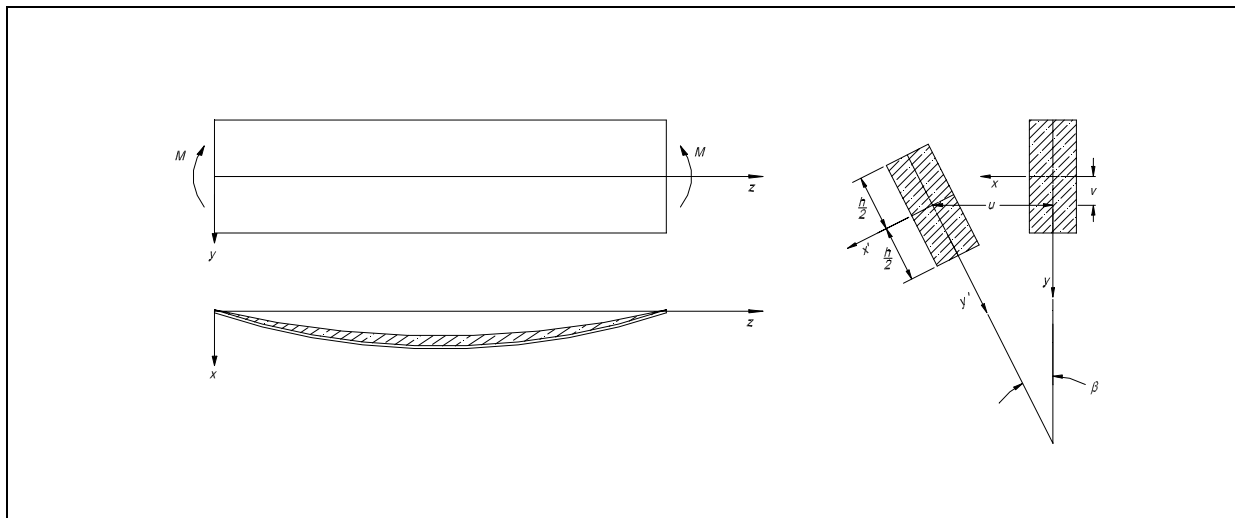

Figure A1. Lateral-Torsional Buckling of a Beam

Equation A1 describes the strong axis bending behavior of a beam and, for small displacements, is independent of Equations A2 and A3. Equations A2 and A3 are coupled. By differentiating Equation A3 with respect to z and substituting the result into Equation A2, the two equations can be combined to form the following second-order differential equation:

$$\frac{d^2\beta}{dz^2} + \frac{M_{ext}^2}{EI_y GJ} \beta = 0 \tag{A4}$$

A.1.1 CLOSED-FORM SOLUTION

If a beam has a constant cross-section and a constant induced moment, M_o , along the unbraced length, L , there is a closed-form solution to Equation A4. By defining a constant $k^2 = M_o^2 / EI_y GJ$, Equation A4 can be rewritten as:

$$\frac{d^2 \beta}{dz^2} + k^2 \beta = 0 \quad (\text{A5})$$

Equation A5 is a second-order linear differential equation with a general solution of:

$$\beta = A \sin kz + B \cos kz \quad (\text{A6})$$

Given that the rotation of the beam at the ends is prevented due to end restraint, these boundary conditions can be expressed as $\beta(0) = 0$ and $\beta(L) = 0$. Substituting the first condition into Equation A6, it can be seen that $B = 0$. Substituting the second condition into Equation A6 provides the following solution:

$$\beta = A \sin kL = 0 \quad (\text{A7})$$

To provide a nontrivial solution, A , can not equal zero. Therefore:

$$\begin{aligned} \sin kL &= 0 \\ kL &= \pi \end{aligned} \quad (\text{A8})$$

Substituting the value of k into Equation A8 and solving for the critical moment, M_{ocr} , yields:

$$M_{ocr} = \frac{\pi}{L} \sqrt{EI_y GJ} \quad (\text{A9})$$

A.1.2 INFINITE SERIES APPROXIMATION

If a beam has a constant cross-section but the induced moment, M , varies along the unbraced length, L , a closed-form solution does not exist and it must be solved by other means. One technique is to use an infinite series approximation. For example, consider a cantilevered beam with a concentrated load at the end of the beam. The induced bending moment, M , can be denoted as $M = P(L-z)$ where z is measured from the supported end. By defining a new value $x^2 = (L-z)^2$ and a constant $k^2 = P^2/EI_y GJ$, Equation A4 can be rewritten as:

$$\frac{d^2 \beta}{dx^2} + k^2 x^2 \beta = 0 \quad (\text{A10})$$

To solve the second-order differential equation in Equation A10, assume that the shape of the curve for β is a series of the form:

$$\beta = a_0 + a_1 x + a_2 x^2 + a_3 x^3 + \dots + a_n x^n + \dots \quad (\text{A11})$$

Differentiating Equation A11 twice, yields the following:

$$\frac{d^2 \beta}{dx^2} = 2a_2 + 6a_3 x + 12a_4 x^2 + 20a_5 x^3 + \dots + n(n-1)a_n x^{n-2} + \dots \quad (\text{A12})$$

Substituting Equations A11 and A12 into Equation A10 yields:

$$[2a_2 + 6a_3x + \dots n(n-1)a_n x^{n-2}] + [a_0 k^2 x^2 + a_1 k^2 x^3 + \dots a_n k^2 x^{n+2}] = 0 \quad \text{(A13)}$$

Combining like terms yields the following equation:

$$2a_2 + 6a_3x + [a_0 k^2 + 12a_4]x^2 + [a_1 k^2 + 20a_5]x^3 + \dots + [a_{n-4} k^2 + n(n-1)a_n]x^{n-2} = 0 \quad \text{(A14)}$$

It can be seen by inspection that Equation A14 can only be true if each term in the equation equals zero. Therefore, $a_2=0$, $a_3=0$, and for $n \geq 4$, $a_{n-4} k^2 + n(n-1)a_n=0$. Solving for a_n :

$$a_n = \frac{-a_{n-4} k^2}{n(n-1)} \quad \text{(A15)}$$

Substituting different values of n into Equation A15 yields the following set of equations to solve for each coefficient:

$n=4$	$a_4 = -a_0 k^2 / (3 \cdot 4)$	$n=8$	$a_8 = -a_4 k^2 / (7 \cdot 8) = a_0 k^4 / (3 \cdot 4 \cdot 7 \cdot 8)$
$n=5$	$a_5 = -a_1 k^2 / (4 \cdot 5)$	$n=9$	$a_9 = -a_5 k^2 / (8 \cdot 9) = a_1 k^4 / (4 \cdot 5 \cdot 8 \cdot 9)$
$n=6$	$a_6 = -a_2 k^2 / (5 \cdot 6) = 0$	$n=10$	$a_{10} = -a_6 k^2 / (9 \cdot 10) = 0$
$n=7$	$a_7 = -a_3 k^2 / (6 \cdot 7) = 0$	$n=11$	$a_{11} = -a_7 k^2 / (10 \cdot 11) = 0$

In general,

for $n=4, 8, 12, 16, 20, 24 \dots$	$a_n = a_0 (-k^2)^{n/4} / [3 \cdot 4 \cdot 7 \cdot 8 \cdot \dots \cdot (n-1) \cdot n]$
for $n=5, 9, 13, 17, 21, 25 \dots$	$a_n = a_1 (-k^2)^{(n-1)/4} / [4 \cdot 5 \cdot 8 \cdot 9 \cdot \dots \cdot (n-1) \cdot n]$
for $n=6, 10, 14, 18, 22, 26 \dots$	$a_n = 0$
for $n=7, 11, 15, 19, 23, 27 \dots$	$a_n = 0$

Substituting these coefficients into Equations A11 and A12 and simplifying yields the following equations:

$$\beta = a_0 \left(1 - \frac{k^2 x^4}{3 \cdot 4} + \frac{k^4 x^8}{3 \cdot 4 \cdot 7 \cdot 8} - \frac{k^6 x^{12}}{3 \cdot 4 \cdot 7 \cdot 8 \cdot 11 \cdot 12} + \dots \right) + a_1 \left(x - \frac{k^2 x^5}{4 \cdot 5} + \frac{k^4 x^9}{4 \cdot 5 \cdot 8 \cdot 9} - \frac{k^6 x^{13}}{4 \cdot 5 \cdot 8 \cdot 9 \cdot 12 \cdot 13} + \dots \right) \quad \text{(A16)}$$

$$\frac{d\beta}{dx} = a_0 \left(-\frac{k^2 x^3}{3} + \frac{k^4 x^7}{3 \cdot 4 \cdot 7} - \frac{k^6 x^{11}}{3 \cdot 4 \cdot 7 \cdot 8 \cdot 11} + \dots \right) + a_1 \left(1 - \frac{k^2 x^4}{4} + \frac{k^4 x^8}{4 \cdot 5 \cdot 8} - \frac{k^6 x^{12}}{4 \cdot 5 \cdot 8 \cdot 9 \cdot 12} + \dots \right) \quad \text{(A17)}$$

Given that there is no rotation of the beam at the fixed end and no change in rotation at the free end, the boundary conditions for this loading case can be expressed as follows:

$z = 0:$	$x = L:$	$\beta(L) = 0$
$z = L:$	$x = 0:$	$\frac{d\beta}{dx}(0) = 0$

Substituting the second condition into Equation A17, it can be seen that constant $a_1=0$. Substituting the first condition into equation A16, reduces it to the following:

$$\beta = a_o \left(1 - \frac{k^2 L^4}{3 \cdot 4} + \frac{k^4 L^8}{3 \cdot 4 \cdot 7 \cdot 8} - \frac{k^6 L^{12}}{3 \cdot 4 \cdot 7 \cdot 8 \cdot 11 \cdot 12} + \dots \right) = 0 \quad (\text{A18})$$

To provide a nontrivial solution a_o can't equal zero. Therefore, the minimum value of kL^2 where $\beta = 0$ occurs at $kL^2 = 4.013$. Substituting the value of k and solving for the critical value of P yields:

$$P_{cr} = \frac{4.013}{L^2} \sqrt{EI_y GJ} \quad (\text{A19})$$

Finally, by setting Equation A19 equal to the maximum moment equation for this loading condition ($M_{\max}=PL$) and simplifying yields:

$$M_{cr} = \frac{4.013}{L} \sqrt{EI_y GJ} \quad (\text{A20})$$

A.1.3 STRAIN ENERGY APPROXIMATION METHOD

Another technique used to approximate the critical buckling load of beams is the strain energy approximation method. When a beam buckles, the strain energy due to lateral deflection and twist is increased. The load which is applied to the beam is lowered, thereby decreasing the potential energy. The decrease in potential energy can then be set equal to the increase in strain energy. For example, take a simply-supported single span beam with a concentrated load at midspan. The increase in strain energy due to lateral deflection and twist can be denoted as follows:

$$\Delta U = EI_y \int_0^L \left(\frac{d^2 u}{dz^2} \right)^2 dz + GJ \int_0^L \left(\frac{d\beta}{dz} \right)^2 dz \quad (\text{A21})$$

The decrease in potential energy can be denoted as follows:

$$\Delta V = -P \int_0^L \beta \frac{d^2 u}{dz^2} \left(\frac{L}{2} - z \right) dz \quad (\text{A22})$$

Equating the increase in strain energy given in Equation A21 to the decrease in potential energy given in Equation A22 yields the following:

$$P \int_0^L \left[\beta \frac{d^2 u}{dz^2} \left(\frac{L}{2} - z \right) \right] dz = EI_y \int_0^L \left(\frac{d^2 u}{dz^2} \right)^2 dz + GJ \int_0^L \left(\frac{d\beta}{dz} \right)^2 dz \quad (\text{A23})$$

Using Equation A2, the following relationship can be defined for this loading condition: Substituting this value into Equation A23 and combining like terms yields:

$$\frac{d^2u}{dz^2} = \beta \frac{P}{2EI_y} \left(\frac{L}{2} - z \right) \quad (\text{A24})$$

Substituting this value into Equation A23 and combining like terms yields:

$$\frac{P^2}{4EI_y} \int_0^L \left[\beta^2 \left(\frac{L}{2} - z \right)^2 \right] dz = GJ \int_0^L \left(\frac{d\beta}{dz} \right)^2 dz \quad (\text{A25})$$

To estimate the critical value of P , a good approximation of the rotated shape along the length is needed. For a simply-supported single span beam, the shape can be approximated using a trigonometric series:

$$\beta = a_1 \cos \frac{\pi z}{L} + a_3 \cos \frac{3\pi z}{L} + a_5 \cos \frac{5\pi z}{L} + \dots \quad (\text{A26})$$

Substituting the first term of this approximation into Equation A25:

$$\frac{P^2}{4EI_y} \int_0^L \left[\left(a_1 \cos \frac{\pi z}{L} \right)^2 \left(\frac{L}{2} - z \right)^2 \right] dz = GJ \int_0^L \left(\frac{a_1 \pi}{L} \sin \frac{\pi z}{L} \right)^2 dz \quad (\text{A27})$$

Integrating both sides of the equation results in:

$$\frac{P^2}{4EI_y} \left(\frac{\pi^2 a_1^2 L^3}{294.6} \right) = GJ \left(\frac{\pi^2 a_1^2}{4L} \right) \quad (\text{A28})$$

Solving for the critical value of P yields:

$$P_{cr} = \frac{17.16}{L^2} \sqrt{EI_y GJ} \quad (\text{A29})$$

Finally, by setting Equation A29 equal to the maximum moment equation for this loading condition ($M_{\max} = PL/4$) and simplifying yields:

$$M_{cr} = \frac{4.29}{L} \sqrt{EI_y GJ} \quad (\text{A30})$$

Note: The actual constant in Equation A29 is 16.93 rather than 17.16; about a 1.5% error. This difference can be reduced to less than 0.1% by adding a second term to the approximation of β in Equation A27.

A.1.3 EQUIVALENT MOMENT FACTOR

The strain energy approximation method provides a tool for approximating the critical moment equation for many loading conditions. Using the previous example and the maximum moment equation for the previous loading condition ($M_{\max}=PL/4$), Equation A25 can be rewritten as:

$$\frac{M^2}{EI_y} \int_0^L \left[\beta^2 \left(1 - \frac{2z}{L} \right)^2 \right] dz = GJ \int_0^L \left(\frac{d\beta}{dz} \right)^2 dz \quad (\text{A31})$$

Developing a similar equation for the reference condition of a beam braced at both ends with a constant moment, Equation A25 can be rewritten as:

$$\frac{M_o^2}{EI_y} \int_0^L [\beta^2] dz = GJ \int_0^L \left(\frac{d\beta}{dz} \right)^2 dz \quad (\text{A32})$$

At this point an important assumption must be clearly understood. The rotated shape, β , is assumed to be approximately the same for all beams braced at both ends. Therefore, the second term in both Equations A31 and A32 are equal. Setting these equations equal and substituting the single term approximation for β (see Equation A26) yields:

$$\frac{M^2}{EI_y} \int_0^L \left[\left(a_1 \cos \frac{\pi z}{L} \right)^2 \left(1 - \frac{2z}{L} \right)^2 \right] dz = \frac{M_o^2}{EI_y} \int_0^L \left[\left(a_1 \cos \frac{\pi z}{L} \right)^2 \right] dz \quad (\text{A33})$$

Integrating both sides yields the following results:

$$\frac{M^2}{EI_y} (0.1340 a_1 L) = \frac{M_o^2}{EI_y} (0.2500 a_1 L) \quad (\text{A34})$$

Solving for the ratio, C_b , of the critical moment for the concentrated load case to the critical moment for the reference case yields:

$$C_b = \frac{M_{cr}}{M_{ocr}} = \sqrt{\frac{0.2500}{0.1340}} = 1.366 \quad (\text{A35})$$

Note: The actual moment ratio for these two loading conditions is 1.347 rather than 1.366; about a 1.5% error. This difference is due to the error associated with the assumed shape of β .

Equation A33 can be solved using any assumed shape of β . The accuracy of the assumed shape determines the error of the approximation. One commonly used shape of β is:

$$\beta = \frac{a_1}{2} \left(\frac{L^2}{4} - z^2 \right) \quad (\text{A36})$$

Substituting this value for β into Equation A33 yields:

$$\frac{M^2 a_1^2}{4EI_y} \int_b^L \left[\left(\frac{L^2}{4} - z^2 \right)^2 \left(1 - \frac{2z}{L} \right)^2 \right] dz = \frac{M_o^2 a_1^2}{4EI_y} \int_b^L \left[\left(\frac{L^2}{4} - z^2 \right)^2 \right] dz \quad (\text{A37})$$

Integrating both sides yields the following results:

$$\frac{M^2 a_1^2}{4EI_y} \left(\frac{29L^5}{3360} \right) = \frac{M_o^2 a_1^2}{4EI_y} \left(\frac{L^5}{60} \right) \quad (\text{A38})$$

Solving for the ratio, C_b , of the critical moment for the concentrated load case to the critical moment for the reference case yields:

$$C_b = \frac{M}{M_o} = \sqrt{\frac{3360}{1740}} = 1.390 \quad (\text{A39})$$

Note: For this load case, the moment ratio error is more than 3% as a result of the assumed shape of β .

It can be seen in the previous sections that the moment ratio, C_b , is a function of the area under the βM product curve. The familiar four-moment empirical equation was developed using this relationship. Formulation of the four-moment equation can be demonstrated using the previous load case of a concentrated load at midspan and the Equation A36 approximation of β . The rotated shape, β_i , and the moment, M_i , at each quarterpoint location for a concentrated load at midspan are:

$$\beta_A = \frac{3a_1 L^2}{64} \quad M_A = \frac{PL}{8} \quad \frac{M_A}{M_{\max}} = 0.50 \quad (\text{A40})$$

$$\beta_B = \frac{4a_1 L^2}{64} \quad M_B = \frac{PL}{4} \quad \frac{M_B}{M_{\max}} = 1.00 \quad (\text{A41})$$

$$\beta_C = \frac{3a_1 L^2}{64} \quad M_C = \frac{PL}{8} \quad \frac{M_C}{M_{\max}} = 0.50 \quad (\text{A42})$$

The values of β_i for the uniform moment load case are the same as those given in Equations A40-A42; however, the moment is constant ($M_A = M_B = M_C = M_o$). A constant, C , is used to calibrate the equation which relates the βM products for the two load cases as follows:

$$C_b = \frac{M}{M_o} = \frac{\beta_A + \beta_B + \beta_C + C}{\frac{\beta_A M_A}{M_{\max}} + \frac{\beta_B M_B}{M_{\max}} + \frac{\beta_C M_C}{M_{\max}} + C} = \frac{10 + C}{\frac{3M_A}{M_{\max}} + \frac{4M_B}{M_{\max}} + \frac{3M_C}{M_{\max}} + C} \quad (\text{A43})$$

The constant, C , used to calibrate Equation A43 varies with the loading condition. For the case of a concentrated load at midspan, the theoretical value of $C_b=1.347$ results in a constant $C=1.65$. For the load case of equal and opposite end moments (double curvature), $C_b=2.30$ resulting in a constant $C=2.4$. Conservatively, the value of C for use with the empirical method for determining the equivalent moment factor has been set at 2.5 resulting in the familiar equation:

$$C_b = \frac{12.5M_{\max}}{3M_A + 4M_B + 3M_C + 2.5M_{\max}} \quad (\text{A44})$$

This empirical procedure does not apply to beams braced at only one end, such as cantilevers.

A.2 LOAD ECCENTRICITY FACTOR

Equations derived in A.1 assume that loading is through the neutral axis of the member. In cases where the load is applied above the neutral axis at an unbraced location, an additional moment is induced due to the added displacement of the load at the top of the beam. The effect of this additional moment on the critical buckling moment can be estimated using the strain energy approximation method addressed in the previous section.

Using the example from the previous section, a concentrated load is applied at midspan of a simply-supported single span beam. The additional moment due to the load being applied at the top of the beam lowers the load point thereby decreasing the potential energy. The vertical distance, b , that the load is lowered can be denoted as follows:

$$b = \frac{h}{2}(1 - \cos \beta_o) \approx \frac{h\beta_o^2}{4} \quad (\text{A45})$$

The decrease in potential energy can be denoted as:

$$\Delta V = -\frac{Ph\beta_o^2}{4} \quad (\text{A46})$$

The location of the load is at midspan where $z = 0$. Using the previous definition of β , Equation A46 can be simplified to:

$$\Delta V = \frac{Ph}{4} \left(a_1 \cos \frac{\pi z}{L} \right)^2 = \frac{Pha_1^2}{4} \quad (\text{A47})$$

Adding the decrease in potential energy from the load applied at the top of the beam to Equation A27 yields:

$$\frac{Pha_1^2}{4} + \frac{P^2}{4EI_y} \int_0^L \left[\left(a_1 \cos \frac{\pi z}{L} \right)^2 \left(\frac{L}{2} - z \right)^2 \right] dz = GJ \int_0^L \left(\frac{a_1 \pi}{L} \sin \frac{\pi z}{L} \right)^2 dz \quad (\text{A48})$$

Integrating both sides of the equation results in:

$$\frac{Pha_1^2}{4} + \frac{P^2}{4EI_y} \left(\frac{\pi^2 a_1^2 L^3}{294.6} \right) = GJ \left(\frac{\pi^2 a_1^2}{4L} \right) \quad (\text{A49})$$

Equation A49 can be solved for the value P ; however, it can be seen that Equation A28 and Equation A49 have similar terms and it can be seen that, after some mathematical manipulation, they can be equated as follows:

$$\frac{GJ\left(\frac{\pi^2 a_1^2}{4L}\right)}{\frac{P_{na}^2}{4EI_y}} = \frac{GJ\left(\frac{\pi^2 a_1^2}{4L}\right) - \frac{P_{tp} h a_1^2}{4}}{\frac{P_{tp}^2}{4EI_y}} \quad (\text{A50})$$

Simplifying and solving for the critical load applied at the top of the beam, P_{tp} , results in:

$$P_{tp} = \sqrt{\left(\frac{P_{na}^2}{\pi^2} \frac{hL}{2GJ}\right)^2} + P_{na} - \frac{P_{na}^2}{\pi^2} \frac{hL}{2GJ} \quad (\text{A51})$$

Dividing Equation A51 through by P_{na} yields:

$$C_e = \frac{P_{tp}}{P_{na}} = \sqrt{\left(\frac{P_{na}}{\pi^2} \frac{hL}{2GJ}\right)^2} + 1 - \frac{P_{na}}{\pi^2} \frac{hL}{2GJ} \quad (\text{A52})$$

Terms in Equation A52 can be rearranged to:

$$C_e = \frac{P_{cr-tp}}{P_{cr-na}} = \sqrt{\eta^2 + 1} - \eta \quad (\text{A53})$$

where:

$$\eta = \frac{P_{na}}{\pi^2} \frac{hL}{2GJ} \quad (\text{A54})$$

Substituting the equation for P_{na} from Equation A29 into Equation A54 results in:

$$\eta = \frac{1.74h}{2L} \sqrt{\frac{EI_y}{GJ}} \quad (\text{A55})$$

Using the more accurate constant of 16.93 rather than 17.16 results in:

$$\eta = \frac{1.72h}{2L} \sqrt{\frac{EI_y}{GJ}} \quad (\text{A56})$$

Flint [10] demonstrated, numerically, that Equation A53 is accurate for cases where η lies between -0.34 and +1.72 (negative values indicate loads applied below the neutral axis and positive values indicate loads applied above the neutral axis). Limiting η to a maximum value of 1.72 would limit C_e to a minimum value of 0.27. For other loading conditions of a beam between supports, a similar procedure can be used to determine η . In general, Equation A56 can be rewritten as follows:

$$\eta = \frac{P_{na}}{\pi^2} \left(\frac{4\Delta V}{Pha_1^2} \right) \left(\frac{hL}{2GJ} \right) \quad (\text{A57})$$

To demonstrate the application of Equation A57, assume seven equally spaced loads along a beam braced at both ends. Using Equation A47, the effect of the multiple loads can be denoted as:

$$\Delta V = \frac{Pha_1^2}{4} (\cos^2 0.00\pi + 2\cos^2 0.125\pi + 2\cos^2 0.250\pi + 2\cos^2 0.375\pi) = \frac{4Pha_1^2}{4} \quad (\text{A58})$$

For loading through the neutral axis, the equation for calculating P_{cr} for this loading condition is:

$$P_{cr} = \frac{3.55}{L^2} \sqrt{EI_y GJ} \quad (\text{A59})$$

Substituting the value for ΔV and P_{cr} into Equation A57, the value of η for this loading condition can be estimated as:

$$\eta = \frac{1.44h}{2L} \sqrt{\frac{EI_y}{GJ}} \quad (\text{A60})$$

Appendix B

Derivation of 1997 NDS Beam Stability Provisions

Outlined in this Appendix is the process by which the “effective length” provisions contained in the 2001 and earlier versions of the *NDS* were developed by Hooley and Madsen [7]. Using Equation 1 adjusted for the loading condition of a concentrated load on a simply-supported beam:

$$M_{cr} = \frac{4.23C_e}{L_u} \sqrt{\frac{EI_y GJ}{\gamma}} \tag{B1}$$

For rectangular cross-sections, Hooley and Madsen assumed $G = E/16$; $J = 4I_y(1-0.63b/d)$; $\gamma = 1-(b/d)^2$ (see Appendix C.1 for explanation) and expanded Equation B1 to the following:

$$M_{cr} = \frac{2.12C_e EI_y}{L_u} \sqrt{\frac{1-0.63b/d}{1-(b/d)^2}} \tag{B2}$$

Recognizing that the term under the radical reaches a minimum value of 0.9425 when $b/d = 0.355$ (see Appendix C.1), Equation B2 was reduced to:

$$M_{cr} = \frac{2.0EI_y C_e}{L_u} \tag{B3}$$

Several approximation methods for determining the effect of load being applied at the top of the beam were reviewed. Hooley and Madsen used a study by Flint and, using Timoshenko’s first order energy approximation (corrected in a rederivation by Flint), derived simple “effective length” adjustments for the above mentioned load case.

$$C_e = 1 - \eta \quad \text{for} \quad -0.34 \geq \eta \geq 1.72 \tag{B4}$$

where:

$$\eta = \frac{1.733d}{2L_u} \sqrt{\frac{EI_y}{GJ\gamma}} \tag{B5}$$

Note: The estimated value of C_e in Equation B4 is only accurate in a limited range. Flint proposed a more accurate estimate of C_e using a quadratic solution (see Appendix A.2) which was not used by Hooley and Madsen. The more accurate quadratic solution is utilized in the procedures proposed in 1.2.3.1 and 2.1.3.4.

Hooley and Madsen used several approximations to simplify Timoshenko’s first order approximation of C_e . The steps are covered in the following equations:

$$C_e = 1 - 1.733 \left[\frac{\frac{d}{2L_u}}{\sqrt{\frac{1}{4} \left(1 - 0.63 \frac{b}{d} \right) \left(1 - \left(\frac{b}{d} \right)^2 \right)}} \right] \approx 1 - 1.733 \frac{d}{L_u} \left(1 + \frac{2b}{3d} \right) \quad (\text{B6})$$

$$C_e = 1 - 1.733 \frac{d}{L_u} \left(1 + \frac{2b}{3d} \right) \approx \frac{1}{1 + 1.733 \frac{d}{L_u} \left(1 + \frac{2b}{3d} \right)} \quad (\text{B7})$$

$$C_e = \frac{1}{1 + 1.733 \frac{d}{L_u} \left(1 + \frac{2b}{3d} \right)} \approx \frac{1}{1 + \frac{3d}{1.19L_u}} \quad (\text{B8})$$

Hooley and Madsen combined Equations B3 and B8 to produce the final equation:

$$M_{cr} = \frac{2.4EI_y}{1.19L_u + 3d} \quad (\text{B9})$$

The equation was further simplified to a general form for other loading conditions using a term for effective length, L_e :

$$M_{cr} = \frac{2.4EI_y}{L_e} \quad (\text{B10})$$

For a concentrated load at midspan:

$$L_e = 1.19L_u + 3d \quad (\text{B11})$$

For design, Hooley and Madsen recommended that the unbraced length, L_u , be increased 15% to account for imperfect torsional restraint at the supports:

$$L_e = 1.37L_u + 3d \quad (\text{B12})$$

In 1977, Equations B10 and B12 were incorporated into the NDS. Additional effective length equations were also developed for common loading conditions. In 1986, the use of Equation B12 was limited to $1.80L_u$ which occurs where $L_u/d \leq 7$:

$$1.8L_u \leq L_e \leq 1.37L_u + 3d \quad (\text{B13})$$

For use in the NDS, Equation B10 was converted to a critical buckling design stress by dividing the equation by the strong-axis section modulus, S_x , and multiplying by a series of adjustment factors to adjust the tabulated average E values to allowable 5th percentile shear-free E values. The final equation took the form of:

$$F_{be} = \frac{K_{be}E'}{R_B^2} \quad (\text{B14})$$

where:

$$K_{be} = 0.745 - 1.225COV_E \quad (\text{B15})$$

and,

$$R_B = \sqrt{\frac{L_e d}{b^2}} \quad (\text{B16})$$

Appendix C

Derivation of Rectangular Beam Equations

Outlined in this Appendix are assumptions made and procedures used to develop the simplified beam stability equations for rectangular members.

C.1 CRITICAL BUCKLING MOMENT

The general equation for the critical buckling moment, M_{cr} , is as follows:

$$M_{cr} = \frac{\pi C_b C_e}{1.15 \ell_u} \sqrt{\frac{E'_{y05} I_y G'_{y05} J}{\gamma}} \tag{C1}$$

For wood members, the E/G ratio ranges from 2 to 32. In practice, a value of 16 has typically been used.

For rectangular cross-sections, the torsional shear constant, J , and the cross-section slenderness factor, γ , can be estimated as:

$$J = 4I_y \left(1 - 0.63 \left[\frac{b}{d} \right] + 0.052 \left[\frac{b}{d} \right]^5 \right) \tag{C2}$$

$$\gamma = 1 - \left[\frac{b}{d} \right]^2 \tag{C3}$$

Substituting these values into Equation C1, yields the following solution:

$$M_{cr} = \frac{\pi C_b C_e E'_{y05} I_y}{2.3 \ell_u} \sqrt{\frac{1 - 0.63 \left[\frac{b}{d} \right] + 0.052 \left[\frac{b}{d} \right]^5}{1 - \left[\frac{b}{d} \right]^2}} \tag{C4}$$

The term under the radical in Equation C4 reaches a minimum value of 0.943 when $b/d = 0.355$. This can be seen in the following graph:

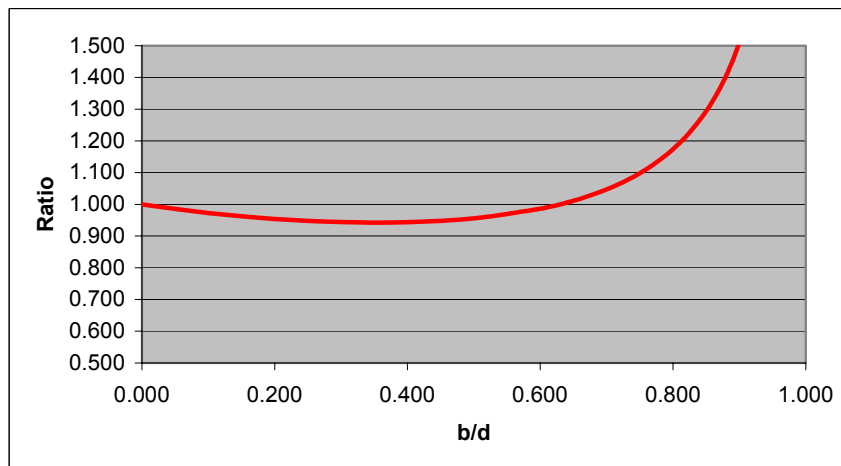

Substituting this minimum value into Equation C4 yields:

$$M_{cr} = \frac{1.3C_b C_e E'_{y05} I_y}{\ell_u} \quad (\text{C5})$$

C.2 LOAD ECCENTRICITY FACTOR FOR TOP-LOADED BEAMS

The general equation for the load eccentricity factor for top-loaded beams, C_e , is as follows:

$$C_e = \sqrt{\eta^2 + 1} - \eta \quad (\text{C6})$$

where:

$$\eta = \frac{kd}{2\ell_u} \sqrt{\frac{E'_{y05} I_y}{G'_{y05} J \gamma}} \quad (\text{C7})$$

Using the relationships assumed in the previous section for rectangular wood members, the η term can be simplified as follows:

$$\eta = \frac{kd}{\ell_u} \sqrt{\frac{1}{\left(1 - 0.63 \left[\frac{b}{d}\right] + 0.052 \left[\frac{b}{d}\right]^5\right) \left(1 - \left[\frac{b}{d}\right]^2\right)}} \quad (\text{C8})$$

The term under the radical in Equation C8 increases as the b/d ratio of the member increases and, therefore, reduces the critical load. This can be seen in the following graph:

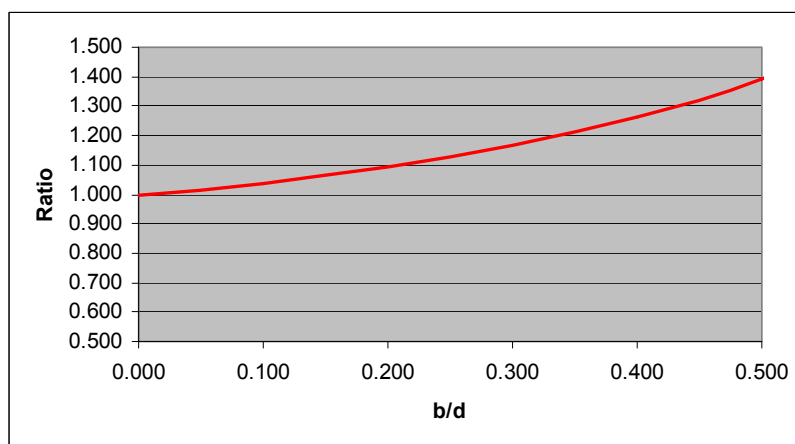

A maximum b/d ratio was chosen as 0.4286 representing the dimensions of a 2x4. For larger b/d ratios, this estimate is unconservative. However, the critical buckling moment for these cases is increasing at a rate that makes this adjustment insignificant. At $b/d=0.4286$, Equation C8 reduces to:

$$\eta = \frac{1.3kd}{\ell_u} \quad (\text{C9})$$

Appendix D

Graphical Representation of Wood Beam Stability Provisions (for beams loaded through the neutral axis)

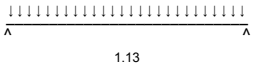
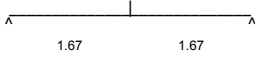
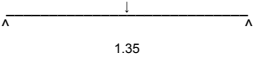
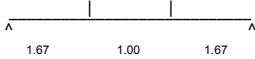
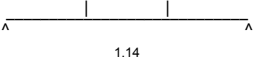
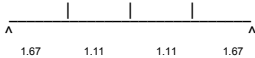
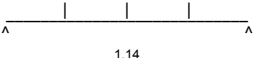
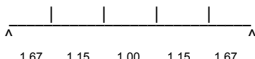
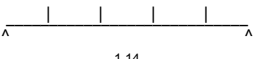
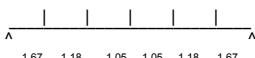
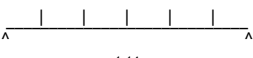
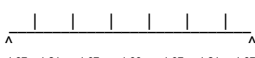
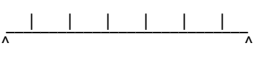
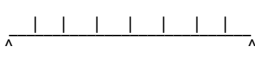
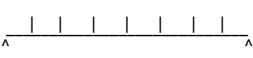
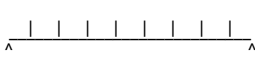
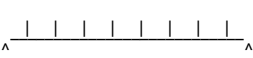
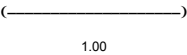
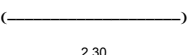
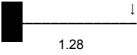
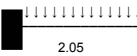
Loading Condition	Equivalent Moment Factor, C_b	
	Supported at Loading Point	Unsupported at Loading Point
Single Span Beams		
Uniformly distributed load		 1.13
Concentrated load @ center	 1.67	 1.35
Two equal conc. loads @ 1/3 points	 1.67 1.00 1.67	 1.14
Three equal conc. loads @ 1/4 points	 1.67 1.11 1.11 1.67	 1.14
Four equal conc. loads @ 1/5 points	 1.67 1.15 1.00 1.15 1.67	 1.14
Five equal conc. loads @ 1/6 points	 1.67 1.18 1.05 1.05 1.18 1.67	 1.14
Six equal conc. loads @ 1/7 points	 1.67 1.21 1.07 1.00 1.07 1.21 1.67	 1.13
Seven equal conc. loads @ 1/8 points	 1.67 1.20 1.09 1.03 1.03 1.09 1.20 1.67	 1.13
Eight equal conc. loads @ 1/9 points	 1.67 1.21 1.10 1.04 1.00 1.04 1.10 1.21 1.67	 1.13
Equal end moments (opposite rotation)		 1.00
Equal end moments (same rotation)		 2.30
Cantilever Beams		
Concentrated load @ unsupported end		 1.28
Uniformly distributed load		 2.05

American Forest & Paper Association

American Wood Council
1111 19th Street, N.W., Suite 800
Washington, DC 20036
www.awc.org
awcinfo@afandpa.org

America's Forest & Paper People®
Improving Tomorrow's Environment Today®

A F & P A®

