

SOUTHWEST RESEARCH INSTITUTE®

8220 CULEBRA ROAD 78238-5166 • P.O. DRAWER 28510 78228-0510 • SAN ANTONIO, TEXAS, USA • (210) 684-5111 • WWW.SWRI.ORG

CHEMISTRY AND CHEMICAL ENGINEERING DIVISION

FIRE TECHNOLOGY DEPARTMENT
WWW.FIRE.SWRI.ORG
FAX (210) 522-3377



FIRE RESISTANCE PERFORMANCE EVALUATION OF A PENETRATION FIRESTOP SYSTEM TESTED IN ACCORDANCE WITH ASTM E814-13A, STANDARD TEST METHOD FOR FIRE TESTS OF PENETRATION FIRESTOP SYSTEMS

FINAL REPORT
Consisting of 18 Pages

SwRI® Project No. 01.21428.01.001a
Test Date: September 30, 2015
Report Date: October 22, 2015

Prepared for:

American Wood Council
222 Catocin Circle SE
Leesburg, VA 20175

Submitted by:

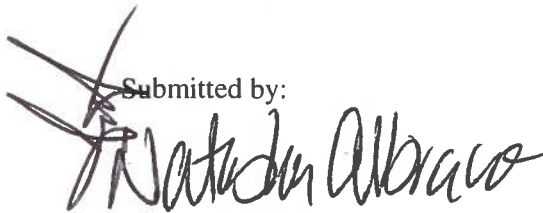
Natasha Albracht
Engineer
Fire Resistance Section

Approved by:

Karen C. Carpenter, M.S., P.E.
Manager
Fire Resistance Section

This report is for the information of the client. It may be used in its entirety for the purpose of securing product acceptance from duly constituted approval authorities. This report shall not be reproduced except in full, without the written approval of SwRI. Neither this report nor the name of the Institute shall be used in publicity or advertising.



Benefiting government, industry and the public through innovative science and technology

1.0 OBJECTIVE

The objective of the test described in this report was to evaluate the ability of multiple through-penetrations to provide a fire barrier. This test also evaluated the ability of the through-penetrations to maintain their structural integrity when subjected to a hose stream test following the fire exposure. Testing was conducted on September 30, 2015, at Southwest Research Institute's (SwRI) Fire Technology Department, located in San Antonio, Texas, for American Wood Council, located in Leesburg, Virginia.

2.0 TEST METHOD

The ASTM E814 test method is intended to evaluate the duration, for which a fire stop material, used to fill openings between building compartments, will contain a fire, or retain its structural integrity, or display both properties, during a predetermined fire exposure time. The test exposes a specimen to a standard fire controlled to achieve specified temperatures throughout a specified period. Two ratings, an F rating and a T rating, are assigned to a test specimen based on the performance during the fire test. The F rating is based on the specimen's ability to successfully provide a physical fire barrier for the desired rating period. The T rating is based on the specimen's ability to prevent thermal transmission (no thermocouple on the unexposed side of the specimen may increase 325 °F above its initial temperature). The fire exposure is followed by the application of a specified standard fire hose stream applied in accordance with ASTM E2226, under which, the specimen must prevent the passage of water to the unexposed side to successfully acquire either a T or F rating.

This standard is used to measure and describe the response of materials, products, or assemblies to heat and flame under controlled laboratory conditions, but does not by itself incorporate all factors required for fire hazard or fire risk assessment of the materials, products, or assemblies under actual fire conditions.

This report describes the test results obtained for three through-penetrations. The performance of the assembly is expressed in terms of the transmission of heat and hot gases during the standard fire exposure and penetration of water to the unexposed side of the assembly during the hose stream test. The results presented in this report apply specifically to the materials tested, in the manner tested, and not to the entire production of these or similar materials, nor to the performance when used in combination with other materials.

3.0 TEST ASSEMBLIES

Materials:	Provided By:	Received On:
• Two 1½-in. OD PVC	SwRI	
• ⅝-in. Type "X" gypsum wallboard	SwRI	
• Paper tape and joint compound complying with ASTM C 474 and C 475	SwRI	
• Mineral wool	SwRI	
• Fiber optical communication cable	SwRI	
• FS-One Max sealant	Hilti, Inc.	9/22/2015
• Two FS collar CP 643N 1-1/2 in.	Hilti, Inc.	9/22/2015
• One FS wrap strip CP 648-S 1-1/2 in.	Hilti, Inc.	9/22/2015

Sample Description

The sample tested was a 5-ply 6⅝-in. thick cross-laminated timber (CLT), covered with two layers of ⅝-in. type X gypsum board on the fire exposed side, with three different firestop through-penetrations installed. Figure 1 illustrates the layout of the installed penetrations.

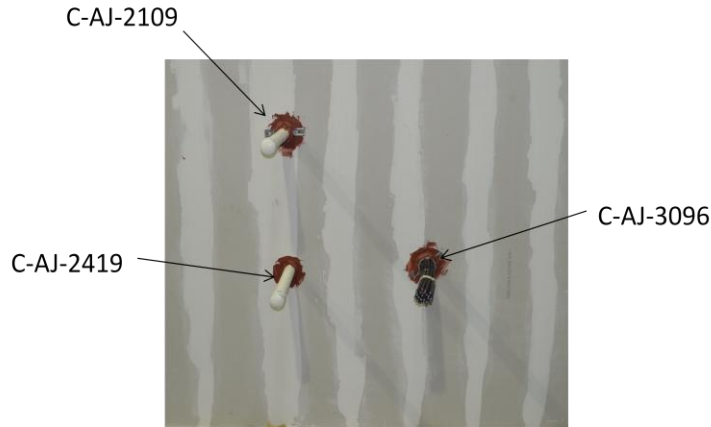

Figure 1. Through-Penetration Layout.

The following through-penetration firestop systems were evaluated in the test:

- Hilti C-AJ-2109 (modified as follows: 1.5-in. O.D. closed PVC pipe; no steel sleeve; 3.5-in. long wood screws used to attach the collar; pipe placed concentrically within hole; 2.5-in. sealant depth)
- Hilti C-AJ-2419 (modified as follows: 1.5-in. O.D. closed PVC pipe; 2-in. sealant depth.)
- Hilti C-AJ-3096 (modified as follows: no annular gap between the collar and the bundle of cables; no steel sleeve; 0.5-in. sealant depth was applied between the collar and gypsum board.)

Refer to Appendix C for Client-supplied drawings of these penetration details.

4.0 TEST RESULTS

Test Date:	September 30, 2015
Test Witness:	None
Ambient Temperature:	78.6 °F
Relative Humidity:	62.8%
Instrumentation:	The unexposed side of the sample was instrumented with 10 thermocouples (TCs) designed in accordance with ASTM E119. Each through-penetration had three TCs located on the firestop sealant, 1 in. onto the penetration material, and 1 in. onto the sample, and then a TC was placed in the center of all three penetrations. Refer to Figure B-2 for the TC layout. Three furnace temperature probes were used to control the temperature within the furnace during the test.
Hose Stream Test:	The hose steam test was conducted immediately after the 2-h exposure period. A nozzle designed in accordance with ASTM E814 and ASTM E226 was used, with a pressure of 30 psi and duration of 37.5 sec (based on a 5-ft ² exposure area). All penetrations successfully passed.
Rating Obtained:	All three through-penetrations achieved 2-h F and T ratings.
Results:	The acquired data is located in Appendix A in graphical form. Photographs taken before, during and after the test are located in Appendix B.
Deviations:	None

5.0 CONCLUSION

Based on the test results, all three through-penetrations achieved 2-h F and T ratings.

APPENDIX A
GRAPHICAL DATA
(CONSISTING OF 2 PAGES)

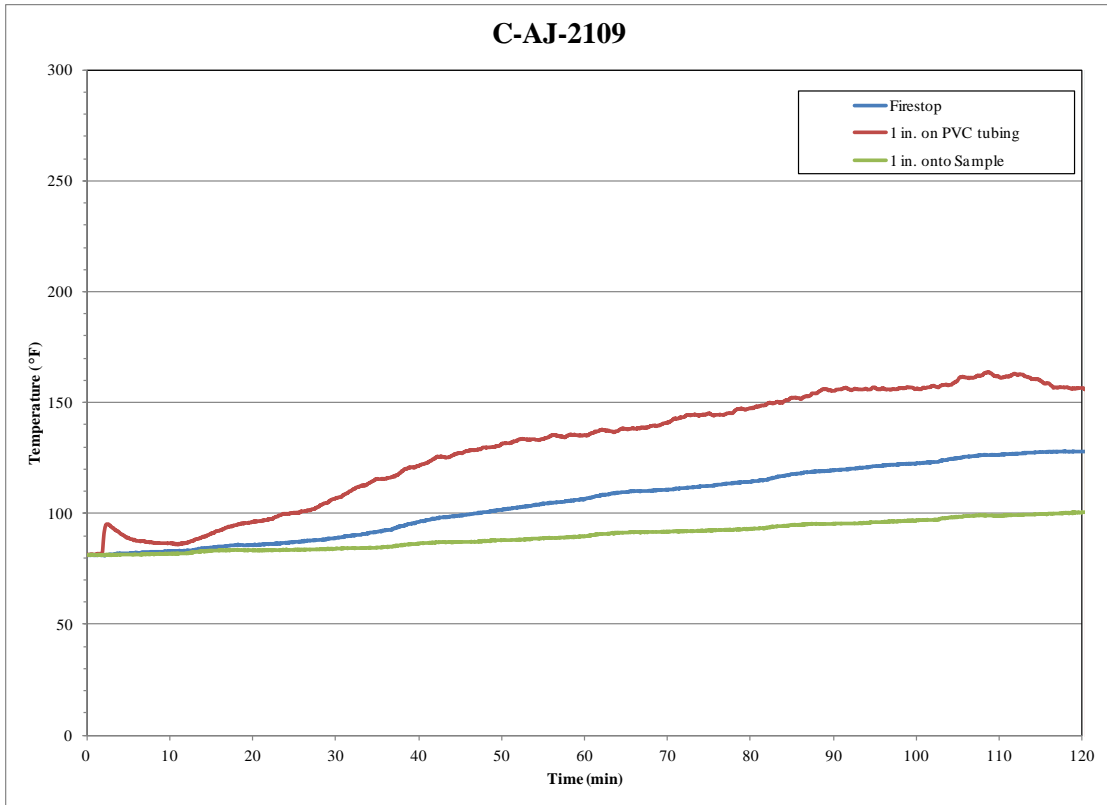

Figure A-1. Unexposed TC for Through-Penetration No. C-AJ-2109.

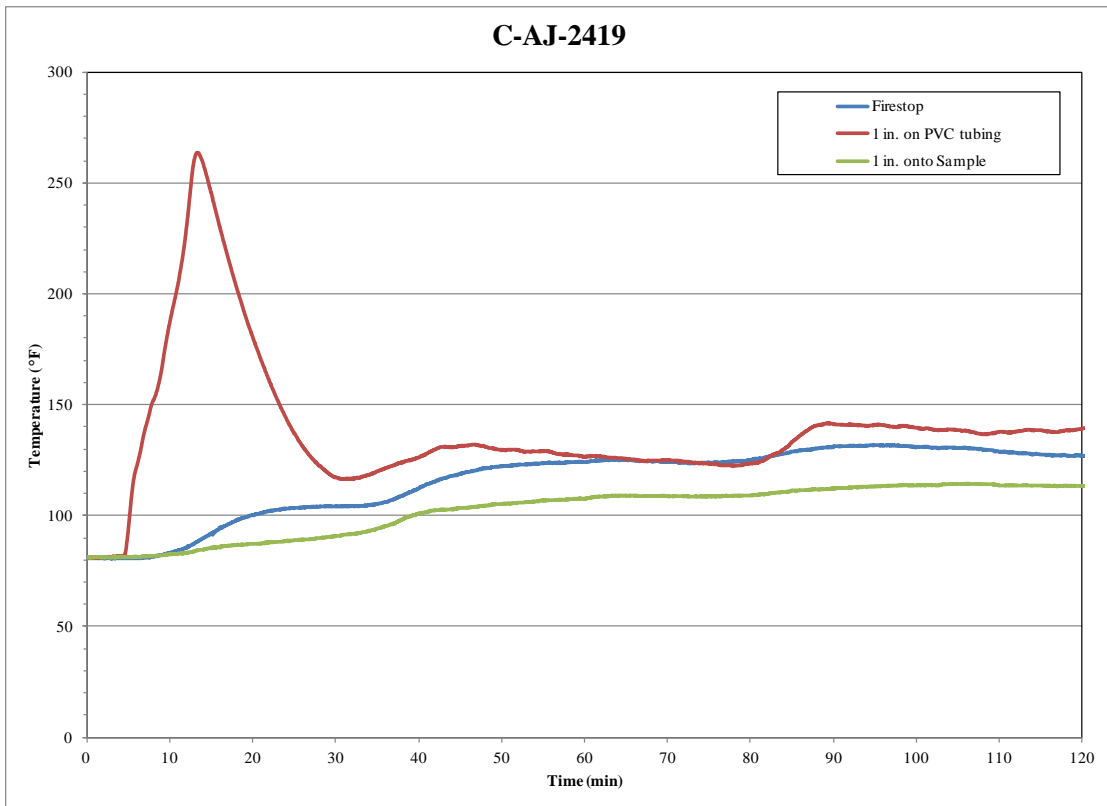

Figure A-2. Unexposed TCs for Through-Penetration No. C-AJ-2419.

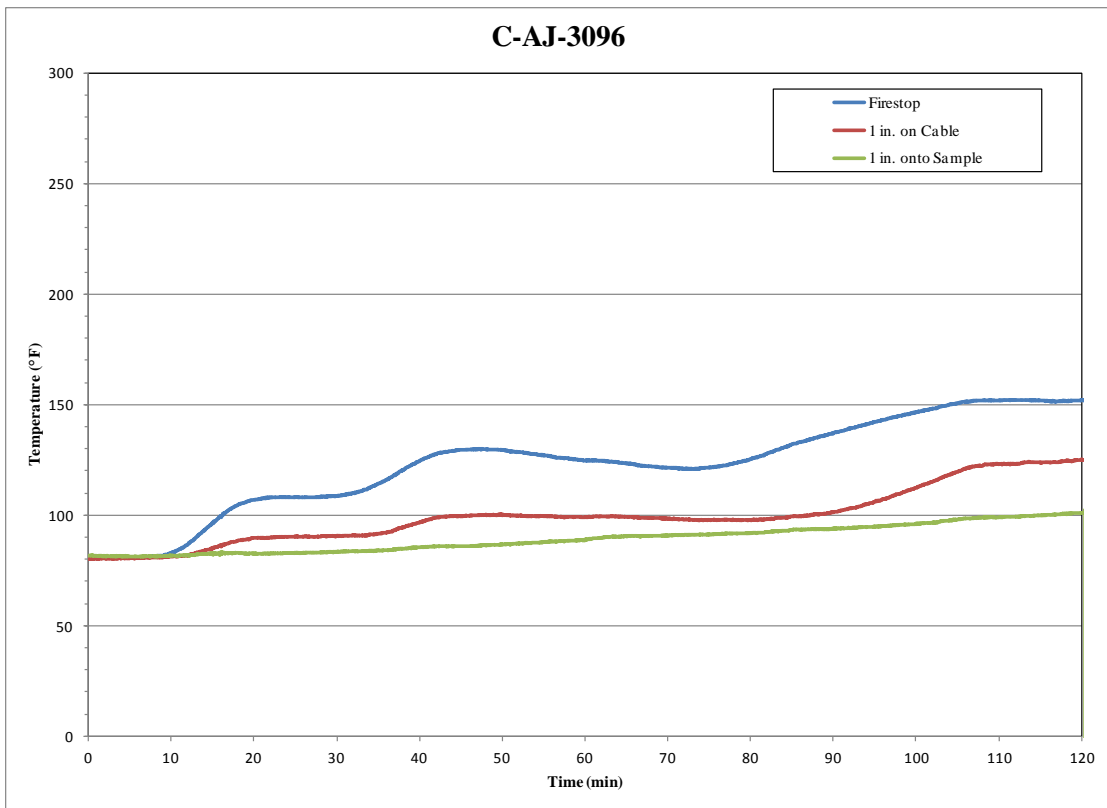

Figure A-3. Unexposed TCs for Through-Penetrations No. C-AJ-3096.

APPENDIX B
PHOTOGRAPHIC DOCUMENTATION
(CONSISTING OF 3 PAGES)



Figure B-1: Pretest Setup.

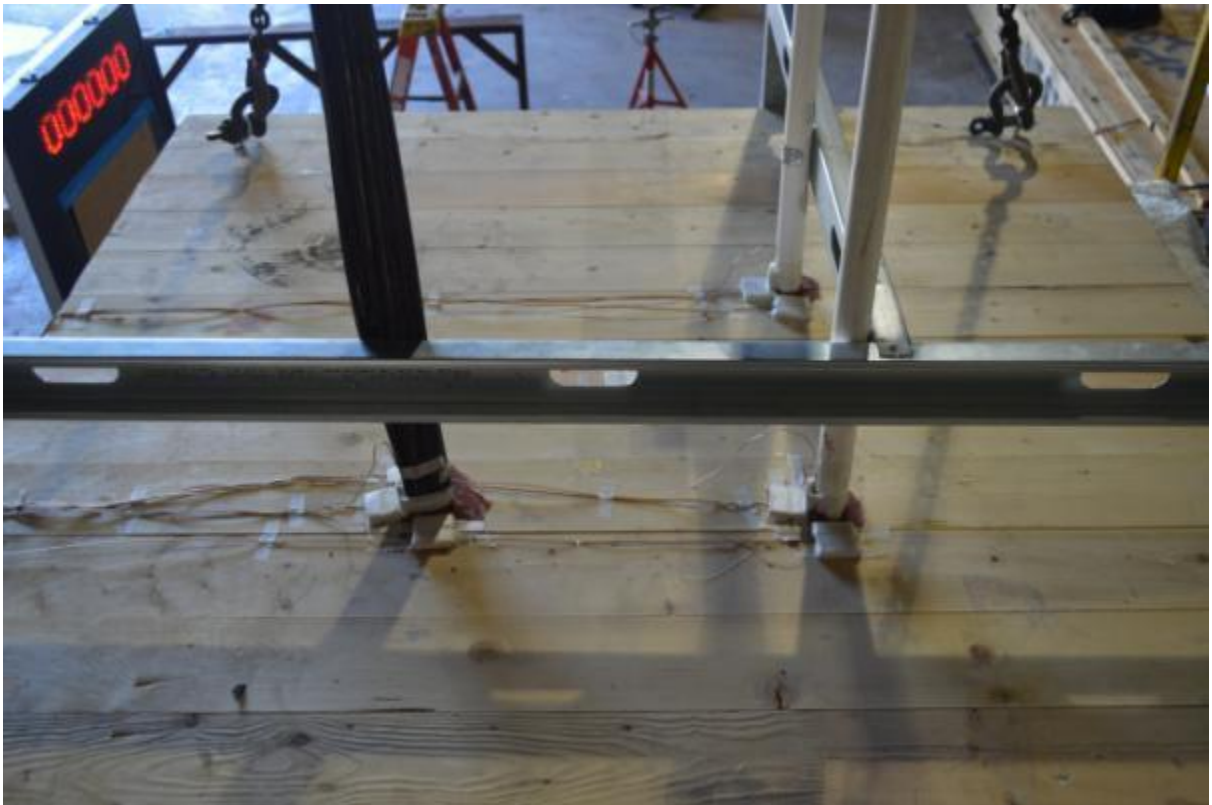

Figure B-2. TC Layout.



Figure B-3. Sample after 2-h Exposure.



Figure B-4. Sample before the Hose Stream Test.



Figure B-5. Sample after Hose Stream Test.

APPENDIX C
CLIENT-PROVIDED DRAWINGS
(CONSISTING OF 7 PAGES)

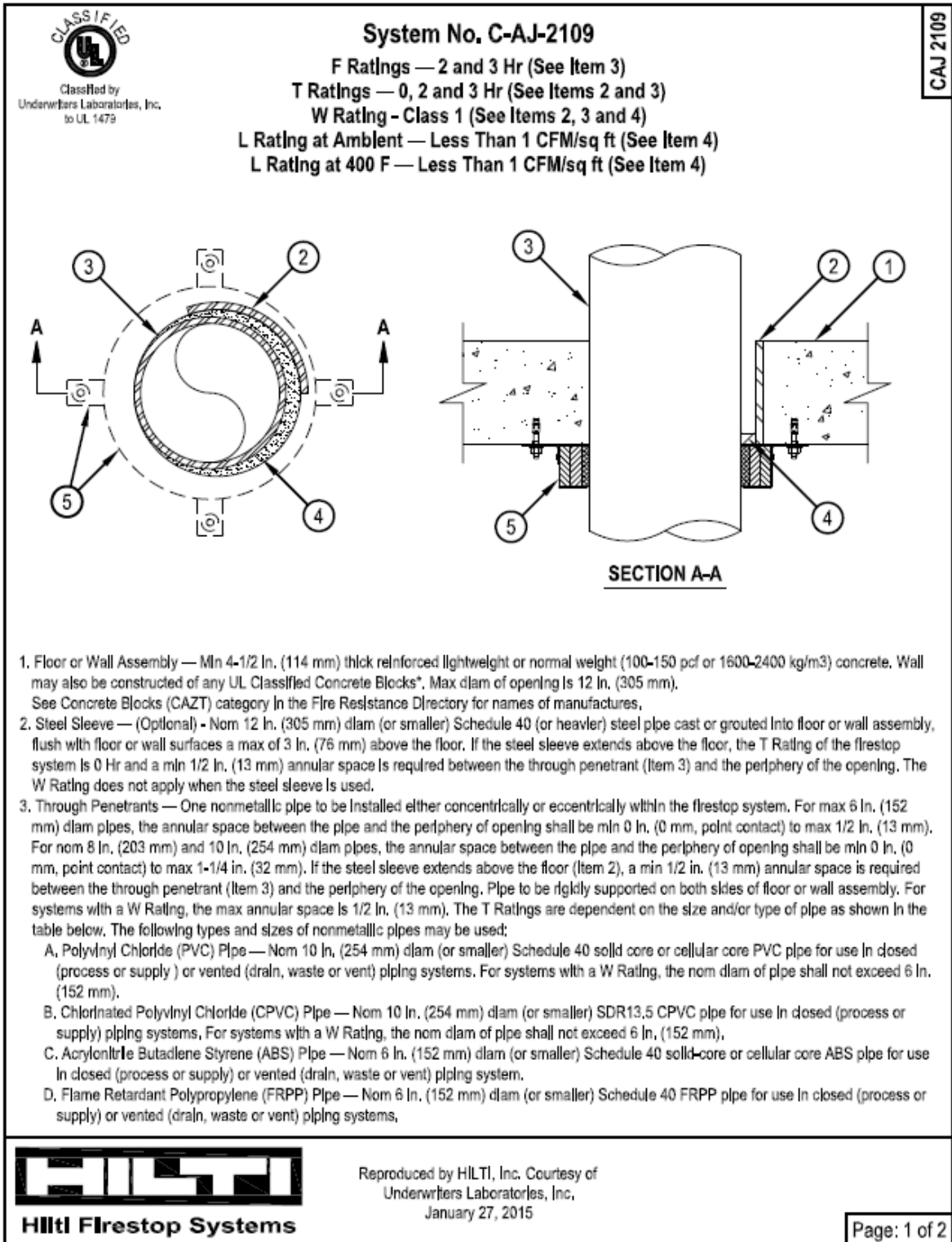

Figure C-1. Page 1 of Hilti, Inc. Through-Penetration Firestop System No. C-AJ-2109.

Pipe Type	Nom Pipe Diam, in. (mm)	F Rating Hr
PVC, CPVC	Greater than 6 (152)	2
PVC, CPVC, ABS, FRPP	6 (152) or smaller	3
Pipe Type	Nom Pipe Diam, in. (mm)	T Rating Hr
PVC, CPVC, ABS, FRPP	1-1/2, 2, 3 (38, 51, 76)	2
PVC, CPVC, ABS, FRPP	4 (102)	3
PVC, CPVC, ABS+, FRPP	6 (152)	3
PVC, CPVC	Greater than 6 (152)	0
ABS++	6 (152)	0

+ - Indicates solid core ABS only.

++ - Indicates cellular core ABS only.

4. Fill, Void or Cavity Material* — Sealant — Min 1/2 in. (13 mm) thickness of fill material applied within the annulus, flush with top or bottom surface of floor or both surfaces of wall. Sealant is optional for pipes having a max diam of 6 in. (152 mm) in unsleeved openings. For systems with W Rating and/or L Rating, min 1/2 in. (13 mm) thickness of CP 601S, CFS-S SIL GG, CFS-S SIL SL (floors only) or CP 604 Sealant shall be applied within the annulus, flush with top or bottom surface of floor.

HILTI CONSTRUCTION CHEMICALS, DIV OF HILTI INC — FS-ONE Sealant, FS-ONE MAX Intumescent Sealant, CP 601S Sealant, CFS-S SIL GG, CFS-S SIL SL (floors only) or CP 604 Sealant

4A. Packing Material (not shown) — Min 1/2 in. (13 mm) thickness of 4 pcf (64 kg/m³) mineral wool batt insulation firmly packed into annular space and recessed from the top surface of floor to accommodate the required thickness of fill material. Required only when CP 604 Sealant is used.

5. Firestop Device* — Firestop Collar — Firestop collar shall be installed in accordance with the accompanying installation instructions. Collar to be installed and latched around the pipe and secured to underside of floor or both sides of wall using the anchor hooks provided with the collar. Minimum two anchor hooks for nom 1-1/2 and 2 in. (38 and 51 mm) diam pipes. Minimum three anchor hooks required for nom 3 and 4 in. (76 and 102 mm) diam pipes. Minimum four anchor hooks required for nom 6 in. (152 mm) diam pipes. Minimum ten anchor hooks required for nom 8 in. (203 mm) diam pipes. Minimum twelve anchor hooks required for nom 10 in. (254 mm) diam pipes. The anchor hooks are to be secured with min 1/4 in. (6 mm) diam by min 1-1/4 in. (32 mm) long steel expansion bolts or min 0.145 in. (3.7 mm) diam by 1-1/4 in. (32 mm) long powder actuated fasteners utilizing a 1-7/16 in. (37 mm) diam by 1/16 in. (1.6 mm) thick steel washer. As alternates to the anchors specified above, Hilti 1/4 in. (6 mm) diam by 1-1/4 in. (32 mm) long KWIK-CON II+ concrete screw anchor, Hilti 1/4 in. (6 mm) diam by 1-3/4 in. (45 mm) long KWIK-BOLT 3 steel expansion anchor or Hilti X-DNI 27 P8 S15 powder actuated floor pin with integral nom 9/16 in. (15 mm) diam washer may be used. HILTI CONSTRUCTION CHEMICALS, DIV OF HILTI INC — CP 643N 50/1,5", CP 643N 63/2", CP 643N 90/3", CP 643N 110/4", CP 643 160/6", CP 644 200/8" or CP 644 250/10" Firestop Collar

* Indicates such products shall bear the UL or cUL Certification Mark for jurisdictions employing the UL or cUL Certification (such as Canada), respectively



Reproduced by HILTI, Inc. Courtesy of
Underwriters Laboratories, Inc.
January 27, 2015

Figure C-2. Page 2 of Hilti, Inc. Through-Penetration Firestop System No. C-AJ-2109.

System No. C-AJ-2419

F Rating - 3 Hr
T Rating - 0 Hr

CAJ 2419

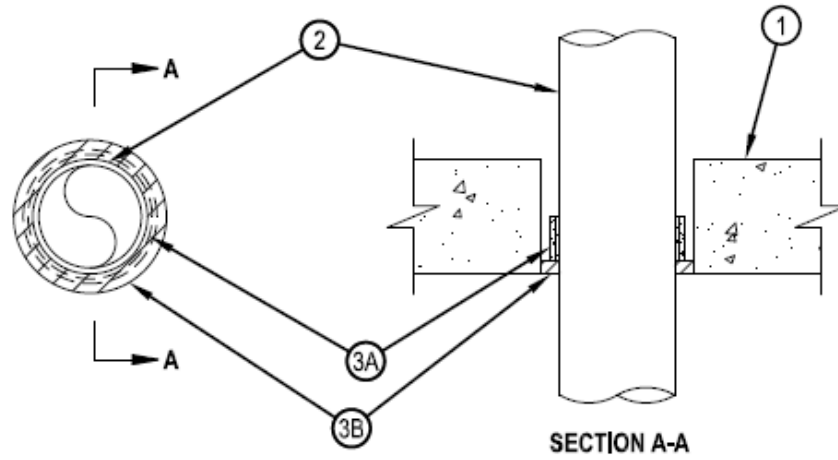

1. Floor or Wall Assembly — Min 4-1/2 in. (114 mm) thick reinforced lightweight or normal weight (100-150 pcf or 1600-2400 kg/m³) concrete floor or min 5 in. (127 mm) thick reinforced lightweight or normal weight (100-150 pcf or 1600-2400 kg/m³) concrete wall. Wall may also be constructed of any UL Classified Concrete Blocks*, Max diam of opening shall be 6 in. (152 mm). See Concrete Blocks (CAZT) category in the Fire Resistance Directory for names of manufacturers.
2. Through Penetrants — One nonmetallic penetrant centered within the firestop system. The annular space between pipe and periphery of opening shall be nom 3/4 in. (19 mm). Pipe to be rigidly supported on both sides of the floor assembly. The following types and sizes of non-metallic pipe may be used:
 - A. Polyvinyl Chloride (PVC) Pipe — Nom 4 in. (102 mm) diam (or smaller) Schedule 40 solid core or cellular core PVC pipe for use in closed (process or supply) or vented (drain, waste or vent) piping systems.
 - B. Chlorinated Polyvinyl Chloride (CPVC) Pipe — Nom 4 in. (102 mm) diam (or smaller) SDR 13.5 CPVC pipe for use in closed (process or supply) piping systems.
 - C. Acrylonitrile Butadiene Styrene (ABS) Pipe — Nom 4 in. (102 mm) diam (or smaller) Schedule 40 solid core or cellular core ABS pipe for use in closed (process or supply) or vented (drain, waste or vent) piping systems.
3. Firestop System — The details of the firestop system shall be as follows:
 - A. Fill, Void or Cavity Material* - Wrap Strip — Nom 3/16 in. (5 mm) thick by 1-3/4 in. (44 mm) wide Intumescent wrap strip. The wrap strip is continuously wrapped around the outer circumference of the pipe covering two times and slid into the annular space. When multiple wrap strips are used to achieve the required total length, the ends are to be butted end to end and held in place with tape. The bottom edge of the wrap strip shall be recessed 1/2 in. (13 mm) from the bottom surface of the concrete floor. In walls, the wrap shall be installed on both surfaces of the wall such that the exposed edge of the wrap strip is recessed 1/2 in. (13 mm) from each side of the wall. HILTI CONSTRUCTION CHEMICALS, DIV OF HILTI INC — CP 648-E- W45/1-3/4" Wrap Strip
 - B. Fill, Void or Cavity Materials* - Sealant — Min 1/2 in. (13 mm) thickness of fill material applied within the annulus, flush with bottom surface of floor or both surfaces of wall. HILTI CONSTRUCTION CHEMICALS, DIV OF HILTI INC — FS ONE Sealant or FS-ONE MAX Intumescent Sealant

* Indicates such products shall bear the UL or cUL Certification Mark for jurisdictions employing the UL or cUL Certification (such as Canada), respectively.



Reproduced by HILTI, Inc. Courtesy of
 Underwriters Laboratories, Inc.
 January 09, 2015

Figure C-3. Hilti, Inc. Through-Penetration Firestop System No. C-AJ-2419.

System No. C-AJ-3096

CAJ 3096

ANSI/UL1479 (ASTM E814)	CAN/ULC S115
F Rating — 3 Hr	F Rating — 3 Hr
T Ratings — 0, 1/2, 3/4, 1 and 1-1/2 Hr (See Item 3)	FT Ratings — 0, 1/2, 3/4, 1 and 1-1/2 Hr (See Item 3)
	FH Rating — 3 Hr
	FTH Ratings — 0, 1/2, 3/4, 1 and 1-1/2 Hr (See Item 3)

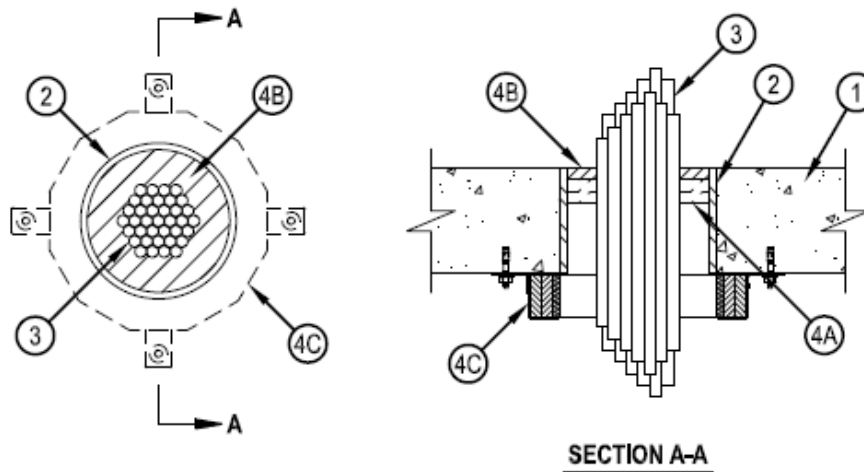

1. Floor or Wall Assembly — Min 4-1/2 in. (114 mm) thick reinforced lightweight or normal weight (100-150 pcf or 1600-2400 kg/m³) concrete floor or wall. Wall may also be constructed of any UL Classified Concrete Blocks*. Max diam of opening is 6 in. (152 mm).
 See Concrete Blocks (CAZT) category in the Fire Resistance Directory for names of manufacturers.
2. Steel Sleeve — (Optional) — Nom 6 in. (152 mm) diam (or smaller) Schedule 10 (or heavier) steel pipe cast or grouted into floor or wall assembly, flush with floor or wall surfaces.
3. Cables — Aggregate cross-sectional area of cables in opening to be min 25 percent to max 40 percent of the aggregate cross-sectional area of the opening. Cables to be rigidly supported on both sides of floor or wall assembly. Any combination of the following types and sizes of cable may be used:
 - A. Max 350 kcmil single conductor power cables with cross-linked polyethylene (XLPE) insulation. When single aluminum conductor power cable is used, T, FT and FTH Rating is 0 hr. When single copper conductor power cable is used, T, FT and FTH Rating is 1/2 hr.
 - B. Max 25 pair No. 24 AWG copper conductor telecommunication cables with polyvinyl chloride (PVC) insulation and jacket materials. When telecommunication cable is used, T, FT and FTH Rating is 3/4 hr.
 - C. Max No. 12 AWG multiconductor power and control cables with PVC or XLPE insulation and PVC jacket. When multiconductor power and control cable is used, T, FT and FTH Rating is 1 hr.
 - D. Multiple fiber optical communication cables jacketed with PVC and having a max outside diam of 1/2 in. (13 mm). When fiber optic cable is used, T, FT and FTH Rating is 1-1/2 hr.



Reproduced by HILTI, Inc. Courtesy of
 Underwriters Laboratories, Inc.
 January 13, 2015

Figure C-4. Page 1 of Hilti, Inc Through-Penetration Firestop System No. C-AJ-3096.



Classified by
Underwriters Laboratories, Inc.
to UL 1479 and CANULC-S115

System No. C-AJ-3096

CAJ 3096

4. Firestop System — The firestop system shall consist of the following:

A. Packing Material — Min 1 in. (25 mm) thickness of min 4.0 pcf (64 kg/m³) mineral wool batt insulation firmly packed into opening as a permanent form. Packing material to be recessed from top surface of floor or from both surfaces of wall as required to accommodate the required thickness of fill material.

B. Fill, Void or Cavity Material* (Optional) — Sealant — Min 1/2 in. (13 mm) thickness of fill material applied within the annulus, flush with top surface of floor or with both surfaces of wall.

HILTI CONSTRUCTION CHEMICALS, DIV OF HILTI INC — FS-One Sealant or FS-ONE MAX Intumescent Sealant

C. Firestop Device* — Firestop Collar — Firestop collar shall be installed in accordance with the accompanying installation instructions. Collar to be installed and latched around the cable bundle and secured to underside of floor or both sides of wall using the anchor hooks provided with the collar. (Minimum 2 anchor hooks for 1-1/2 and 2 in. (38 and 51 mm) diam pipes, 3 anchor hooks for 3 and 4 in. (76 and 102 mm) diam pipes, and 4 anchor hooks for 6 in. (152 mm) diam pipes). The anchor hooks are to be secured with 1/4 in. (6 mm) diam by min 1-1/2 in. (38 mm) long steel expansion bolts, in conjunction with steel nuts and min 3/4 in. (19 mm) diam steel washers with one anchor bolt in each anchor hook.

HILTI CONSTRUCTION CHEMICALS, DIV OF HILTI INC — CP 643 50/1.5"N, CP 643 63/2"N, CP 643 90/3"N, CP 643 110/4"N or CP 643 160/6"N Firestop Collar.

* Indicates such products shall bear the UL or cUL Certification Mark for jurisdictions employing the UL or cUL Certification (such as Canada), respectively.



Hilti Firestop Systems

Reproduced by HILTI, Inc. Courtesy of
Underwriters Laboratories, Inc.
January 13, 2015

Page: 2 of 2

Figure C-5: Page 2 of Hilti, Inc Through-Penetration Firestop System No. C-AJ-3096



AMERICAN
WOOD
COUNCIL
www.awc.org
info@awc.org

PROJECT NAME PENETRATION FIRESSTOP DETAIL #2

DATE 9/25/2015 PAGE# _____

(MODIFIED FROM C-AJ-2419)

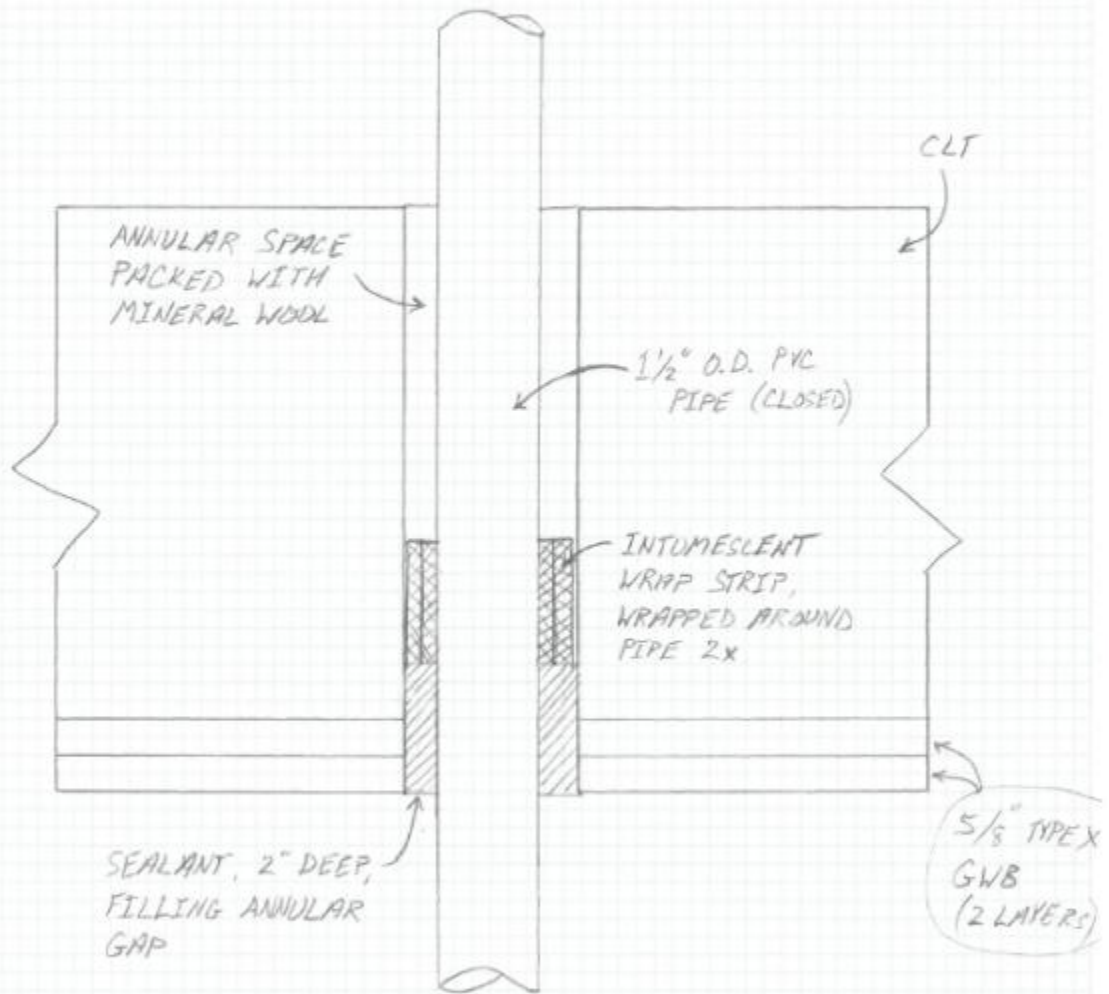

Figure C-6. Client-Provided Drawing of the Modifications for No. C-AJ-2419.



AMERICAN
WOOD
COUNCIL
www.awc.org
info@awc.org

PROJECT NAME PENETRATION FIRESTOP DETAIL #1

DATE 9/23/2015 PAGE# _____

(MODIFIED FROM C-AJ-2109)

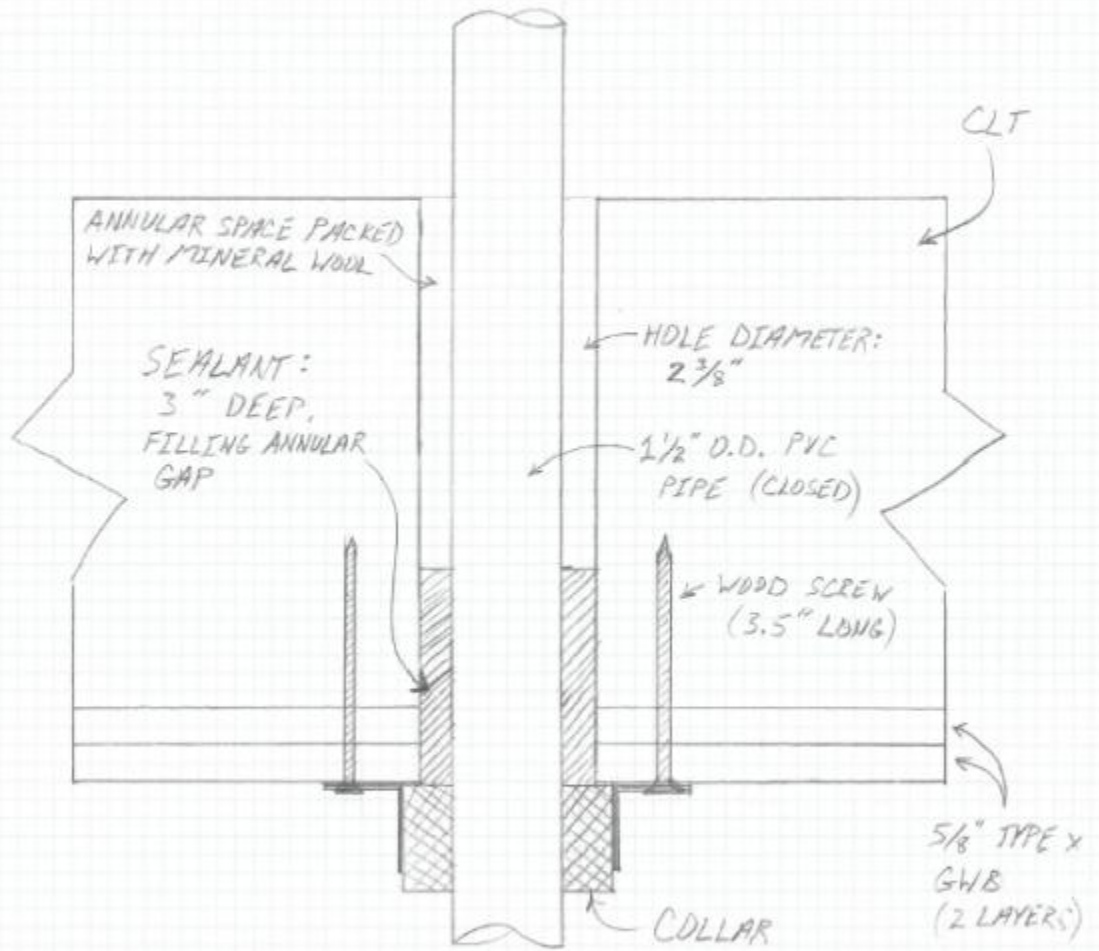

Figure C-7. Client-Provided Drawing of the Modifications for No. C-AJ-2109.